



Town of Erin

ENGINEERING DESIGN STANDARDS MANUAL



Document Control

File:

320859

Date:

**November
11, 2021**

Prepared by:

Tatham Engineering Limited
10 Diana Drive, Building 8, Unit 7
Orillia, Ontario L3V 8K8
T 705-325-1753
tathameng.com

Prepared for:

Town of Erin
5684 Trafalgar Road
Hillsburg, Ontario N0B 1Z0

| Authored by: | Reviewed by: |
|--|--|
| | |
| Brad Laking, B.A.Sc., P.Eng. Senior Engineer, Project Manager | Tim Collingwood, B.A.Sc., P.Eng. Director, Manager - Orillia Office |

| Disclaimer | Copyright |
|--|--|
| The information contained in this document is solely for the use of the Client identified on the cover sheet for the purpose for which it has been prepared and Tatham Engineering Limited undertakes no duty to or accepts any responsibility to any third party who may rely upon this document. | This document may not be used for any purpose other than that provided in the contract between the Owner/Client and the Engineer nor may any section or element of this document be removed, reproduced, electronically stored or transmitted in any form without the express written consent of Tatham Engineering Limited. |

| Issue | Date | Description |
|-------|--------------------|-----------------|
| 1 | July 22, 2021 | First Draft |
| 2 | September 28, 2021 | Appendices Only |
| 3 | November 11, 2021 | Second Draft |

Document Contents

Foreword..... viii

Revision Information Sheet.....x

1 General..... 1

1.1 Acknowledgement.....1

1.2 Definitions1

1.3 Abbreviations:.....2

1.4 Purpose and Background2

1.5 Intent and Objectives3

1.6 Engineer’s Role3

1.7 Town Roles and Responsibilities4

1.8 Town of Erin By-Laws.....4

1.9 Construction Act5

1.10 Barrier Free Considerations and Requirements.....5

2 Development Procedure..... 6

2.1 Plan of Subdivision Process.....6

2.2 Site Plan Process12

3 Engineering Design Criteria & Standards..... 16

3.1 Supporting Studies and Reports16

3.2 Drawings26

4 Water Supply System..... 38

5 Watermains..... 39

5.1 General.....39

5.2 Confirmation Of Available Capacity.....39

5.3 Service Area.....39



5.4 Design Flows.....39

5.5 Watermain Sizing.....41

5.6 Watermain Pressure42

5.7 Oversizing42

5.8 Watermain Layout42

5.9 Depth Of Cover.....43

5.10 Pipe Clearance43

5.11 Bedding And Backfill43

5.12 Restraining43

5.13 Deflection of Watermain44

5.14 Supporting of Watermain.....44

5.15 Termination of Watermain44

5.16 Fire Hydrants44

5.17 Valves.....45

5.18 Water Services.....46

5.19 Water Sampling46

5.20 Fire Department Connections46

5.21 Water Meters46

5.22 Tracer Wire47

5.23 Cathodic Protection.....47

5.24 Caution Tape.....47

5.25 Testing and Disinfection.....47

5.26 Materials.....49

6 Wastewater Pumping and Treatment..... 50

6.1 Communal Waste Disposal Systems.....50

6.2 Private Waste Disposal Systems50

6.3 Sewage Pump Stations.....50



6.4 Forcemains59

6.5 Emerging Technologies.....61

7 Sanitary Sewers..... 62

7.1 General.....62

7.2 Confirmation of Available Capacity62

7.3 Service Area.....62

7.4 Design Flows.....62

7.5 Pipe Capacity64

7.6 Velocities.....64

7.7 Pipe Slopes65

7.8 Minimum Pipe Size.....65

7.9 Depth Of Cover.....65

7.10 Bedding and Backfill.....65

7.11 Pipe Clearances65

7.12 Sewer Materials.....66

7.13 Sewer Layout66

7.14 Maintenance Holes.....66

7.15 Sanitary Service Connections.....68

7.16 Standard Easement Requirements.....69

7.17 Testing and Inspection69

8 Storm Drainage and Stormwater Management..... 71

8.1 Computer Modelling Guidance.....72

8.2 Service Area.....72

8.3 Design Flows.....73

8.4 Minor Drainage System79

8.5 Storm Sewer Design79

8.6 Major Drainage System.....86



8.7 Stormwater Management.....89

8.8 Low Impact Development89

8.9 Nutrient Management Strategy and Water Balance90

8.10 Stormwater Management Facilities90

8.11 Facilities Planting Guidelines.....98

8.12 Facilities Maintenance and Inspection Protocol103

8.13 Water Quality Treatment Units107

8.14 End-Of-Pipe Controls109

9 Roads118

9.1 Classification.....118

9.2 Pavement Design.....118

9.3 Geometric Elements119

9.4 Driveway and Entrance Design125

9.5 Walkways & Trails.....126

9.6 Signs and Pavement Markings129

9.7 Other Site Plan Considerations131

9.8 Scheduling of Work133

9.9 Maintenance.....133

9.10 Material Specifications.....134

9.11 Roadway Construction138

10 Lot Grading and Drainage142

10.1 General.....142

11 Utilities, Streetlighting, and Traffic Signals.....149

11.1 Utilities149

11.2 Streetlighting150

11.3 Traffic Signals155

12 Landscaping.....158



12.1 Tree Preservation.....158

12.2 Tree Inventory Requirements.....158

12.3 Tree Protection & Report158

12.4 Tree Preservation Measures159

12.5 Trenching and Tunneling.....160

12.6 Tree Compensation Requirements.....160

12.7 Landscape Requirements162

12.8 Topsoil & Seed Requirements162

12.9 Plant Material Considerations.....163

12.10 Acceptance and Warranty164

12.11 Design Considerations.....164

12.12 Acceptable Trees.....164

12.13 Mixture and Proportion of Species.....165

12.14 Tree Siting and Setback Requirements.....165

12.15 Landscape Strip Requirements - Residential Development166

12.16 Park and Playground Requirements167

12.17 Fencing171

13 Drawing Requirements.....173

13.1 Specifications for Engineering Drawings:.....173

13.2 General Drawing Requirements173

13.3 Computer Aided Drawings (CAD)174

13.4 General Servicing Plans174

13.5 Storm Drainage Plans175

13.6 Sanitary Drainage Plans.....175

13.7 Grading Plans.....176

13.8 Plan-Profile Drawings177

13.9 Composite Utility Plan.....178



13.10 Detail Drawings.....178

13.11 Parkland Development Drawings.....179

13.12 Landscaping.....179

13.13 As-Constructed Drawings180

Tables

Table 1: Population and Equivalent Population 40

Table 2: Consumption Rates..... 40

Table 3: Fire Flow Requirements 41

Table 4: Watermain Easement Standard Specifications 42

Table 5: Fire Hydrant Colour..... 49

Table 6: Population and Equivalent Population 63

Table 7: Generation Rates..... 64

Table 8: Maintenance Hole Spacing..... 67

Table 9: Maintenance Holes 67

Table 10: Sanitary Sewer Easement Standard Specifications 69

Table 11: Computer Model Recommendations..... 72

Table 12: Runoff Coefficient “C” 74

Table 13: IDF Equation Constants 76

Table 14: Manning’s Roughness Coefficients for Pipes 80

Table 15: Minimum Maintenance Hole Structure Drops..... 83

Table 16: Catchbasin Structure Spacing 84

Table 17: Maximum Allowable Flow Depths 87

Table 18: Stormwater Management Techniques..... 92

Table 19: End of Pipe Facilities..... 110

Table 20: Minimum Pavement Structure 118

Table 21: ESAL’s Corresponding to Pavement Structure..... 119

Table 22: Geometric Standards for Road Design..... 119

Table 23: Intersection Daylighting Requirements 121

Table 24: Illumination Summary 150

Table 25: Tree Compensation Ratios..... 161

Table 26: Tree Health Coefficient 161

Table 27: Topsoil Requirements 162

Table 28: Number of Trees and Species in Planting 165

Table 29: Landscape Strip Requirements..... 166



Appendices

Appendix A: Standard Drawings

Appendix B: Approved Seed Mix Designs

Appendix C: Acceptable Trees

Appendix D: Minimum Offsets for Streetlights

Appendix E: Cost Estimate Template

Foreword

This manual was prepared by Tatham Engineering Limited (Tatham), in collaboration with the Town of Erin (Town), under the direction of a Technical Working Group consisting of subject matter experts from the following Town departments/units:

| TOWN OF ERIN | JOB TITLE |
|--------------------------------------|-------------------------------------|
| Nick Colucci, P.Eng., BAsC, MBA, FEC | Director of Infrastructure Services |
| Khaled Rahman, P.Eng | Project Manager |
| | |
| | |
| | |
| | |

| TATHAM ENGINEERING LIMITED | JOB TITLE |
|----------------------------|--|
| Brad Laking, P.Eng. | Senior Engineer - Group Leader |
| Tim Collingwood, P.Eng. | Director, Manager Orillia Office - Quality Control |
| Wei Li, P.Eng. | Intermediate Engineer |
| Maureen Froese, E.I.T | Intern Engineer |

This manual was developed to reflect current and emerging standards and technology, legislation and best practices as they exist in 2021.

It should be recognized this manual cannot provide direction for all circumstances encountered. The Town reserves the right to apply discretion in the interpretation of this manual and require the use of other applicable guidelines and good engineering judgement when reviewing each project.

The design of all municipal services in the Town is to be based upon the specifications and standards in effect at the time of submission. It is incumbent upon the designer to ensure the

latest specifications are being utilized. All plans are to be accepted by the Town before they are used for the construction of municipal infrastructure; however, such acceptance in no way relieves the designer from providing an adequate and safe design. Current legislation shall always be followed.

Revision Information Sheet

The following table indicates all revisions including any additions, deletions and modifications to this manual subsequent to its issuance on **December XX 2021**. Revisions to these standards are subject to the approval of the Director of Infrastructure Services. A written request to change or revise the standards may be submitted to the Director of Engineering for review.

Revision details should include all related section titles, section numbers and page numbers.

Revision Summary

| REVISION NO. | DATE | REVISION DETAILS | INITIALS |
|--------------|------|------------------|----------|
| 1 | | | |
| 2 | | | |
| 3 | | | |
| 4 | | | |
| 5 | | | |
| 6 | | | |
| 7 | | | |
| 8 | | | |
| 9 | | | |
| 10 | | | |
| 11 | | | |
| 12 | | | |
| 13 | | | |
| 14 | | | |
| 15 | | | |

1 General

1.1 ACKNOWLEDGEMENT

The Town of Erin wishes to acknowledge the following municipalities for their contribution. Some information herein has been adopted from:

- City of Guelph
- Town of Halton Hills
- Town of Innisfil
- Township of New Tecumseth
- City of Orillia
- City of Vaughan

1.2 DEFINITIONS

In this document the following definitions shall apply:

Clerk shall mean Municipal Clerk of the Town.

Consultant shall mean a competent professional engineer or firm of engineers which is skilled and experienced in municipal work and land development projects and registered with the Association of Professional Engineers of the Province of Ontario, possessing a current Certificate of Authorization to practice professional engineering as required by the Professional Engineers Act.

Contractor shall mean the firm of Contractors, the company or individual acting as the Contractor and having entered into a contract with the Developer/Owner to install the services.

Developer(s)/Owner(s) shall mean the person(s) or company entering into the development agreement with the Town.

Standard Drawings shall mean drawings as developed and approved by the Town.

Town shall mean the Town of Erin.

Town Representative shall mean any person assigned to a project by the Town to carry out work on their behalf. The name of the Representative shall be specified prior to the start of construction on any project.

1.3 ABBREVIATIONS:

AWWA shall mean the American Water Works Association.

CHBDC shall mean the Canadian Highway Bridge Design Code.

CSA shall mean the Canadian Standards Association.

County shall mean the County of Wellington.

CVC shall mean Credit Valley Conservation

DFO shall mean the Department of Fisheries and Oceans, Canada.

ECA shall mean Environmental Compliance Approval.

GRCA shall mean the Grand River Conservation Authority.

NVCA shall mean the Nottawasaga Valley Conservation Authority.

MNRF shall mean the Ontario Ministry of Natural Resources and Forestry.

MECP shall mean the Ontario Ministry of the Environment, Conservation, and Parks.

MTO shall mean the Ontario Ministry of Transportation.

OBC shall mean the latest version of the Ontario Building Code including regulations.

CHBDC shall mean the Ontario Highway Bridge Design Code.

OPSD shall mean the Ontario Provincial Standard Drawings.

OPSS shall mean the Ontario Provincial Standard Specification.

1.4 PURPOSE AND BACKGROUND

To assist in the regulation of and provide guidance to private development, the Town of Erin (Town) prepared this Development Engineering Standards Manual (DESM). This DESM outlines the Town's current engineering requirements, guidelines, specifications, and standards that form the basis for obtaining engineering approvals related to the following development applications:

- Official Plan Amendments (OPA);
- Zoning By-Law Amendments (ZBA);
- Plan of Subdivision;
- Plan of Condominium;
- Site Plan;
- Part Lot Control;

- Consents (severances);
- Minor Variances; and
- Site Alteration Permits.

This DESM outlines specific requirements for Site Plan and Subdivision applications. Other application types listed above must also follow these requirements.

1.5 INTENT AND OBJECTIVES

This DESM is to be used by residents, Town staff, and development industry parties such as land developers, builders, consultants, and contractors. The intent of this DESM is to assist the development industry in preparing, and Town staff in processing, engineering submissions that form part of a complete development application.

The Town acknowledges that all developments are different and have their own unique challenges that can require professional judgment; therefore, this DESM should be viewed as the minimum requirements for the efficient design and approval of development engineering related works.

The key objectives of this DESM are to:

- Document process information related to the engineering submission of a development application;
- Outline requirements and standards for the engineering design of new developments within the Town;
- Provide guidance and framework for applicants submitting engineering designs and reports in support of development applications;
- Provide guidance to Town staff when reviewing and commenting on engineering aspects of a development application; and
- Identify the role and involvement of Town departments and external agencies as part of the development engineering review and approval process.

1.6 ENGINEER'S ROLE

The Developer shall appoint a qualified Consulting Engineer registered with the Association of Professional Engineers of Ontario, acceptable to the Municipality, to design, supervise and certify the construction and installation of the works.

The Developer acknowledges the Municipality is relying upon the skill and expertise of the Developer's Consulting Engineer in relation to the design and construction of the works including

the estimating of costs. As a result, no other engineer will replace the Consulting Engineer without the written approval of the Municipality. If other engineers are retained to assist in the design and construction of the works, such engineers will be duly qualified for the field related to the work undertaken.

1.7 TOWN ROLES AND RESPONSIBILITIES

The Town's Planning Department staff are responsible for the processing and recommendations/approval (where delegated) of a development application. The lead planner works with other Town departments, such as Infrastructure Services Department, to ensure the development application meets the requirements for all aspects of the planned development. The overall coordination of the development application file is the responsibility of the lead planner.

The Town's Infrastructure Services Department staff are responsible for reviewing and approving development engineering aspects of development applications, such as grading and drainage, servicing, stormwater management, noise study, traffic impacts, roads, environmental conditions, etc. Infrastructure Services Department also has the overall responsibility for maintaining and updating this document.

Additional approvals or permits for a development application may be necessary from External Agencies such as the Ministry of Transportation Ontario (MTO), the Ontario Ministry of the Environment, Conservation and Parks (MECP), the Grand River Conservation Authority (GRCA), the Credit Valley Conservation Authority (CVCA), County of Wellington, or other agencies. It is the applicant's sole responsibility to obtain any required external approvals/permits.

The Town may not be able to issue final approval for a development application prior to the applicant receiving required external agency approvals/permits. Information pertaining to the requirements for an external agency permit should be obtained directly from the external agency.

1.8 TOWN OF ERIN BY-LAWS

Prior to any work taking place on private or public property, the following By-laws (as amended) may apply:

- Municipal Sewer Use By-Law;
- Noise Control By-Law;
- Open Air Burning By-Law;
- Reduced Load Limit By-Law;
- Tree and Natural Vegetation Management Policy By-Law;

- Development Charge By-Laws (including Town wide and area specific);
- Community Safety Zone By-Law;
- Fees By-Law;
- Municipal Addressing By-Law;
- Noise By-Law;
- Park Use By-Law;
- Property Standards By-Law;
- Site Alteration By-law;
- Site Plan Control By-Law; and
- Zoning By-Law.

1.9 CONSTRUCTION ACT

Developers, Consultants, and Contractors shall comply with all provisions of the Construction Act and shall hold in its possession all statutory holdbacks and any additional funds required to be held by the Construction Act. These holdbacks and funds shall not be disbursed except in accordance with the Construction Act, and as stipulated in the development agreement.

1.10 BARRIER FREE CONSIDERATIONS AND REQUIREMENTS

All design projects throughout the Town must give due consideration to the Accessibility for Ontarians with Disabilities Act (AODA) and must incorporate ways to remove barriers for the public.

On Capital reconstruction projects where the requirements of AODA are not practical or financially feasible, exceptions may be accepted upon approval of the Director of Engineering providing there is sufficient justification outlining how the existing conditions prohibit proper application of the AODA standards.

2 Development Procedure

To assist in the regulation of private development, the Town of Erin has prepared this recommended development procedure which will act as a guideline in the development process. The procedure along with the requirements of the Official Plan, are to be incorporated in the review of all private developments. Applicants must meet with the Town Staff in advance of submitting a development application to discuss design standards to be used, availability of municipal piped water supply, environmental sensitivity of surrounding land uses and requirements of supporting information needed to assess the application.

A schematic of the development process is outlined in Figure 1. (<https://www.erin.ca/media/2175/erin-dev-process-poster.pdf>)

2.1 PLAN OF SUBDIVISION PROCESS

2.1.1 General

The Plan of Subdivision approval process is the primary instrument for regulating and providing the supply of residential, industrial and commercial lots and parcels in the Province of Ontario. Section 51(16) of The Planning Act, RSO 1990 c.P. 13 allows the owner of land or the owner's authorized agent to apply to the approval authority for approval of a Plan of Subdivision.

Town of Erin Council is the approval authority for Plans of Subdivision. The Town's planning department oversees the administration of subdivision approvals.

The Town's Infrastructure Services Department is involved in the engineering components of a Plan of Subdivision for the following aspects of the subdivision application:

- Draft Plan;
- Detailed Design;
- Construction; and
- Registration.

General information regarding each stage under the Town's current process is presented in Section 2.1.2 to 2.1.14. Detailed information for each step in the subdivision process can be obtained through discussions with the lead planner and engineering staff.

A schematic of the typical subdivision process is outlined in Figure 2 (<https://www.erin.ca/media/2811/draft-plan-of-subdivision-process.pdf>.)

2.1.2 Pre-Consultation and Application

As part of the Plan of Subdivision approval process, the applicant will participate in a pre-consultation meeting with the Town's planning department.

After the pre-consultation meeting, the applicant will be provided with a list of requirements for preparation of an application. The development engineering requirements will vary depending on the nature of the application.

2.1.3 Draft Plan of Subdivision

A Draft Plan of Subdivision application for a proposed development is submitted to the Town's planning department. Once the application package has been deemed complete, the lead planner will circulate it for review by the engineering staff assigned to the file, as well as to other Town departments.

The Draft Plan should show the proposed layout of development, meet planning requirements (e.g., conformity with the Planning Act, Official Plan, etc.), and provide engineering information such as:

- Sanitary, Stormwater and Water Servicing/Capacity;
- Stormwater Management;
- Grading concept;
- Road geometrics;
- External works (e.g., road improvements, sewer, etc.); and
- Noise and Traffic Impacts.

Upon completion of the engineering review of the Draft Plan of Subdivision (which may require resubmission by the applicant to address engineering Draft Plan comments), engineering may require a set of Draft Plan conditions be incorporated as part of the Draft Plan Approval. These conditions outline work that must be completed by the applicant prior to certain milestones being achieved for the development, such as conditions prior to grading/site alteration, or prior to execution of a subdivision agreement, etc.

2.1.4 Detailed Design

Once an application has received Draft Plan Approval (with the associated conditions), the applicant is required to prepare and submit detailed plans, reports, and designs. The required engineering design documents (reports, drawings, etc.) may include, but are not limited to:

- Stormwater Management Report/Stormwater Management & Servicing Report;

- Hydrogeology Report;
- Geotechnical Investigation Report and Slope Stability Assessment (as necessary);
- Traffic Impact Study (TIS);
- Detailed Noise Study;
- Environmental Impact Study (EIS);
- Environmental Site Assessment(s);
- Plan for Registration;
- Existing Condition and Removal Plan;
- General Servicing Plan;
- Storm Drainage Area Plan;
- Sanitary Drainage Area Plan;
- Plan and Profile of All Streets;
- Lot Grading and Drainage Plan;
- Stormwater and Sanitary Sewer Design Sheets;
- Stormwater Management Pond Grading and Details Plan;
- Geometric Road Design;
- Erosion and Sediment Control Plan;
- Detail Plans showing typical details and standards;
- On Street Parking Plan;
- Composite Utilities Plan;
- On Street Tree Planting Plan;
- Illumination / Photometric Plan
- Landscape plan; and
- Detailed cost estimates of all municipal services.

Depending on the nature of the proposed development, additional studies and plans may be required beyond those listed above. The Town may determine the need for any submitted plan or report to be peer-reviewed; any such cost shall be born by the applicant. All plans, drawings, and reports prepared for the detailed design should conform to the Town's Engineering Design Standards (see Sections 3-12).

2.1.5 Subdivision Agreement

Typically one of the engineering conditions of Draft Plan Approval is that the developer to enter into a Subdivision Agreement with the Town. The Subdivision Agreement contains such information as the developer's financial responsibilities, detail about easements and land conveyances to the Town, requirements for building permits and covenants to be registered on title. When the detailed design is acceptable to Town, and after receiving all regulatory agencies and authorities' approval, the Subdivision Agreement is prepared by Town. A draft of the Subdivision Agreement is circulated to other Departments and then the draft is sent to the developer for review. When the Subdivision Agreement is executed by the developer and the developer has provided the required financial security (see Section 2.1.6) as outlined in the Subdivision Agreement, the Town will execute the Subdivision Agreement. The Subdivision Agreement is then registered on title of the subdivision lands.

2.1.6 Financial Security and other Payments

The following is a list of typical Subdivision Agreement financial securities and other payments that are to be provided to the Town before the Subdivision Agreement is executed:

- 100% of the cost of the roads and servicing works;
- 100% of the cost of all works that are external to the plan of subdivision that are deemed to be the developers responsibility;
- Any outstanding taxes or local improvement charges on the property;
- Cash-in-lieu of parkland/parkland dedication;
- Street tree planting;
- Planning processing fee;
- Environmental fee(s); and
- Hard Services portion of the Development Charges for wastewater services, roads, storm drainage and waterworks.

2.1.7 Development Charges

Development Charges (DC) are fees collected from new development at the time a building permit is issued. The Town of Erin's current applicable Development Charges schedule to be used to calculate the amount of DCs that are required.

2.1.8 Construction, Maintenance Period, and Assumption of Municipal Services

Construction by the Developer, or a Contractor on their behalf, of all municipal services in accordance with the approved Subdivision Agreement, plans and specifications, and supervised by the Developer's Engineer. No operation of, connection to, or use of existing municipal services will be permitted without prior approval from the Town of Erin. The Developer shall submit all utility designs and layout to the Town of Erin for their review and approval before the installation of any utilities. Gas mains are to be provided on both sides of the street.

Submission to the Town of service testing reports and construction reports together with a request for preliminary acceptance of the services. Subject to any deficiencies being corrected by the Developer, the Town will grant Preliminary Acceptance of the services. Maintenance period starts following the preliminary acceptance. Developer maintains all of the municipal services and pays for all operating charges or cost until the date the services are assumed by the Town.

After correcting all deficiencies in the services at the end of the maintenance period to the Town's satisfaction, the developer can apply for Final Acceptance. The Town will not grant Final Acceptance for part of the services. Final Acceptance will only be granted by the Town when all the services to be constructed in accordance with the approved Subdivision Agreement have been completed.

The application for Final Acceptance shall include the Mylar Record Drawings and Certification from the Developer's Engineer and Ontario Land Surveyor.

2.1.9 Registration

Once the developer fulfills all of the conditions of Draft Plan approval, an application can be made to the Planning Department for registration of the Plan of Subdivision.

After registration, the lots, blocks and roads are created, and any parcels to be dedicated to the Town(e.g., parks, open spaces) are transferred, and easements in favour of the Town are conveyed. Registration of the plan of subdivision is required prior to application for a Building Permit (see Section 2.1.10).

2.1.10 Building Permits

The Subdivision or Site Plan Agreement outlines the requirements that are to be met before engineering staff can support the release of building permits. Typically, the requirements include such items as the Plan of Subdivision being registered, all easements and conveyances registered, the roads with base asphalt installed, the servicing works (including stormwater

management facilities) constructed and operational, the hydro servicing being complete and the erosion and sediment control measures being in place.

2.1.11 Model Home Permit

The Subdivision Agreement may contain provision for the developer to construct a model home. Typically, the requirements include such items as Plan of Subdivision being registered, all easements and conveyances registered and the erosion and sediment control measures are in place but the requirements do not typically require the roads, servicing and hydro to be complete. There would be no occupancy supported until the remaining building permit conditions are fulfilled. The Developer agrees to assume all risk involved in commencing the model home before every requirement for building permit has been met.

2.1.12 Foundation Permit

The Subdivision Agreement may contain provision for the developer to construct a foundation only (prior to receipt of a full building permit) at the developers risk.

Typically, the requirements include such items as the Plan of Subdivision being registered, all easements and conveyances registered and the erosion and sediment control measures are in place but the requirements do not typically require the roads, servicing and hydro installation to be complete. The construction of a structure above the foundation would not be supported until the remaining conditions are fulfilled for a full building permit.

2.1.13 Lot Release and Lot Grading Certification

The Subdivision Agreement will contain provision for the lots to be released from the registered Subdivision Agreement. Applications for lot release can be made to the Town after:

- All subdivision building permit conditions have been satisfied;
- The lot grading certificate has been submitted to the Town by the Developer's Engineer; and
- The lot has been completely sodded.

Notice to Purchasers clauses must remain registered on title.

The lot grading certificate can be prepared by a Professional Engineer or an Ontario Land Surveyor and must certify that the house and the lot grading conform to the overall approved subdivision lot grading and drainage plan.

2.1.14 Development Engineering Fee

Development engineering fee shall be calculated according to the Town's current tariff of fees for reviewing the applications.

2.2 SITE PLAN PROCESS

2.2.1 General

The Site Plan approval process is regulated by Section 41 of the Planning Act, R.S.O. 1990. The developer is required to submit plans and drawings (including the requirement of agreements) for development approval prior to the issuance of building permits.

The Town's Infrastructure Services Department is involved in the engineering aspects of the Site Plan review process, which include:

- Pre-Consultation and Application;
- Design Review; and
- Site Plan Approval.

General information regarding each stage under the Town's current process is presented in Section 2.2.2 to 2.2.7.

Other applications related to the Site Plan approval process may also be reviewed concurrently, including but not limited to Official Plan Amendment, Zoning Amendment.

2.2.2 Pre-Consultation and Application

An applicant is to complete a pre-consultation process with the Town prior to formally submitting a development application. As part of the Site Plan approval process, the applicant will participate in a pre-consultation meeting with the Town's staff.

After the pre-consultation meeting, the applicant will be provided with a list of requirements for preparation of an application. The development engineering requirements will vary depending on the nature of the application, but will typically include:

- Grading and Drainage Plan;
- Erosion and Sediment Control Plan;
- Site Servicing Plan;
- Existing Conditions and Removals Plan;
- Traffic Movement Plan (gas stations, drive-thrus, etc.);
- Site Plan;
- Details Plan;
- Functional Servicing Report;
- Stormwater Management Report;

- Traffic Impact Study;
- Cost estimates;
- Illumination / Photometric Plan;
- Landscape plan; and
- Environmental Site Assessment(s);
- Noise Study;
- Geotechnical Investigation Report and Slope Stability Assessment (as necessary); and
- Hydrogeological Assessment.

Depending on the complexity of the proposed development, additional studies and plans may be required beyond those listed above. The Town may determine the need for any submitted plan or report to be peer-reviewed; any such cost shall be born by the applicant. The engineering design criteria and standards that are to be used in preparation of the Site Plan Application are provided in Sections 3-12 of this Standard.

2.2.3 Engineering Design Review

Once an application is submitted and circulated by planning staff, the engineering staff responsible for the file will conduct a detailed review of the applicable engineering requirements and design aspects. The engineering staff will review the plans for conformance with Town standards, and will work with the applicant to ensure the plans are satisfactory. Depending on the application, there will typically be at least one re-submission of the plans so that the engineering requirements provided by engineering staff can be incorporated to the Town's satisfaction.

Engineering staff will coordinate the technical comments from specific engineering divisions (e.g., environmental, infrastructure, etc.), and other Town divisions, such as water, wastewater, operations, etc.

For work to be done within the Town's Right-of-Way (i.e., service connection laterals, curb cuts, boulevard work, sidewalk, etc.), the applicant's engineering consultant is required to estimate the cost to construct the works.

Engineering staff will also advise the developer of any costs for works that are external to the site but are deemed by the Town to be the developer's responsibility.

2.2.4 Site Plan Approval and Site Plan Control Agreement

Engineering final acceptance of the Site Plan will be granted once the estimated cost for right of way work is paid to the Town and all site plan comments have been addressed to the satisfaction of the Town. On a typical file, once Engineering final acceptance of the Site Plan is granted the applicant will be required to enter into a Site Plan Control Agreement to ensure that the work is carried out in accordance with any conditions that arise from the engineering review (Note: the agreement, which is written by Legal and Realty Services, is coordinated by the Town's planning department and also includes requirements from other departments).

2.2.5 Construction of Works Within the Town's Right-of Way

Construction by the Developer or a Contractor on their behalf, of all municipal services in accordance with the approved Site Plan Agreement, plans and specifications, and supervised by the Developer's Engineer. No operation of, connection to, or use of existing municipal services will be permitted without prior approval from the Town of Erin.

2.2.6 Building Permit

When a site is subject to Site Plan Approval, a building permit cannot be issued without first having either full Site Plan Approval or Conditional Site Plan Approval.

The timing for the different types of approval can vary based on the nature of the site plan application.

The Town can consider issuing Conditional Site Plan Approval for partial development of a site in stages. These approvals are offered as a way to allow construction to start ahead of final site plan approval in order to meet seasonal construction windows and other considerations. The applicant shall understand that they are taking full risk of starting the work without the guarantee of being granted final approval. Any changes required to the final design after the work has started, and any costs arising from such changes, will be borne solely by the applicant.

Site Plan Approval - When the Application is Part of a Subdivision

Presently, in a new subdivision, the Town does not grant Site Plan Approval until the associated Subdivision Agreement Conditions related to building permits have been fulfilled and the site plan meets the requirements of the Zoning By-Law, such as land use, parking, municipal services, etc. and Official Plan policies. Once the Subdivision Agreement Conditions are fulfilled and site plan is in compliance with the relevant policies and regulations, the Planning Department grants Conditional or Full Site Plan Approval and the Building Department can issue associated building permits, provided that all other Ontario Building Code related items are satisfied.

Site Plan Approval – When the Application is Not Part of a Subdivision

When a Site Plan application is for land that is not within a subdivision, engineering can either:

- Recommend Conditional Site Plan Approval (Foundation and Site Services) to planning staff once all engineering site plan items are acceptable; or
- Recommend Conditional Site Plan Approval (Foundation Only) to planning staff in advance of Site Plan acceptance for servicing design.

2.2.7 Development Engineering Fees

Development engineering fee shall be calculated according to the Town's current tariff of fees for reviewing the applications.

3 Engineering Design Criteria & Standards

These standards and specifications are intended as a guideline to provide a uniform engineering basis and consistent designs for all municipal and development projects within the Town of Erin. These standards are to be read in conjunction with the Town of Erin Engineering Design Standard Drawings as well as the Ontario Provincial Standard Specifications and Drawings (OPSS + OPSD). Where there are any apparent conflicts or discrepancies, the Town's Engineering Design Standards, Specifications, and Standard Drawings shall take precedence.

The information provided in this manual is general in nature and is not intended to relieve the Developer or the Engineer of their responsibility to submit a finished product of competent engineering design and construction. For any form of consideration made to deviate from Town standards, the Engineer shall submit a detailed proposal outlining the deviation, with the necessary justification and analysis, for consideration by the Town prior to formal engineering submissions.

If there are any preliminary concerns that are not addressed within this document, the designer is to coordinate a pre-consultation meeting with the Town's Engineering and/or Planning staff to resolve any issues prior to the commencement of the engineering design.

3.1 SUPPORTING STUDIES AND REPORTS

The following studies and reports may be required to support the design. It should be noted that the information provided is the minimum requirement and the studies and reports may need to include further details depending upon site-specific conditions. Additional reports or studies may be required at the discretion of the Town. The Engineering design shall incorporate the information and/or recommendations of the supporting studies and reports. A list of all reports or studies required to be submitted may include but is not limited to:

3.1.1 Functional Servicing Report (FSR)

The Functional Servicing Report (FSR) shall assess and describe the adequacy of the existing and proposed water distribution network, sanitary sewer servicing, storm sewer systems, and stormwater management features to satisfy the demands of the proposed development.

The FSR is intended to ensure that the proposed development can be serviced for the intended use, and that all onsite and off-site servicing requirements are clearly identified. The report shall include, as required:

- a) fire flow calculations;

- b) domestic demand;
- c) sanitary flows for allocation;
- d) plant capacity; and
- e) confirmation of pipe sizes.

The FSR shall incorporate all relative existing information including Town standards, reports, studies, record information in addition to site-specific and staging information. The Functional Servicing Report shall identify how the land will be serviced, focusing on the following:

- a) Geotechnical Investigation;
- b) Area and Site Grading;
- c) Transportation Network and Roadways;
- d) Water Distribution System;
- e) Sanitary Sewer System;
- f) Storm Drainage System Major / Minor;
- g) Utilities (Gas, Electrical, etc.);
- h) Public Open Space; and
- i) Sustainability.

3.1.2 Water Distribution System Analysis

A hydraulic network analysis and design report of the proposed water distribution system will be required with every new development, duly stamped and signed by a licensed professional engineer.

The Hazen-Williams equation shall be used for computing friction losses. Computer-based hydraulic network analysis programs shall be used where the proposed system is too complex for desktop methods of analysis. The network analysis using **WaterCAD** shall be conducted such that the model submitted is compatible for purposes of updating the Town-wide model.

Boundary conditions shall be determined through hydrant flow tests. Field confirmation of system performance using hydrant flow tests will be required prior to the release of building and/or occupancy permits. System operating conditions shall be recorded as part of the hydrant flow test.

The design report shall consist of the following elements, at a minimum:

- A clear list of all assumptions and modeling parameters (with specific reference to the Water Master Plan).
- Demand calculations.
- Hydrant flow test results and boundary condition assumptions.
- Schematic diagram of the system with fire flow locations, pipe information and ground elevations.
- Summary of results to include residual pressures and flow velocities for each scenario considered.
- Response Curves (i.e. plots or tables of Residual Head vs. Flow Rate) at critical hydrant locations, to be used as a basis for comparison after construction.
- Digital file of hydraulic model (if WaterCAD used for analysis).

Flow testing shall be completed as part of the underground certification as required to confirm adequate fire protection during building construction and prior to occupancy. Flow testing shall be completed again at Final Assumption to confirm that the flows conform to fire protection requirements.

3.1.3 Stormwater Management Report (SWM)

The Stormwater Management Report is to provide details and supporting calculations associated with the design of the minor and major drainage systems as well as the required source, conveyance, and end of pipe controls required to achieve the minimum standard targets established by this document as well as the Conservation Authority.

At a minimum, the following details must be included in the Report:

- a) Background Information;
- b) Stormwater Management Targets and Objectives;
- c) Review of Low Impact Development Practices and their Applicability;
- d) Pre-Development and Post-Development Drainage Areas;
- e) Storm Drainage System Design;
- f) Design of End of Pipe Controls;
- g) Erosion and Sediment Control;
- h) Inspection and Maintenance Requirements;
- i) Calculations, Tables, Figures, Modeling, and Drawings; and

j) Operations and Maintenance Manual.

3.1.4 Stormwater Management Operations and Maintenance Report

A stand-alone SWM facility operation and maintenance report shall be prepared for submission to the Town and the governing Conservation Authority for review. The following items shall be discussed in the Manual, where appropriate:

- i. Background information;
- ii. Stormwater management targets/ objectives and design criteria;
- iii. Storm drainage system design elements and general description of operation;
- iv. SWM facility design elements and general description of operation;
- v. Responsibility for maintenance activities;
- vi. Inspection and maintenance procedures;
- vii. Monitoring program and performance evaluation;
- viii. Removal and disposal of SWM facility sediments;
- ix. Estimated annualized operation and maintenance costs;
- x. Primary tables and supporting calculations; and
- xi. Primary figures and drawings.

3.1.5 /Geotechnical Report

The Geotechnical Report shall be prepared at the time of Draft Plan approval and must examine and confirm subsurface conditions including soil type(s) and stratification, groundwater levels, depth to bedrock, and soil bearing capacity. The report shall address minimum pavement structure and sub-drainage system.

The report shall assess the suitability of native soils for trench backfill and building foundation construction. It shall also address requirements for imported fill as well as construction methods for the use of both native and imported materials.

The report shall discuss the requirements for pipe bedding as well as engineered fill where necessary for building construction.

The report shall discuss removal and management of excess soil in accordance with O. Reg. 406/19, etc., as necessary.

The report shall be accompanied by a scaled drawing showing test pit and/or borehole locations complete with a detailed test pit and/or borehole log.

The report shall be signed and sealed by a qualified Professional Engineer or Professional Geoscientist licensed to practice in the Province of Ontario.

3.1.6 Hydrogeological Assessment

Hydrogeological studies for proposed projects must be conducted by a qualified Professional Engineer and/or Geoscientist to characterize the groundwater regime from a site-specific and regional perspective in order to address issues related to (as applicable):

- Impacts to existing well water supplies within the project area;
- Soil permeabilities and associated properties where the design of septic systems are concerned;
- Groundwater impact assessment to area aquifers from construction activities and/or discharge of waste or wastewater;
- Test wells and associated testing in accordance with Ministry of the Environment, Conservation and Parks (MECP) D-5-5 guidelines to address water taking impact sustainability;
- Impacts to nearby surface water bodies; and
- Specific technical review of well field or wellhead capture zones.

For general road and servicing construction, the report should consider the depth of services and identify likely areas where dewatering will be required, the rate of dewatering, requirements for dewatering, permits, and the strategy to achieve the required groundwater levels. If dewatering is necessary, the report should contain sufficient data on groundwater quality and temperature of the receiving watercourse. Where applicable, the report should also provide an assessment of the use of sump pumps for building design.

3.1.7 Traffic Impact Study

For developments expected to generate 100 or more vehicle trips during the peak hours (total of inbound and outbound trips), a Traffic Impact Study is required for review and approval by the Town. For developments that will generate less than 100 vehicle trips during the peak hours, a reduced scope study may be considered upon consultation with the Town.

A Traffic Impact Study should address the following:

Study Area

The study area should extend far enough, within reason, to contain all municipal and provincial roads that will be noticeably affected by the traffic volumes to be generated by the proposed development. The study area is to be confirmed with the Town prior to commencing the

assessment. The Town reserves the right to establish the study area as may be deemed necessary.

A description of the existing transportation system in the study area, using a combination of maps and other documentation, should identify relevant information, such as:

- Existing parking areas, existing roads, number of lanes, on-street bike lanes, traffic signals, posted speed limits, and other important signage;
- The lane configurations and control of the key intersections/roundabouts to be considered in the study;
- The provision of on-street parking in the vicinity of the development site and the potential for this to impact key intersections being analyzed;
- Other traffic controls and transportation facilities; and
- Other features of interest such as designated trails, walkways, etc.

Horizon Years & Period of Analysis

The horizon years should coincide to the anticipated full build-out of the site, in addition to five (5) and ten (10) years beyond full build-out. Interim horizon years must also be considered as necessary for the staged implementation of the identified road system improvements. For large developments where five (5) and ten (10) year design horizon beyond full build-out is not feasible, the design horizon can begin at the period of anticipated initial occupancy but requires written approval from Town.

Typically, the weekday AM and PM peak hours of the adjacent street will constitute the peak hours to be addressed. However, in the case of commercial, entertainment, religious, institutional or sports facility use, the weekend peak hours may be more appropriate. During the initial consultation process with the Town, the Consultant should determine the selected peak periods for analysis.

Existing Traffic Volumes

Figures illustrating the existing traffic volumes and turning movements for the study area roads and intersections are required. Traffic volumes may be acquired from the Town, MTO, other transportation studies in the area, or through traffic counts. To ensure representation of existing conditions, traffic count data should be no more than three years old.

Future Road Network & Background Volumes

Future traffic volumes should be prepared for each horizon year, with consideration for annual growth rates to reflect general growth in traffic in addition to the growth specific to new development. General growth can be estimated based on historic growth in area traffic volumes,

and/or future projections of area population and employment. Consideration can also be given to other area transportation studies and/or traffic models as appropriate.

All significant developments under construction, approved or in the approval process and that are likely to contribute additional traffic volumes within the horizon period, should be identified. The trips that are expected to be generated by these developments should be included in the future background volumes (trips can be established from a corresponding Traffic Impact Study or based on the land uses and published trip generation rates). Town should be consulted to establish the approved/active development proposals within the study area.

Future transportation improvements to the study area road network that are currently being considered should be identified. These improvements should be described to a level of detail sufficient to assess their implications for travel to/from the development site. In each case, identify the status and anticipated date of implementation for consideration in the Future Background and Future Total traffic conditions.

Proposed Development

The Traffic Impact Study should provide a full description of the proposed development, including the following as applicable:

- Municipal address (if applicable);
- Existing and proposed land uses;
- Total development area and summary by use (e.g. type and number of residential units, commercial gross floor area, etc.);
- Anticipated tenants; and
- Planned phasing and build-out period.

A site plan, concept plan, or similar, is to be included in the Traffic Impact Study document. If the proposed development is to be constructed in phases, describe each phase and the proposed implementation timing for each.

Site Traffic - Trip Generation

Unless advised by the Town, trip generation estimates are to be based on the proposed land uses, size of development and trip generation data from:

- The ITE Trip Generation Manual (most recent edition);
- Trip generation surveys conducted at similar developments/proxy sites; or
- “First Principles” calculations of anticipated trips to/from the site.

Where appropriate, it may be justified to reduce the base trip generation estimates to account for pass-by trips, internal/shared trips (in the case of a multi-use development), travel demand management practices, and transit use. The resulting estimates are referred to as “new” vehicle trips. All trip generation assumptions employed in the calculation of the “new” vehicle trips should be supported and well documented.

Sensitivity analysis should be undertaken where trip generation parameters have the potential to vary considerably and most probable values cannot be readily identified (i.e. the exact tenant or use of commercial space is not known). A trip generation table should be provided in the report to summarize the land uses and sizes, with the corresponding trip generation rates and the resulting number of trips. For large developments that will be phased in over time, the table should identify each significant phase separately.

Site Traffic - Trip Distribution & Assignment

Trip distribution assumptions should be supported by one or more of the following:

- Transportation Tomorrow Survey (TTS) data;
- Origin-destination surveys;
- Comprehensive travel surveys; or
- Existing/anticipated travel patterns.

Engineering judgement should be utilized to determine the most applicable of the above methodologies for each particular application. It is advised that Town be contacted regarding the trip distribution assumptions for site traffic requirements.

Trip assignments should consider logical routings, available and projected road capacities, and travel times. Trip assignments may be estimated using a transportation demand model or “hand assignment” based on knowledge of the proposed/future road network in the study area. The trip assignment should also take into consideration varying assignments for passby trips, link-diverted trips and internal trips.

Future Total Traffic Volumes

Future total traffic volumes are to be presented, representing the culmination of the future background traffic volumes and the site generated traffic volumes for each horizon year.

Traffic Impacts

An evaluation of the key signalized and un-signalized intersections within the study area for all relevant peak periods for the existing and future planning horizons (both with and without the subject development traffic) is required, and summaries are to be provided in a tabular format (e.g. level of service, volume to capacity ratio and delay). The intersection capacity/operational

analysis should be completed using Synchro/Sim Traffic Simulation Software or the like. The objective should be to ensure that no new problem movements are created by the proposed development and that existing problem movements are not worsened to an unacceptable level with the addition of site generated traffic. Where intersections are closely located, queueing assessments should be included with respect to appropriate storage, queue encroachment, back to back left turns, etc.

Should operational issues result, means of mitigation and the operations with consideration for such, are to be presented (e.g. introduction of traffic signals, additional through lanes, turn lanes, etc.) Appropriate warrants for improvements and associated operational review worksheets should be appended to the report.

Site Access Assessment

The site access should be reviewed in consideration of the volume and type of vehicles to be generated by the site, and the proposed access location and configuration. Town standards are to be referenced as applicable. Access points should be evaluated in terms of capacity, safety and adequacy of queue storage capacity. Should operational issues result at the site access, means of mitigation and the operations with consideration for such, are to be presented (e.g. introduction of traffic signals, additional through lanes, turn lanes, etc.) Appropriate warrants for improvements and associated operational review worksheets should be appended to the report.

Sight Line Assessment

At each access point and at each intersection where a new road is proposed, the sight distance requirements should be determined based on appropriate standards (MTO or County), and the availability of sight distance determined from actual field measurements or from engineering plans.

Documentation

The structure and format of the Traffic Impact Study should follow the guidelines outlined in this document as applicable. This format will facilitate review, discussion, and communication. Relevant maps, graphs, tables and figures should be provided.

3.1.8 Environmental Impact Study (EIS)

The Environmental Impact Study shall be prepared by a qualified professional and will assess any potential impact of the proposed project upon the natural environment including, but not limited to, wetlands, woodlots, and natural habitats for threatened and/or endangered species. The report shall also characterize the impact and make recommendations for mitigation, if necessary.

3.1.9 Archaeological Report

The Archaeological Report shall assess any significant historical features on the site and recommend a mitigation plan if necessary. The study shall follow the Ontario Ministry of Culture guidelines for determining the archaeological potential of the area impacted by construction. As a minimum, the report shall follow the requirements of a Phase 1 Archaeological survey and proceed with Phase 2 and 3, if necessary.

3.1.10 Phase 1 Environmental Site Assessment

For any lands that are to be dedicated to or purchased by the Town, an Environmental Site Assessment may need to be completed.

If required, a Phase I ESA shall be undertaken by a “qualified person” as defined in O. Reg. 153/04 (or the latest revision thereof) and a report shall be completed in accordance with the requirements set out in the same regulation as well as the guidelines published by the Canadian Standards Association (CSA).

The report shall include, but not be limited to:

- Confirmation of Insurance coverage;
- Certification the person undertaking the assessment and completing the report is a “qualified person”;
- The “qualified person’s” opinion as to whether a Phase II ESA is warranted based on the findings of the Phase I ESA;
- If the “qualified person’s” opinion is that a Phase II ESA is not required, the report shall expressly include a statement that “in his/her opinion and based on the findings of the Phase I ESA, a Phase II ESA is not necessary”; and
- Confirmation the report may be relied upon by the Town in making the decision to accept ownership of the property.

3.1.11 Noise and Vibration Study

This report shall identify sources of environmental noise and vibration under ultimate conditions and recommend mitigating measures in accordance with MECP Guidelines. Warning clauses shall be included in the report. The report is to be stamped and signed by a licensed professional Engineer.

3.1.12 Cost Estimates

Estimates for the cost of engineering, landscape and streetlighting works are to be prepared by the consulting team for purposes of determining review fees and financial securities to be held by the Town. A summary sheet shall be submitted in the Town standard format, supported by detailed breakdown.

A template for cost estimates and securities is included in [Appendix E](#).

The estimate shall be submitted with the second submission.

3.1.13 Additional Reports

The Town may require additional reports and/or assessments for proposed developments depending on specific site condition.

3.2 DRAWINGS

The following drawings are to be prepared for each development application, as applicable:

3.2.1 Specifications for Engineering Drawings:

All plans are to be A1 size and shall bear the seal of the registered Professional Engineer responsible for the design. Digital software compatible with AutoCAD shall be used to prepare all drawings.

All preliminary submissions shall be hard copy bonded.

All final submission and "as-constructed" drawings shall be bonded hard copies and with digital CAD files.

3.2.2 General Drawing Requirements

All engineering drawings shall be prepared in metric and in a neat and legible fashion. The design information presented on these drawings shall be completed in ink.

All plans shall have a title block and a revisions block. All revisions to the plans shall be properly noted in the revisions block with the revision number and date revised.

The lot numbering and block identification on all engineering drawings shall be the same as shown on the Registered Plan for the area.

All elevations shown on the engineering drawings are to be of geodetic origin. A local benchmark note must appear in each drawing.

All plan and profile drawings are to be prepared so that each street can be filed separately. The street names shall be identified on the plan portion of the drawings.

When streets are of a length that requires more than one drawing, match lines are to be used with no overlapping of information.

The reference drawing numbers for all intersecting streets and match lines shall be shown on all plan and profile drawings.

A north arrow and key plan shall be included on all drawings.

All engineering drawings shall be stamped by a Professional Engineer. The Engineers stamp must be signed and dated.

Work on the drawings to be done neatly and legibly.

Existing information shall be shown light or background line weight. Proposed information shall be shown bold or foreground line weight.

In general, east-west streets shall have zero chainage at their westerly limit and north-south streets shall have their zero chainage at their southerly limits. Chainage on a plan-profile shall increase from left to right.

3.2.3 Cover Sheet

Showing subdivision name, application number, key plan showing the subdivision's location relative to nearby arterial roads, Developer's and Consultants' information, a drawing index, Submission No. and Town File No.

3.2.4 Draft M-Plan(s) and R-Plan(s)

Shall be the most up-to-date Draft M-Plan and R-Plan showing all redline revisions.

3.2.5 Draft Plan(s) of Subdivision

Shall be the most up-to-date Draft Plan of Subdivision showing all redline revisions.

3.2.6 General Notes Sheet(s)

The approved general notes of the Town ([refer to TNT SD 700-704](#)) without alteration, any other text based information not included on any other drawing and a list of design exceptions (i.e., cases where the Town's design criteria and standards are not strictly adhered to.)

3.2.7 Detail Drawings

The Town of Erin Standard Drawings and the latest revision of the Ontario Provincial Standard Drawings (OPSD) shall be utilized whenever applicable. These drawings shall be reproduced as part of the engineering drawings for the development and must be referred to by number on the affected drawings. Individual details shall be provided for all special features not covered by the

Town of Erin Standard Drawings or OPSD. Prior to use of the proposed detail, the Consulting Engineer must receive written approval for its use.

3.2.8 General Servicing Plans

A “General Plan of Services” drawing showing aboveground services and appurtenances shall be prepared for all developments at a maximum scale of 1:1000.

The reference Geodetic Benchmark and the Site Benchmarks to be used for construction shall be identified on the General Plan of Services.

A Key Plan shall be shown on all “General Plan of Services” drawings and the area covered by the drawing shall be clearly identified.

A drawing index shall be shown on all “General Plans of Services” to identify the Plan and Profile Drawing number for each street or easement shown.

All road allowances, lots, blocks, easements and reserves are to be shown and are to be identified in the same manner as shown on the Registered Plan.

All existing services, utilities and abutting properties are to be shown.

All services to be constructed are to be shown.

All sites for parks, schools, churches, commercial and industrial development must be shown.

If a subdivision encroaches on an existing floodplain, the approved fill line restrictions must be shown, as specified by the MNR and/or CVCA, GRCA.

General Plans shall indicate, but not be limited to the following:

- Roadways with curblines and street names;
- Water mains and appurtenances, with notes showing sizes;
- Maintenance holes with numbers;
- Sewers with notes showing sizes, and direction of flow;
- Signage
 - school
 - traffic control
 - future land use;
- Barricades;

- Fencing indicating height and type;
- Retaining walls;
- Catchbasins;
- Community mail boxes with number of units serviced;
- Hydro vaults, streetlights, sidewalks.

3.2.9 Sanitary Drainage Plan(s)

All tributary areas used for the determination of the design flows shall be shown on a plan at the scale of 1:1,000. The plan shall indicate the land use, area and population density or number of units. Each sanitary drainage area on the plan shall show an identification number along with population and area.

A separate External Sanitary Drainage Plan may be required to show large external areas. Scale 1:1000.

3.2.10 Storm Drainage Plan(s)

The plan shall be prepared to a scale of 1:1,000 or 1:2,000.

The storm drainage plan shall indicate but not be limited to the following:

- Existing contours at maximum 1.0 m intervals;
- Drainage patterns of adjacent lands;
- Run-off coefficients and areas (ha) of tributary areas outside the development and for each section of the storm sewers within the development;
- Direction of run-off;
- Street names;
- Maintenance hole numbers;
- Sewer sizes, slope and directions of flow;
- Any catchbasins or swales, on the lots or blocks, required to collect the run-off;
- Temporary or permanent quantity and quality storm water management facilities;
- Major and minor overland flow routes; and
- Culverts and other drainage appurtenances.

A separate *External Storm Drainage Plan* may be required to show large external areas. Scale 1:1000.

3.2.11 Sanitary & Storm Design Sheets(s)

Sanitary and Storm Design Sheets for the Development as outlined in this document.

3.2.12 Water Distribution System Plan(s)

Showing existing and proposed watermains, internal and external demand information, as well as any hydrant flow test or static pressure test results including the test dates and times and fire flow table. Scale 1:1000.

3.2.13 Grading Control Plan(s)

Grading plans shall be a minimum scale of 1:500.

The grading plans shall indicate, but not be limited to the following:

- All lots and blocks within the subdivision, numbered in accordance with the plan proposed for registration;
- Existing contours at maximum 0.5m intervals within the subdivision and extended outside the subject lands far enough to determine the existing drainage pattern;
- Driveway, water service box locations and building envelopes;
- Elevations at existing trees, structures, watercourses, etc.;
- Centerline elevations of proposed and existing roads at maximum 15m intervals;
- Proposed elevations at front and rear building envelope;
- Proposed elevations at the corners of each lot and block and intermediate point of grade change;
- Proposed elevations at sideyard highpoints if applicable;
- Proposed 0.5m contours for grading within large blocks and parks;
- Proposed grades for major and minor overland flow routes;
- Lot fabric of subject lands including lot, block and easement description;
- Physical structures such as fencing, retaining walls, etc.;
- An arrow indicating the direction of the surface water run-off from all lots;
- All swales, other than the normal side yard swales, along with percent grade and the invert elevation of the swale at regular intervals;
- All rear yard catchbasins including the rim elevation of the catchbasin and the invert elevation of the outlet pipe;

- All terracing required with the intermediate grades specified;
- The lot grading plan shall make note of the typical grading details for various lot drainage types provided on separate detail drawings.
- Proposed locations for building envelopes and envelopes for private sewage disposal systems;
- All proposed easements for registration; and
- Heights of proposed retaining walls, fences etc.

3.2.14 Plan and Profile Drawing(s)

Plan - Profile drawings are required for all roads, service easements, drainage channels and Outlets.

Plan-profile drawings are to be drawn to a minimum horizontal scale of 1:500 and a vertical scale of 1:50 and are to include the following:

- Complete legend.
- All existing or future services, utilities and abutting properties.
- All services to be constructed.
- The profile portion of the drawing shall be a vertical projection of the plan portion whenever possible.
- All road allowances, lots, blocks, easements and reserves are to be shown and are to be identified in the same manner as on the Registered Plan.
- All curb and gutter and sidewalks shall be shown and dimensioned on the plan portion of the drawing.
- Where multiple drawings are required for one street, match lines must be used with no overlap or duplication of information.
- Where intersecting streets or easements are shown on a plan-profile, only the diameter of the pipe and direction of flow of the intersecting sewers shall be shown.
- On profile portion of drawings the type of sewer, diameter, length and grade shall be shown.
- On profile portion of drawings the water main diameter and length, shall be shown.
- Only the direction of flow and diameter of pipe shall be shown in the plan portion.
- All maintenance holes shall be shown on the plan and on the profile portions of the drawing and be identified by chainage and I.D. number and shall also be referred to the applicable

Standard Drawing or to a special detail on the profile portion of the drawing. All invert elevations shall be shown on the profile with each having reference to the north arrow.

- All sewer maintenance holes which have safety platforms are to be noted.
- All drop connections are to be noted and referred to the Standard Drawing.
- All catchbasins and catchbasin connections shall be shown. Catchbasins are to be numbered for easy reference. All rim and invert elevations for rear lot catchbasins are to be shown.
- All water mains, hydrants, valves, etc. shall be shown, described and dimensioned on the plan portion of the drawing. In addition, the water main shall be drawn to true scale size on the profile portion of the drawing and shall be described.
- The location of all storm, water and sanitary service connections shall be shown on the plan portion of the drawing using different symbols for each service.
- The centreline of construction with the 20 metre stations noted by a small cross shall be shown on the plan portion of the drawing.
- The original ground at centreline and the proposed centreline road profile shall be plotted on the profile. The proposed centreline road profile shall be fully described (length, grade, P.I. elevations, vertical curve data, high point chainages, low point chainages, etc.).
- Details of the gutter grades around all 90 degree crescents, intersections and culs-de-sac shall be provided on the plan portion of the drawing as a separate detail at a scale of 1:200.
- Chainage for the centreline of construction are to be shown on the profile portion of the drawing. The P.I., B.H.C., E.H.C., B.V.C. and E.V.C. chainages are to be noted.
- All existing services, utilities and features are to be shown on the plan portion. Those services and utilities below grade that are critical to the new construction shall also be shown in the profile.
- Profiles of roadways shall be produced sufficiently beyond the limits of the proposed roads, to confirm the feasibility of possible future extensions.
- The location of all luminaire poles shall be clearly shown on the plan portion.
- The proposed location and type of all street name and traffic control signs shall be shown on the plan portion.

3.2.15 Stormwater Management Plan(s)

Showing the proposed Stormwater Management Facility including the existing and proposed contours, cross-sections and details of structures and other elements associated with the proposed facilities, as appropriate.

3.2.16 Erosion and Sediment Control Plan(s)

Showing temporary erosion and sediment control measures to be implemented on the site. Refer to Section 7.10 for additional information required on the plan. Temporary construction access location and details to be provided on this plan. Scale 1:1000.

3.2.17 Composite Utility Plan(s)

Composite Utility Plan shall be prepared in the same format as “General Plan of Services” and showing the location of hydrants, trees, entrances, poles, street lights, transformers, water shut-offs, etc.

3.2.18 Traffic Management Plan(s) Traffic Management information

Traffic Management information to be included (e.g., pavement markings, signage, etc.), unless the drawing becomes too congested, in which case a separate Traffic Management Plan may be submitted. Showing Canada Post boxes and traffic controls. Scale 1:500.

3.2.19 Landscape Drawings

All landscape plans shall be drawn and stamped by a Full Member of the Ontario Association of Landscape Architects. All landscape plans shall be drawn at a minimum scale of 1:500.

The landscape drawings may include the following:

- Tree Preservation Plan and Details;
- Streetscape and Buffer Planting Plans and Details;
- Detailed Park Development Plans and Details;
- Trails Master Plans and Details;
- Landscape Restoration Plans and Details;
- Stormwater Management Facility Planting Plan;
- The Streetscape Plan shall show the following:
 - existing trees and natural features to remain;
 - building envelopes, driveways and sidewalks;

- walkways, trails and easements;
- required fencing including privacy, acoustic and chain link;
- proposed plantings;
- entry features;
- location of street lighting;
- location of public utility boxes and easements and hydrants; and
- heights of existing and proposed retaining walls, fences etc.

Construction details will be required for all landscape elements to be implemented as part of the development.

3.2.20 Tree Inventory, Assessment and Preservation Plan and Detail(s)

Refer to Section 11.10.3.

3.2.21 Parkland Development Drawings

The Developer shall be responsible to prepare a detailed Grading Master Plan for approval by the Town, for all lands to be dedicated for park purposes. This plan shall show all existing trees and features that are in conformity with the end use of the park and that are to remain. All other trees shall be removed by the Developer subject to approval. Prior to preparing park development plans, the Developer shall meet with Town staff to review Town recreational needs, i.e. soccer pitches, ball diamonds, etc.

This Master Plan shall be prepared at a scale of 1:500 and form part of the approved Engineering Drawings, indicating the following, at a minimum:

- Existing contours at a maximum of 0.5 m intervals;
- Drainage structures and direction of overland drainage;
- Species and size of existing plant material to remain and be protected;
- Species and size of plant material to be removed;
- Proposed underground services, as required;
- Layout of all proposed recreation facilities;
- Layout of parking lot and spaces (including handicapped parking);
- Layout of all trails;
- Proposed site amenities including benches, bike racks, trash receptacles, signs, washrooms;

- Perimeter fencing;
- Park lighting;
- All surface treatments; and
- All proposed plant materials.

3.2.22 Streetlighting Plan(s)

Showing the underground ducts, streetlight schematic, photometric data (point plot) and details. Scale 1:1000.

Plans showing the location and design of all exterior lighting including lighting specifications. Any exterior lighting needs to be adequate for the site and generally by directed inward and down into the site. Lighting should be designed to avoid causing ambient light pollution. Reducing light trespass on adjacent properties is best accomplished by the use of full cut-off fixtures, low wattage bulbs and flat glass fixtures to reduce glare.

The plan shall include, but shall not be limited to, the following information:

- Proposed lighting levels shown in 5m x 5m grid or contour lines.
- It is recommended that a minimum lighting level of 0.5 fc at the property line be provided, however, the level of 0.5 fc shall not exceed 1.5 m beyond the limits of the property. Show lighting levels 5 metres beyond the property line.
- The location of all buildings, structures and use areas on the property.
- The location, number, type, position, elevation and mounting height of all outdoor light fixtures. Lamp types are to be LED.
- The number and location of outdoor light fixtures to be equipped with automatic timing devices.
- Any other features which may affect the nature, intensity or direction of light emission from outdoor light fixtures.
- Outdoor Light Fixture are not to be installed at a mounting height in excess of 9.2 meters above grade. Mounting height refers to the height measured from grade to the underside of the lamp, or the highest of the lamps if there is more than one lamp.
- Every Lot shall have a sufficient number of Outdoor Light Fixtures equipped with Automatic Timing Devices which turn off the Outdoor Light Fixtures between 11 p.m. and sunrise.
- The Average Maintained Horizontal luminance of all outdoor areas on a Lot is not to exceed 16.4 lux (1.5 footcandles).

- In an area used for the outdoor display of merchandise for sale, provided that the applicable zoning by-law and other applicable law permits such outdoor display of merchandise, the Average Maintained Horizontal Luminance is not to exceed 215.2 lux (20 footcandles).
- Where vertical surfaces of Buildings or other structures are illuminated for decorative purposes or for any other purpose, the Average Maintained Vertical Luminance of such vertical surfaces is not to exceed 64.6 lux (6 footcandles). 1
- Description, calculations and technical information regarding all outdoor light fixtures, including; power (in watts), type of light source, filtering, information as to light distribution in the horizontal and vertical planes, information as to light distribution in the horizontal plane between 11:00 p.m., and sunrise the following day and manufacturer's catalogue information and drawings.
- An illumination statistics table indicating the provided lighting data and the allowable illumination statistics.

3.2.23 As-Built Drawings

The Consultant shall keep one set of the most recent signed drawings solely for As-Built recording purposes. The Consultant shall record neatly, in red ink, any deviations from the above original signed drawings on the As-built drawings as the work is performed. Deviations shall include changes, additions, deletions, and different site conditions encountered. All deviations shall be recorded, including (where applicable):

- watermain information to include: swing ties and elevation of inverts for all structure connections, services, pipe at 50 metres intervals, structures (to centre of frame and grate, size, type and class of pipe);
- sewer information to include: swing ties and elevation of inverts for all structure connections, services, pipe at 50 metre intervals, structures (to centre of frame and grate, size, type and class of pipe);
- rural road information to include: culvert inverts, storm outlet ditch inverts, ROW cross-sections at 50 metre stations;
- urban road information to include: ROW cross-sections at 50 metre stations;
- drawings shall be signed by the author;
- drawings may be accompanied by digital record;
- swing ties shall be at least two measurements from other surface elements of the work and the time being located. Service swing ties shall be related to the front lot corners of the subject land;

- hydro, telecommunication and gas information to include: location of transformers, pedestals, drop/secondary terminations, preliminary routing and lengths, secondary routing and lengths, wire sizing, conduit sizing, pipe sizing, concrete encasement locations, off-sets and swing ties to lot fabric;
- streetlight information to include: location of lights and pedestals; wire size and routing; and
- ESA inspection certificate for all wiring not owned by primary hydro authority.

The As-Built drawings shall be kept in the field office, or in the Consultant's possession if no field office was required as part of the Contract. The As-Built drawings shall be available for review immediately upon request by the Town throughout the duration of construction. Failure to record changes in a timely manner may result in delays to security reductions.

The drawings must be legible and clean. The Town will not consider As-Built drawing submissions without the details noted above. Failure to deliver As-Built Drawings upon request will result in a delay to security reductions.

As a minimum, an underground set of As-built drawings must be provided as part of the certification of the underground works such that the operators of the system have the information on hand as is required as a condition of the MECP Environmental Compliance Application (ECA). A final As-built drawing set must be provided in AutoCAD format prior to the final Assumption/Acceptance of the development.

As-built drawings shall be prepared in accordance with current PEO Guidelines available using the link provided below:

<https://www.peo.on.ca/sites/default/files/2020-04/PrepAsBuiltRecordGdln-Mar2020.pdf>

3.2.24 Service Record Sheets

Complete set of individual service record sheets shall be submitted. Each service record sheet shall show the location, size, material, and invert elevation of the storm, sanitary and water services tied to the house foundation or other acceptable aboveground utility furniture.

4 Water Supply System

Municipal water supply systems shall be designed in accordance with current Ministry of the Environment, Conservation and Parks Guidelines and guidelines established by the Fire underwriters Survey. Watermains shall be adequate size to provide service for the development of adjacent lands designated by the Town.

The functional-servicing report(s) shall address the requirements for water supply to service the Development. Should the existing supply system not have sufficient capacity to provide for new development, the Developer's Engineer shall provide a Hydrogeological Report commenting on proposed sources for additional water supply and how any impacts on the existing ground water regime will be mitigated.

Fire flow protection and storage provisions shall be reviewed with the Town of Erin for each development during the initial stages of Draft Plan Approval. Any expansions to the existing water systems, together with the requirements for additional wells, storage facilities and/or trunk mains will be resolved at that time.

Where connections are to be made to an existing municipal system, the capacity of existing wells and storage facilities will be considered when reviewing the requirements for new source wells and storage facilities. All water supply systems shall incorporate provisions for standby power, metering, chlorination, fire storage, pre-charged tanks to buffer the well pumps and security fencing of the site.

5 Watermains

5.1 GENERAL

The water distribution system is to be designed as a network system to meet the water demand for each area or development under consideration. To ensure reliability, a looped system must be provided to the satisfaction of the Town.

5.2 CONFIRMATION OF AVAILABLE CAPACITY

Prior to the commencement of any design, the developer and/or designer must contact the Town and confirm there is adequate system capacity to accommodate the proposed project.

5.3 SERVICE AREA

The system shall be designed to service all areas within the development to their maximum future capacity in accordance with the Town's current Official Plan and Zoning By-Law maximum densities. Allowance shall be made for connection to appropriate watermains in adjacent developments or future growth areas. The exact location for these connections shall be approved by the Town.

5.4 DESIGN FLOWS

Watermains shall be designed to meet the greater of the maximum day demand plus fire flows or peak hour demand.

5.4.1 Population and Equivalent Population

The estimated populations and development areas shall be in accordance with the Town's Official Plan and Zoning By-Law.

For local watermains, the following population densities are to be used to estimate residential water demands:

Table 1: Population and Equivalent Population

| Unit Type | People/Unit |
|--|-------------------------|
| Single Family | 2.8 |
| Townhouses | 2.8 |
| Apartments | 2.65 |
| Schools | 60 / hectare |
| Light Industrial (No Major Office Component) | 70 / hectare |
| Offices | 150 / hectare |
| Commercial (Retail) | 100 / hectare |
| Heavy Industrial | Use First Principles |
| Mixed Use | 330 ppl/hectare of site |

In the absence of sufficiently detailed development concepts, the following unit densities shall be used, unless otherwise specified in the Official and/or Secondary Plans:

- Single Family and Semi-Detached 24 units per site hectare
- Townhouses 40 units per site hectare
- Apartments 75 units per site hectare

For the design of trunk watermains, population estimates may be based upon census data or other reliable means of estimation.

5.4.2 Consumption Rates

Table 2: Consumption Rates

| DEVELOPMENT TYPE | AVERAGE DAILY DEMAND RATE |
|------------------|---------------------------|
| Residential | 290 L/capita/day |
| Schools | 95 L/student/day |
| Industrial | 9 m ³ /ha/day |
| Commercial | 28 m ³ /ha/day |

The Town reserves the right to allow or impose alternative standards when there is specific land use and demand information is available.

5.4.3 Peaking Factors

The following peaking factors shall be applied to the average daily demand:

- Minimum Hourly Demand Peaking Factor: 0.40 or from MECP Guidelines.
- Maximum Daily Demand Peaking Factor: 2.75 or from MECP Guidelines.
- Maximum Hourly Demand Peaking Factor: 4.13 or from MECP Guidelines.

5.4.4 Fire

The fire flows shall meet the following minimum criteria outlined in the table below.

Table 3: Fire Flow Requirements

| DEVELOPMENT TYPE | MINIMUM ALLOWABLE FLOW RATE | PREFERRED FLOW RATE |
|-----------------------|--|--|
| Residential (SFD) | 57 L/s @ 138 kPa 750 gpm @ 20 psi | 76 L/s @ 140 kPa 1000 gpm @ 20psi |
| Institutional | 91 L/s @ 138 kPa 1200 gpm @ 20 psi | 114 L/s @ 140 kPa 1500 gpm @ 20 psi |
| Industrial/Commercial | 136 L/s @ 138 kPa 1800 gpm @ 20 psi | 152 L/s @ 140 kPa 2000 gpm @ 20 psi |

For specific uses such as multi-unit and multi-storey residential development, fire flows are to be determined based on the most recent publication of the Fire Underwriters Survey of the Insurance Bureau of Canada or AWWA Manual M31 - Distribution System Requirements for Fire Protection.

5.5 WATERMAIN SIZING

The Hazen-Williams formula shall be used for computing friction losses and subsequently sizing the watermains.

$$Q = 0.84918 (C) (A) (R)^{0.63}(S)^{0.54}$$

where Q = Flow Rate (m³/sec.)

C = Coefficient of Roughness, see following for C value

A = Cross-Sectional Flow Area (m²)

R = Hydraulic Radius (m)

S = Slope of Energy Grade Line (m/m)

For new PVC or Concrete mains, the Hazen-Williams factors, "C", shall be as follows:

C = 100 for 150 mm diameter

C = 110 for 200 mm and 250 mm diameter

C = 120 for 300 mm to 600 mm diameter

C = 130 for pipe diameter over 600 mm

The minimum size of watermain shall be 150 mm diameter in residential developments, except beyond last hydrant on cul-de-sacs where the minimum diameter of watermain shall be 50mm. The minimum size of watermain shall be 200 mm diameter in industrial, commercial, and institutional developments.

A hydraulic network analysis of the water distribution system is required for all extensions to existing distribution systems.

5.6 WATERMAIN PRESSURE

The minimum pressure during maximum daily demand (MDD) shall be 345 kPa (50 psi).

The minimum pressure during the peak hourly demand (PHD) shall be 275 kPa (40 psi).

The minimum pressure when the system is tested under fire flow conditions in conjunction with the maximum daily demand shall be 140 kPa (20 psi).

The maximum pressure under static load or during the minimum hourly demand shall be 550 kPa (80 psi).

5.7 OVERSIZING

Oversizing of watermain will be provided as required to provide for adjacent areas where service is expected to be extended, and to provide fire flow requirements including oversizing of hydrants, openings and leads as required.

5.8 WATERMAIN LAYOUT

Watermain shall generally be located at 4.8 m from south or east street line. Refer to typical road cross-sections in [Appendix A](#) for guidance.

When watermain are located in easements, the easement width shall be as follows:

Table 4: Watermain Easement Standard Specifications

| PIPE DIAMETER | DEPTH OF PIPE (m) | MINIMUM WIDTH OF EASEMENT (m) |
|---------------|-------------------|-------------------------------|
| 150 to 375 mm | 3.0 m maximum | 3.0 metres |
| 450 to 750 mm | 3.0 m maximum | 5 metres |
| 750 to 900 mm | 3.0 m maximum | 6.0 metres |

For easements containing more than one pipe or underground service the minimum width will be based on the above chart for the maximum pipe size plus 3.0 metres. Regardless of the preceding, all situations will be reviewed on a case by case basis at the discretion of the Town.

Easements are to be located on one side of the common lot line between adjacent lots to ensure access is only required by one property owner and to ensure perimeter fences are not located along the length of the easement.

5.9 DEPTH OF COVER

For urbanized roads a minimum depth of cover of 1.8 m below finished ground surface or road centreline, whichever is greater, is required.

Along open ditches, or unimproved roads, an increased cover may be requested by the Town to allow for future road improvements or lowering of road profile when urbanization occurs.

The maximum height of cover is not to exceed 2.2 m unless pipe strength design calculations are provided for approval by the Town.

In zones where minimum cover cannot be provided design of pipe insulation must be submitted by the Engineer for approval by the Town.

5.10 PIPE CLEARANCE

Clearances at sewer and watermain crossings shall be in accordance with MECP guidelines. Where clearances cannot be achieved the design shall be completed in accordance with MECP Procedure F-6-1.

5.11 BEDDING AND BACKFILL

All watermain and appurtenances are to be installed with granular 'A' bedding and a minimum of 300 mm of sand backfill over the pipe in accordance with OPSD 802.010 or 802.030 to 802.032, as applicable. Compaction shall be to a minimum of 95% SPMDD or as indicated in the approved Geotechnical Report.

5.12 RESTRAINING

All joints are to be mechanically restrained in fill areas, as per manufacturer's recommendations.

Concrete thrust blocking shall be installed at all tees, vertical and horizontal bends, hydrants, ends of watermain and connections 100 mm and larger, as per OPSD 1103.010 and OPSD 1103.020.

All watermain and thrust restraints shall be designed to withstand the maximum operating pressure, plus the transient pressure to which it will be subjected. The value of transient pressure will not be less than the pressure surge that would be created by immediate stoppage of water column moving at 0.6m/s. The design pressure shall not be less than 150psi (1034kPa) in any case.

5.13 DEFLECTION OF WATERMAIN

If it is necessary to deflect a watermain to avoid a conflict with other infrastructure. The maximum permissible vertical bend shall be 45° and the minimum length of the deflected watermain shall be 1.5 m.

Using 90° horizontal bends should be avoided where alternatives exist.

All fittings installed along watermain should not be located under any under service line, utility line, concrete curb or any other element restricting direct access to the pipe.

5.14 SUPPORTING OF WATERMAIN

Where crossing an existing watermain, if more than 0.9 m of the watermain will be exposed, the designer will be required to provide detailed drawings showing how the watermain will be supported during construction for approval by the Town.

5.15 TERMINATION OF WATERMAIN

Design proposal for the watermain system shall ensure that adequate water quality requirements are met. Water distribution systems should be designed without any dead-end pipes.

Where dead-end watermain is allowed, a restrained valve shall be provided at dead end. The valve shall be located beyond the last service and 4 m from the end plug and blocking. A blow-off is to be provided between the valve and plug. All dead end mains to be provided with a dedicated sampling station.

5.16 FIRE HYDRANTS

Hydrants shall be installed in accordance with **TOESD 703**, complete with thrust blocks and mechanical restrainers.

Hydrants shall be located as per the typical road cross-section and generally on projections of lot lines, at the end of all cul-de-sacs. On rural cross-sections, hydrant access behind the ditch, complete with access culvert, is to be provided.

The maximum spacing for hydrants shall be a 120 m radius from the hydrant, for single family residential areas, 90 m for town house development areas, industrial, commercial and institutional land uses, or as required by the Town's Fire Department.

Hydrant flanges shall be set at 100 mm to 200 mm above finished grade at the hydrant.

In areas where the water table is known to be high, the Town may request that the drain holes of the hydrant be internally plugged. Yellow stripe to be painted on hydrant if drain port is plugged.

Hydrants shall be colour-coded in accordance with NFPA 291-1977, "Fire Flow Testing and Marking of Hydrants". All hydrants shall be flow tested by the Developer prior to Final Acceptance of the municipal services by the Municipality. A copy of the flow testing report shall be provided to the Fire Chief as well as the Town Engineer.

All hydrants to be painted red by the manufacturer with silver caps prior to delivery to the site.

5.17 VALVES

The size of main line valves shall be equivalent to the size of the watermain. All valves to be counter clockwise opening. Valve boxes located in the traveled portion of the roadway shall have screw type boxes. Valve boxes located in grassed boulevards shall have slider type boxes.

Valves shall be located as required to meet spacing and intersection requirements, or as required by the Town.

Generally, three (3) valves shall be placed at cross-intersections and two (2) valves at tee intersections. Valves shall be spaced such that no more than forty (40) dwelling units are isolated at one time. In addition, the maximum permissible spacing between valves shall be 250 m for distribution/servicing watermains, and 300 m for trunk supply watermains.

All valves 450 mm diameter or greater shall be installed in a concrete valve chamber.

Air release valves shall be provided at high points of all trunk watermains and, where possible, installed together with valves in valve chambers. Further, where possible, fire hydrants shall be located at all highpoints to minimize the negative impacts of trapped air.

Where confirmed by the water modelling calculations, pressure reducing valve complete with chambers must be installed.

Watermains crossing creeks, railways and provincial highways shall have a valve on each side of the crossing.

5.18 WATER SERVICES

Single 25 mm diameter water services with a curb stop at 0.3 m in front the property line is to be located at the centre of each residential lot.

Water services to commercial, industrial, institutional, and multiple use shall be sized for the specific land use and approved by the Town.

A minimum 25 mm water service shall be provided to park areas with a non-freeze post hydrant. Actual size of the service will be confirmed during design process based on type of facilities being installed in the park.

Single services for a residential lot shall be located in accordance with **TOESD Division 600**. The location of a water service for commercial, institutional, or industrial use will be considered on an individual basis.

Water services shall be located at a minimum depth of cover of 1.8 m with the curb stop out of the future driveway.

When water service line is in conflict with any main service pipe (typically storm sewer main), the water service must be installed below the storm sewer with separation as required by MECP Procedure F-6-1. Creation of high points along water service line is not allowed, with exception of horizontal goose neck, established near main stops.

5.19 WATER SAMPLING

Water sampling stations shall be provided where directed by the Town. In general, one (1) sampling station is required at a rate of one (1) per three-hundred (300) units. Sampling Station should be located within municipal ROW or in a corner area of municipal blocks (e.g. parks, parkettes). Locations in the intersection areas are not allowed.

5.20 FIRE DEPARTMENT CONNECTIONS

Fire department connections may be required for industrial, commercial, or institutional developments. Configuration of the fire and domestic water service connection is to be confirmed by the Town during pre-submission consultations.

5.21 WATER METERS

A water meter is required for each water service. The water meter will be sized by the Town using the peak instantaneous flow provided by the designer.

5.22 TRACER WIRE

A tracer wire is to be provided along the top of the entire length of watermain, secured at every fitting and valve and at intervals not exceeding 5.0 m.

Tracer wire is to be brought to the surface at all valves.

Tracer wire is to be continuous, with no joints. Where the ends of rolls must be connected, waterproof connectors are required.

5.23 CATHODIC PROTECTION

Cathodic protection shall be provided in accordance with the recommendations in the soils report.

At a minimum, sacrificial caps are to be provided on every bolt of all mechanical joints and restrainers. The bolt lengths shall be sufficient to accommodate the caps.

5.24 CAUTION TAPE

When the watermain has been installed in non-standard locations, blue caution tape is to be installed, along its length, between 0.3 m and 0.5 m above the watermain.

5.25 TESTING AND DISINFECTION

The following testing requirements apply to all new sections of watermain. Any sections which fail to meet the requirements shall be repaired or replaced at the direction of the Town.

A temporary bypass connection is to be installed to permit testing of the system.

5.25.1 Swabbing

All watermains 600 mm diameter and less shall be swabbed. All swabs are to be new and a minimum of one (1) size larger than the watermain diameter. For diameters larger than 600 mm in diameter, swabbing is to be discussed and approved in conjunction with the Town.

5.25.2 Hydrostatic Testing

Hydrostatic testing shall be performed on the completed distribution system in accordance with OPSS 441/AWWA C605. For polyethylene pipe, the testing shall be completed in accordance with OPSS 441. Testing of sections that consist of varying pipe materials will not be permitted.

All fire hydrant valves and main line valves must be open during testing with the exception of those main line valves being used to divide the system into sections for the purposes of testing.

5.25.3 Disinfection

The system shall be disinfected using the “continuous feed” method in accordance with AWWA C651. Following the required twenty-four (24) hour contact time, the system is to be flushed. The chlorinated water must be neutralized using an appropriate chemical such as sodium thiosulphate.

5.25.4 Bacteriological Testing

Samples for bacteriological testing shall be collected, a minimum of twenty-four (24) hours after flushing is completed, in accordance with AWWA C651. Two consecutive sets of samples are required.

For a test result to be deemed acceptable, the bacterial analysis of sampled water must indicate the following:

Total Coliform - 0 CFU/100ml

E. coli - 0 CFU/100ml

Background - <200 CFU/100ml

Should the results of the sampling be deemed unacceptable, additional swabbing, disinfection, flushing, and sampling may be required at the Town’s discretion.

In the event that the final connection is not made within ten (10) days of the receipt of the acceptable test results, the Town will take a residual chlorine reading. If the residual free chlorine has fallen below 0.05 mg/L the Town will require additional flushing and sampling of the system prior to final connection.

5.25.5 Final Connection

The final connection shall not be made until all of the required testing and disinfection has been satisfactorily completed and approved by the Town. The connection to existing water infrastructure shall be completed under the supervision of the Town of Erin in accordance with current Ministry of the Environment Regulations and the Town of Erin Water Connection Requirements.

The length of pipe required to connect the new water system to the existing distribution system shall not exceed 5.5 m and shall be disinfected prior to installation in accordance with AWWA C651.

5.25.6 Continuity Testing

A continuity test of the tracer wire shall be completed by the Contractor's forces with point to point readings recorded and approved by the Town.

5.25.7 Fire Hydrant Flow Testing

Hydrants are to be flow tested in accordance with NFPA Standard 291.

All hydrants are to be painted as follows:

- a) Body - Tremclad fire engine red.
- b) Font Nozzle - Tremclad black.
- c) Top and size nozzle caps - as per the results of the flow testing noted below.

Table 5: Fire Hydrant Colour

| CLASS | CAPACITY | COLOUR |
|----------|---|------------------------------|
| Class AA | > 5680 L/min (>95 L/sec) | Tremclad - Safety Light Blue |
| Class A | 3785 L/min to 5675 L/min (63 L/sec to 95 L/sec) | Tremclad - John Deere Green |
| Class B | 1900 L/min to 3780 L/min (32-63L/sec) | Tremclad - Safety Orange |
| Class C | < 1900 L/min (<32 L/sec) | Tremclad - Safety Red |

Flow testing shall be coordinated with the Town.

5.26 MATERIALS

Watermain pipe: Polyvinylchloride, C900, Class 150, (DR 18) with Ring-Tite joints.

Fittings: Ductile Iron, fully cement lined, mechanical joint complete with mechanical joint restraints.

Hydrants: Canada Valve Century Type as specified by the Town with 150 mm lead and valve and Stortz pumper nozzle. Hydrant thread to be reviewed with the Fire Department before ordering.

Valves: All valves to be resilient seated gate valves.

Services: Type K copper pipe.

6 Wastewater Pumping and Treatment

The requirements for wastewater disposal shall be discussed in the functional servicing report. Prior to the Town approving the Draft Plan and the issuance of Conditions of Draft Approval by the approval authority, the method for disposing of wastewater will be determined for the development either by means of a municipal, communal sewage or individual sewage systems. In keeping with the Provincial Policy Statement 2005 all urban/suburban development will eventually be connected to a municipal sewage system. Within the urban boundaries, development shall be required by agreement to connect to municipal servicing when it becomes available adjacent to development.

All new development within the urban boundaries as shown in the Official Plan will agree to connect to municipal water and sewage systems once water and sewage services are provided to the property line. This agreement will be registered on title as a condition of any approval.

6.1 COMMUNAL WASTE DISPOSAL SYSTEMS

Municipal and communal sewage collection and treatment systems shall be designed in accordance with current Ministry of the Environment, Conservation and Parks Guidelines and Town of Erin standards.

A Report outlining the soils capabilities of the site for sewage disposal shall be submitted with the Draft Plan. Additional soils testing required by the Town or The Ministry of the Environment, Conservation and Parks will be completed as part of the design and any special requirements for construction or restricted areas shall be identified prior to Draft Plan Approval.

6.2 PRIVATE WASTE DISPOSAL SYSTEMS

Individual sewage systems shall be designed in accordance with the Ontario Building Code, where permitted in rural areas.

6.3 SEWAGE PUMP STATIONS

The following sections discuss the design of sewage pumping stations. In addition to the guidelines and standards included here, all sewage pumping stations must be designed in accordance with current MECP guidelines.

All equipment shall meet the Town's Approved Product, Equipment and Suppliers List. This List shall be obtained from the Town at the pre-design stage.

6.3.1 Station Capacity

Sewage pumping stations shall be designed with sufficient capacity to accommodate the design peak instantaneous flow from the ultimate tributary area. Allowances shall be made in the design such that with minor modifications, the pumping station capacity may be upgraded (e.g. upgrade or addition of pumps, motors, forcemains, etc.) to handle future peak flows from the ultimate tributary area. In certain instances, it may be more economical to initially over-design the pumping station for future flows rather than upgrading at a later date. In these instances, pumping station operations should be evaluated at various flow rates anticipated during the design life.

6.3.2 Site Considerations

The site for a sewage pumping station shall be selected after making detailed investigations as to the present and future needs of the developing area. The station shall be located to ensure that its tributary area is serviced with the minimum amount of cost.

The following shall also be reviewed when considering the site location of a sewage pumping station:

- Type of station, the capacity, and the type and number of pumps to be used;
- Soil investigations (i.e. rock or high water table resulting in increased construction cost);
- Flood protection shall be considered when designing sewage pumping stations. Sewage pumping stations shall be designed to be protected from damage during the 1:100 year storm and shall remain fully operational and accessible during the 1:100 year storm event. Regulations/requirements of municipalities, provincial and federal agencies regarding flood plain obstructions must be considered;
- Vehicle access and parking must be provided for inspection and maintenance of the station. The pumping station shall be readily accessible by maintenance vehicles during all weather conditions;
- Structural, architectural and/or landscaping design of the station to ensure that it does not detract from the surrounding area;
- Availability of utilities such as electric power (i.e. voltage to operate electric motors), gas power, potable water, fire protection and telephone service;
- A junction maintenance hole will be required to allow for one inlet into the well;
- Odour control is required to limit impacts at the location of sensitive receptors;
- Noise control is required to limit impacts at the location of sensitive receptors; and

- Backup power.

6.3.3 Types of Pumping Station

There are four major types of sewage pumping stations that the designer may consider for site specific conditions: wet well/dry well, wet well/submersible, suction lift and screw pump. Pumping station type selection must be approved by the Town. It should be noted that preference will be given to the wet well/submersible type pumping station.

6.3.3.1 Wet Well/Dry Well Pumping Station

In a wet well/dry well pumping station, the pumps, motors and controls are located below grade in a dry well, located immediately adjacent to the wet well. The wet well is used to collect and temporarily store wastewater.

6.3.3.2 Wet Well or Submersible Pumping Station

The wet well or submersible pumping station has submersible pumps located in the same below grade chamber into which the wastewater flows. The pumps are located within the wet well and the controls are typically mounted above grade.

6.3.3.3 Suction Lift Pumping Station

Suction lift pumping stations incorporate self-priming pumps in order to locate the pumps above the water level, and either eliminate or decrease the depth of the dry well.

6.3.4 Pumps

To determine the appropriate pumps for installation in the sewage pumping station, the following data must be included with the design submission. Final equipment selection must meet the approval of the Town.

Multiple pumps shall be provided. Where only two units are provided, they shall be of the same size, to provide a firm capacity with one unit out of service and at least capable of handling the 10 year design peak hourly flow. The designer should ensure that all pumps will be subjected to hydrostatic and operating tests performed by the manufacturer.

Where a bar screen is required, preceding the pump, a mechanical hoist is needed. Where the size of the installation warrants, mechanically cleaned and/or duplicate bar screens shall be provided.

Pumps handling sanitary sewage from 750 mm or larger diameter sewers shall also be protected by bar screens. Appropriate protection from clogging shall also be considered for small pumping stations served by smaller sanitary sewers.

Except where grinder pumps are used, pumps handling raw sewage should be capable of passing spheres of at least 75 mm in diameter. Pump suction and discharge openings shall be at least 100 mm in diameter.

The pump shall be so placed that, under normal operating conditions, it will operate under a positive suction head, except where suction-lift pumps are used.

Each pump shall be equipped with a time totalizer and provision for automatic or manual alteration of the lead pump.

Each pump shall have an individual intake. Wet well and intake design shall be such as to avoid turbulence near the intake and to prevent vortex formation.

A sump pump equipped with dual check valves shall be provided in the dry well to remove leakage or drainage with discharge above the maximum high water level of the wet well. All floor and walkway surfaces shall have an adequate slope to a point of drainage. Pump seal leakage shall be piped or channeled directly to the sump. The sump pump shall be sized to remove the maximum pump seal water discharge that would occur in the event of a pump seal failure. Pumping station designs shall be based on system-head calculations and curves for three conditions using appropriate Hazen-Williams factor “C” as follows:

- a) Low sewage level in the wet well, $C = 120$;
- b) Median sewage level over the normal operating range in the wet well, $C = 130$; and
- c) Overflow sewage level in the wet well, $C = 140$.

System-head curve (b) should be used to select the pump and motor since this will reflect the normal operating condition. The extreme operating ranges will be given by the intersections of curves (a) and (c) with the selected pump curve. The pump motor shall be able to operate satisfactorily over this full range (i.e., between conditions (a) and (c)).

Although it is normal to size pumps and motors for design peak instantaneous flows, consideration shall be given to how the future and ultimate sewage flow requirements can be handled. Ultimate sewage flows would account for the build-out of the catchments area. These operating points shall also be shown on the system-head curves.

Where pumping stations are discharging directly to a sewage treatment plant or into a pumping station (i.e., forcemain directly into wet well of a downstream pumping station), some means of flow pacing is needed. This is provided most commonly by variable speed drives, depending upon the degree of flow pacing necessary. If even minor pump surges will have serious effects, variable speed pumps shall be used. If small surges can be tolerated, two speed or multiple speed pumps may be used.

The pumps and controls of main pumping stations, and especially pumping stations discharging to or operated as part of a sewage treatment plant, shall be selected to operate at varying delivery rates. In addition, where practical, such stations shall be designed to deliver as uniform a flow as feasible in order to minimize hydraulic surges. The firm design capacity (with the largest unit out of service) of the pumping station serving sanitary sewers shall be based on design peak instantaneous flow and shall be adequate to maintain a minimum velocity of 0.6 m/s in the forcemain.

6.3.5 Wet Wells

Where continuity of pumping station operation is critical, consideration shall be given to dividing the wet well into two sections, properly interconnected, to facilitate repairs and cleaning (including automatic cleaning devices). Divided wet wells shall be considered for all pumping stations with firm capacities in excess of 100 L/s (1600 USgpm).

The design fill time and minimum pump-cycle time shall be considered in sizing the wet well. The effective volume of the wet well shall be based on design average daily flow, and a filling time not to exceed 30 minutes, unless the facility is designed to provide flow equalization. Other factors that shall be considered include volumes required for pump-cycling, dimensional requirements to avoid turbulence problems, vertical separation between pump and control points, sewer inlet elevation(s), capacity required between alarm levels and basement flooding and/or overflow elevations, and number of and horizontal spacing between pumps.

The minimum surface plan area of a wet well shall be 4.9 m² (53 ft²) [i.e. 2.5 m (8.2 ft) diameter or 2.25 m (7 ft) square]. Wet wells shall not provide excessive retention times, due to potential odour problems. The designer shall ensure that easy and efficient removal of pumps, motors, and other mechanical and electrical equipment is provided. A suitable and safe means of access for persons wearing self-contained breathing apparatus needs be provided to wet and dry wells and valve chambers. Equipment such as access hatches, ladders, service platforms, guards, grates, and handrails, shall be constructed of a suitable material when exposed to wet and/or corrosive conditions.

For pumping stations equipped with 50 kW (67 hp) or smaller pumps, the wet well shall be of sufficient size to allow for a minimum cycle time of 10 minutes for each pump.

To achieve this minimum detention time in a two-pump station using constant speed pumps, the volume in cubic metres (m³), between pump start and pump stop shall be 0.15 times the pumping rate of one pump, expressed in L/s. For two-speed or variable speed pumps, pumps over 50 kW (67 hp), or for other numbers of pumps, the required volume depends on the operating mode of the pumping units. The pump manufacturer's duty cycle recommendations shall be utilized in selecting the minimum cycle time. When the anticipated initial flow tributary to the pumping

station is less than the design average daily flow, provisions shall be made so that the fill time indicated is not exceeded for initial flows. When the wet well is designed for flow equalization, as part of a sewage treatment plant, provisions shall be made to prevent septicity.

The wet well floor shall have a minimum slope of 1 to 1 to the hopper bottom. The horizontal area of the hopper bottom shall be no greater than necessary for proper installation and function of the inlet. The cross-sectional area of the wet well above the benching shall be constant for the full depth of the wet well.

Access to the wet well shall always be from the outside. An access ladder shall be provided from the top of the slab to the service platform, and a separated ladder from the platform to the bottom of the well.

The opening to the wet well shall be no smaller than 750 by 900 mm, or 900 mm in diameter. The cover shall be equipped with a lock and pry lip and include a safety rail around the access. The opening edge shall be flush with the vertical wall of the wet well. The opening to the wet well shall be on the wall giving access to float controls, bubbler lines and similar equipment, without the necessity of entering the wet well.

The need for and type of screening facilities required for pumping stations varies with the characteristics of the sewage. For submersible pumping stations, screening may not be required, but for wet well/dry well stations, it is generally accepted practice to provide screening in the form of a basket screen or a removable bar screen. Although some basket screens may be cumbersome to remove and empty, their installation provides the advantage of not requiring entry of operating staff into the wet well for cleaning operations. With basket screens, guide rails shall be tubular and similar to submersible pump rails. Manually cleaned bar screens shall be sloped at 60° and have 38 mm clear openings. The vertical sides shall be solid. The minimum width shall be 600 mm. A drain platform shall be provided for screenings.

All wet wells need to be provided with ventilation. Natural ventilation will usually suffice for small pumping stations where access is limited. This can be achieved through two (2) 100 mm diameter vent pipes. Vents shall be equipped with a gooseneck at the top, extending 900 mm above the top of the slab of the wet well. The vents shall be equipped with an insect screen. One vent pipe shall extend within 300 mm of the crown of the inlet sewer and the other shall terminate on the underside of the roof slab. Natural ventilation can be supplemented with portable ventilation units. Adequate provisions for fresh air entry of all wet wells shall be followed. In some cases, mechanical ventilation may be preferred. In locations adjacent to sensitive receptors, such as schools or recreation sites, the need for supplemental odour control shall be evaluated and, if required, suitable equipment installed.

In wet well/ dry well installations, the air bubbler line (if used) and sump pump discharge shall be raised above the overflow elevation and shall cross between the wells below the frost line. A service platform is normally required to allow for servicing of equipment and bar screen cleaning (if used).

6.3.6 Dry Wells

Guidelines for dry well design are listed as follows:

- The floor of the dry well shall be sloped towards a sump, equipped with sump pump. The discharge piping from the sump pump shall enter the wet well at an elevation above the maximum overflow level. Check valves will be installed to prevent any chance of back flooding from the wet well;
- A flood alarm shall be installed in the dry well;
- No water service shall be provided in the dry well without suitable backflow preventer as flooding may be possible. The water service capacity must not exceed the sump pump capacity;
- Mechanical ventilation of the dry well must be provided and all Ministry of Labour requirements met;
- The humidity level will be controlled to reduce damage to the electrical equipment piping and paint
- Maintenance requirements will be designed into the dry well (i.e. openings to enable the removal of motors/pumps from the station). Lift beam with trolley or simple lift hook shall be provided at a maximum height of 1.2 m above the motors to permit removal;
- Instrumentation and controlling systems must be designed to the satisfaction of the Town;
- Ventilation, heating, and dehumidification equipment shall be provided to protect electrical control equipment from excess moisture;
- A lifting beam complete with a permanently attached trolley or hook shall be provided directly above the pump/motor assembly at a minimum height of 1.2 m above the motors to facilitate removal of the pump motors

6.3.7 Pump Suction Piping

Pump suction lines shall be designed with the following features:

- Inlets consisting of 90o short radius down turned flared elbows;

- Suction velocities for 20-year or greater pumping requirements, preferably in low end of 0.8 m/s to 2 m/s range;
- Flanged wall pipe with water stop collar;
- Ball valve (flanged);
- Flanged eccentric reducer; and
- Minimum pipe size of 100 mm.

6.3.8 Pump Discharge Piping

- Pump discharge piping shall be designed with the following features:
- Velocities for the 20-year or greater sewage flow pumping needs, preferably in the low end of 0.8 to 4 m/s range;
- Flanged, concentric increaser;
- Spacer 150 to 300 mm long with one flanged end and one grooved end for Victaulic coupling;
- Elbows (as necessary);
- Check valve (flanged), preferably horizontally placed;
- Ball valve (flanged);
- Riser pipe; and
- Magnetic or other type of suitable flow meter and recorder (or pump timers for small, constant speed stations where accuracy of flow measurement is not critical – three (3) timers minimum, one (1) for each pump and one (1) for pumps operating in parallel).

6.3.9 Standby Power

The objective of standby power at a sewage pumping station is to allow for emergency operation of the pumping station in order to prevent the discharge of raw or partially treated sewage into any waters, and to protect public health by preventing back-up of sewage and potential discharge into basements, or onto streets and other public and private property.

All sewage pumping stations must provide an automatic generator for standby power in case of power failure. For small pumping stations, a quick connection for a portable generator may be considered by the Town.

Standby generators shall be sized to provide adequate power to start and continuously operate all connected loads including pumps, lighting, ventilation and other auxiliary equipment necessary for the safe and proper operation of the sewage pumping station. The generating

equipment shall be capable of operating all pumps necessary for adequate pumping station operation during emergency situations. The operation of only one pump during auxiliary power supply shall be evaluated and justified on the basis of design peak hourly flows relative to single-pump capacity, anticipated length of power outage, and storage capacity.

Unless the generating equipment has capacity to start all pumps simultaneously with auxiliary equipment operating, special sequencing controls shall be provided to start pump motors.

Where permanent standby generating equipment is provided, the standby generating equipment shall include automatic (i.e. automatic transfer switch (ATS)) and manual start-up and load transfer. Where a connection for portable generating equipment or manual transfer is provided, sufficient storage capacity with alarm system needs to be provided to allow time (minimum two (2) hours) for detection of the pumping station failure and time to transfer, set up, and connect portable equipment.

6.3.10 SCADA/Communications

Supervisory Control and Data Acquisition (SCADA) shall consist of an integrated hardware and software system to provide full control and monitoring of the pumping station. The pumping station must be designed for operation in a manual configuration, and then automated with PLC and SCADA systems. Level control will be a combination of floats and ultrasonic level sensor. Flow monitoring and data logging shall be accomplished with a magnetic flow meter. The selection of all hardware for SCADA and Communications shall be approved by the Town and will be communicated at the pre-design phase. Alarm systems with a backup power source are required for all pumping stations. At a minimum, the following alarms are required:

- Power failure;
- High water level;
- Pump failure;
- Unauthorized entry; and
- Any other case of pump station malfunction.

Pumping station alarms shall include identification of the alarm condition and shall be transmitted to the downstream Wastewater Collection Facility.

6.3.11 Pump Station Water and Facilities

Pumping stations, where possible, shall be serviced and equipped with a minimum 50 mm diameter potable water service equipped with a reduced pressure back flow preventer, isolation ball valve, and either a threaded or cam-lock type house connection, so as to provide suitable

wash down capabilities. Consideration shall be given to providing a washroom and storage facilities on larger pumping stations.

6.4 FORCEMAINS

6.4.1 Minimum Diameter

The minimum diameter of forcemain shall not be less than 75 mm in diameter unless otherwise approved by the Town. The forcemain is to be designed in conjunction with the long range capacity of the pumping station. All future forcemains shall be twinned where crossing under a Provincial highway or rail corridor.

6.4.1.1 Velocity and Transient Analysis

Forcemain velocities shall range from 0.8 m/s to 2.5 m/s. These velocities are sufficient to re-suspend the solids in the forcemains which have settled out when the pumps are not operating. Forcemains shall be designed to the design pressure and must withstand sudden surges in pressure. A transient analysis for all forcemains over 150 mm diameter will be required and must be attached to the design brief.

The use of surge tanks and valves with adjustable rate of closure or other suitable means shall be evaluated.

6.4.1.2 Materials

The pipe material selection is to take into account the design and transient pressures, soil conditions and constructability. Air and vacuum valves to maintain the required flow characteristics and to provide material protection and the need to install in appropriate chambers are to be evaluated.

It is important that forcemains constructed of a similar pipe material to other municipal services be clearly marked and identified in the buried location, with metallic marker tape.

6.4.2 Environmentally Sensitive Areas

In environmentally sensitive locations, preference for a fused pipe material shall be considered.

6.4.3 Emergency Valve Connections

An emergency valve connection shall be installed on all forcemains downstream of the sewage pumping station to allow for the connection of discharge pipes from portable pumps to the forcemain, by-passing the sewage pumping station for either maintenance or emergency purposes.

If the sanitary pumping station is shut down for any reason, there needs to be the ability to allow for connection to emergency pumping. The standard method of emergency connection to a vacuum truck shall include the required isolation valves and quick connection point at or near the pumping station wet well.

6.4.4 Air Release Valves

Low pressure double acting air release valves, or approved equal, shall be installed at high points in the forcemain to prevent air locking. Vacuum relief valves may be necessary to relieve negative pressures on forcemains. The designer shall evaluate the forcemain configuration and head conditions to determine areas where negative pressures will be anticipated, and design for pressure relief.

6.4.5 Drain Valves

If an intermediate high point in the force main lies above the downstream point of the gravity discharge, a partial vacuum condition can be created at the high point, when the force main drains after pumps shut off and when the HGL profile drops below the high point. Drain valves shall be considered at low points in the forcemain profile on a case by case basis (long forcemains, low points along arterial roads or areas that may be difficult to access).

6.4.6 Bedding and Installation

Bedding materials and installation details for forcemains shall conform to current Town Approved Product, Equipment and Suppliers List.

6.4.7 Tracer Wire and Warning Tape

Tracer wire shall be installed on all forcemains for “locate” purposes. Tracer wire shall be brought to the surface in a Test Box using NDS Standard Series Model # WB113BW. The location of the test stations shall be identified on the design drawings. Forcemains installed by trenchless technology in difficult soil condition shall use heavier gage tracer wire or install inside a fused HDPE sleeve.

- Tracing wire shall be T.W.U. (#8-7 multi-strand), number eight gauge, stranded, insulated copper wire with 60 mil of black, cross-linked polyethylene (XLPE) insulation specifically manufactured for direct burial applications.

Tracer wire is to be placed 150 mm (6”) above the pipe (where practical) and installed in such a manner that allows for proper access for connecting of line tracing equipment, proper locating of wire without loss or deterioration of low frequency signal, and without distortion of signal caused by multiple wires being installed in close proximity. Tracer wire shall be brought to the

surface using 50 mm diameter valve boxes spaced at (no greater than) 300 m intervals along the curved sewer for locating purposes. The metallic warning tape shall be laid in the trench 0.3 m (12") to 0.5 m (19") directly above the sanitary main. In addition to tracer wire, metallic warning tape shall be installed over all forcemains.

A continuous length of wire must be used. If the wire must be joined, only the approved connectors shall be used and installed per manufacturer's instructions.

6.4.8 Forcemain Testing

All forcemain integrity is to be evaluated and confirmed with both a pressure and leakage test; flexible pipe material may also be tested with a deflection ball. Isolation valves shall be installed on long forcemains and be placed in conjunction with air or vacuum valves in the same chamber. Consideration of pipe swabbing facilities with mandrel launchers and catchers may be required in special instances.

6.5 EMERGING TECHNOLOGIES

The use of emerging technologies in sanitary sewage collection system design may be considered by the Town on a case by case basis. Some existing emerging technologies that may be considered include the following:

- Water reuse systems;
- New pipe materials;
- New/emerging construction methods; and
- Hydraulic modeling software.

Due to the nature of emerging technologies, there is typically a lack of available monitoring data or design guidelines. As such, it is incumbent upon the proponent or Consulting Engineer to provide complete supporting calculations when submitting sanitary system designs utilizing emerging technologies. A pre-consultation meeting with the Town to discuss the use of emerging technologies is recommended to review the proposed design, and to establish any specific requirements. All submissions employing sanitary collection system design with emerging technologies will be reviewed by the Town and other review agencies on a site-by-site basis.

7 Sanitary Sewers

7.1 GENERAL

In any project where sanitary sewers are required, the sewer system is to be designed to carry the domestic, commercial, and industrial sewage for the area under consideration. Flow is to be by gravity. Low pressure sewer systems will only be considered where other alternatives are not possible and only with written approval from the Town.

If a pumping station concept is approved by the Town, it shall be designed in accordance with the current MECP guidelines and to the satisfaction of the Town.

7.2 CONFIRMATION OF AVAILABLE CAPACITY

Prior to the commencement of any design, the developer and/or designer must contact the Town and confirm that there is adequate capacity to accommodate the proposed project.

7.3 SERVICE AREA

The system shall be designed to accommodate all on site drainage areas as well as all external areas to their maximum future development capacity in accordance with the Town's Official Plan. Sanitary Drainage Plans identifying the internal and external drainage areas will be required.

7.4 DESIGN FLOWS

The use of actual site specific flow data is encouraged. In the absence of flow data, all sewers shall be sized for peak design flows. The design flow in each length of sewer shall be computed on a sanitary sewer design sheet. Calculations shall be based on the following:

$$Q(d) = \frac{PqM}{86.4} + IA$$

Where:

| | | |
|--------|---|--|
| $Q(d)$ | = | Peak domestic flow plus extraneous flows, in L/s |
| P | = | Design population |
| q | = | average daily per capita flow, in L/cap/day |
| M | = | Peaking factor |
| I | = | unit of peak extraneous flow, in L/s/ha |
| A | = | Gross tributary area, in hectares |

7.4.1 Population and Equivalent Population

The estimated populations and development areas shall be in accordance with the Town's Official Plan and Zoning By-Law.

For local sewers, the following population densities are to be used to estimate residential water demands:

Table 6: Population and Equivalent Population

| Unit Type | People/Unit |
|--|-------------------------|
| Single Family | 2.8 |
| Townhouses | 2.8 |
| Apartments | 2.65 |
| Schools | 60 / hectare |
| Light Industrial (No Major Office Component) | 70 / hectare |
| Offices | 150 / hectare |
| Commercial (Retail) | 100 / hectare |
| Heavy Industrial | Use First Principles |
| Mixed Use | 330 ppl/hectare of site |

In the absence of sufficiently detailed development concepts, the following unit densities shall be used, unless otherwise specified in the Official and/or Secondary Plans:

- Single Family and Semi-Detached 24 units per site hectare
- Townhouses 40 units per site hectare
- Apartments 75 units per site hectare

For the design of trunk sewers, population estimates may be based upon census data or other reliable means of estimation.

7.4.2 Sewage Generation Rates

Table 7: Generation Rates

| DEVELOPMENT TYPE | AVERAGE DAILY SEWAGE RATE |
|-------------------------|---|
| Residential | 290 L/capita/day |
| Inflow and Infiltration | 90 L/day/capita |
| Schools | 95 L/student/day |
| Industrial | 9 m ³ /ha/day - from EA (36 m ³ /ha/day - from 1994 MECP) |
| Commercial | 28 m ³ /ha/day |
| Institutional | 28 m ³ /ha/day |

The Town reserves the right to allow or impose alternative standards when there is specific land use and demand information is available.

7.4.3 Peaking Factors

The Harmon formula shall be used to determine the peaking factor (M) to be applied to average daily sewage flows:

$$M = 1 + \frac{14}{4 + \sqrt{p}}$$

where p is the equivalent population of the contribution catchment area expressed in thousands.

The minimum and maximum peaking factors are 2.0 and 4.0, respectively.

Peaking factor for commercial areas - 1.0.

Peaking factor for industrial areas - Appendix "B" of MECP Guidelines.

7.5 PIPE CAPACITY

The capacity of the sewer shall be based on the pipe flowing full. The pipe capacity is to be calculated using Manning's formula and a roughness coefficient of n = 0.013 for concrete and PVC pipes.

7.6 VELOCITIES

The minimum velocity shall be 0.6m/s based on actual flow.

The maximum allowable velocity shall be 3.0 m/s at full flow.

7.7 PIPE SLOPES

The minimum pipe slope shall not be less than 0.5% or that which is required to meet the minimum velocity.

The first upstream leg of sanitary sewer shall have a slope of not less than 1.0%.

The maximum pipe slope shall be that which is required to meet the maximum velocity.

7.8 MINIMUM PIPE SIZE

The minimum pipe size shall be:

- 200 mm for trunk or collector sewers,
- 125 mm or match existing for residential services,
- 150 mm for industrial, commercial or multiple residential services.

Decreases in pipe size from upstream to downstream will not be permitted.

7.9 DEPTH OF COVER

A minimum depth of cover of 2.8 m below the centreline road elevation shall be provided.

Where sufficient cover does not exist, the Town may consider shallower insulated sewers on an individual basis.

The maximum depth of cover is not to exceed applicable OPSD related to the pipe material unless pipe strength design calculations are provided for approval by the Town.

7.10 BEDDING AND BACKFILL

All sanitary sewers are to be installed with minimum 150mm depth of Granular 'A' bedding and 300 mm depth of Granular 'A' cover unless recommended by the Geotechnical Engineer and approved by the Town. Backfill in accordance with OPSD 802.010 or 802.030 to 802.032, as applicable. Compaction is to be a minimum of 95% SPMDD or as indicated in the approved Geotechnical Report. In soft or wet conditions, additional Geotechnical investigation and testing may be necessary to determine the appropriate bedding and backfill measures.

7.11 PIPE CLEARANCES

The minimum horizontal clearances shall be provided in accordance with MECP guidelines. Generally, the watermain shall cross above sewers with sufficient vertical separation to allow for proper bedding and structural support of the watermain, (150mm minimum).

When there is conflict with the elevation of the sewer and the watermain such that the watermain cannot pass over the sewer, then the watermain shall be designed such that it passes under the sewer subject to the following conditions:

- a) There shall be a minimum vertical separation of 0.5m between the bottom of the sewer pipe and the top of the watermain;
- b) The watermain shall be lowered below the sewer using vertical thrust blocks and restraining joints;
- c) The length of the watermain pipe shall be centered at the point of crossing so that the joints are equidistant and as far as possible from the sewer, and;
- d) The sewer shall be adequately supported to prevent joint deflection and settling.

7.12 SEWER MATERIALS

P.V.C. sewers shall be minimum SDR 35 rating.

Concrete sewers shall meet CSA # A257.1/A257.2.

7.13 SEWER LAYOUT

Sanitary sewers shall generally be located as per the typical road cross-sections in [Appendix A](#). Manholes shall be located, whenever possible, with a minimum 1.0 m clearance away from face of curb and/or any other service.

Where sanitary sewers are located in easements, the easement width shall be a minimum of 9.0 m. However, the Town will review alternative easement widths on an individual basis in certain circumstances such as the utilization of a joint trench or installation of a sewer at a depth which is substantially greater than standard.

7.14 MAINTENANCE HOLES

Maintenance holes shall be placed at the end of each line, at changes in size and material, and at abrupt changes in grade and alignment. A maintenance hole will be required on the private property side for sanitary services to commercial, industrial, and institutional properties.

Maintenance hole types and sizes shall conform to all relevant OPSS and OPSD standards and shall be a minimum of 1200 mm. Maintenance hole benching and pipe opening details shall conform to OPSD 701.021.

Obverts of inlet pipes shall not be lower than obverts of outlet pipes.

7.14.1.1 Location and Spacing

The maximum spacing of maintenance holes shall be as follows:

Table 8: Maintenance Hole Spacing

| PIPE SIZE | MAXIMUM SPACING |
|-------------------|---------------------------------|
| 200 mm – 450 mm | 110m |
| > 450 mm – 750 mm | 150 m |
| > 750 mm | Subject to approval by the Town |

7.14.1.2 Head Loss

The obvert of the inlet pipes shall not be lower than the obverts of outlet pipes. The minimum drops across maintenance holes to offset any hydraulic losses shall be as follows:

Table 9: Maintenance Holes

| CHANGE IN DIRECTION | MINIMUM DROP |
|---------------------|--------------|
| Straight run (0°) | 0.03 m |
| 1 – 45° | 0.05 m |
| > 45° | 0.075 m |

The maximum change in direction permitted in a maintenance hole is 90°.

Drops of 0.90 m or greater will require either ‘tee’ or ‘wye’ drop structures (OPSD 1003.010 and OPSD 1003.020, respectively). Internal drop structures are not permitted in municipal systems, although they may be used in private systems.

Note: Internal drop structures may be considered on deep (5 m+) trunk sewers subject to approval by the Town.

7.14.1.3 Frost Straps

Frost straps are to be provided between the upper section through to the base of the maintenance hole section, as per OPSD 701.100. All holes in concrete are to be rotary drilled and sealed watertight using a polyurethane or silicone caulking

7.14.1.4 Maintenance Holes Sealing

Where the high groundwater elevation is above the invert of the sanitary maintenance hole; Blueskin, Mel-rol, Denso or other similar sealants shall be specified to prevent groundwater infiltration.

7.14.1.5 Safety Platform

Safety platforms shall be installed in accordance with OPSD 404.020.

7.14.1.6 Lids and Rims

All maintenance holes located within the traveled portion of the roadway shall have the rim elevation set flush with the surface of the base course asphalt. The concreting and setting of the frame and cover shall be completed in accordance with the details provided in the OPSS and OPSD. A maximum height of 300 mm of modular rings to match final grade shall be permitted. No concrete shall extend over the edge of the maintenance hole.

Prior to placement of the final lift of asphalt, maintenance hole frames shall be reset to final grade.

Where maintenance holes are located in areas to be flooded during the major system design storm, or are otherwise susceptible to inflow of surface water, watertight lids shall be provided as per OPSD 401.050.

7.15 SANITARY SERVICE CONNECTIONS

Single connections for residential and industrial use shall be located in accordance with **Town of Erin Standard Drawings (TOESD) Division 600** for each type of residential lot. All services to be connected to the main with a prefabricated tee. All sanitary service connections shall be single type with min. 125 mm diameter or match existing, with a 125 mm x 100 mm test fitting at property line. Refer to **TOESD 605**.

Connections for commercial, industrial and institutional will be considered on an individual basis but will generally be 150 mm diameter with a maintenance hole just beyond property line.

The minimum slope for all service connections shall be 2.0%.

Tees shall be installed at a 45° angle to the main, where possible, such that the invert of the tee is at the springline of the main.

Service connections should cross under watermains.

Where sanitary main is deeper than 5 m use of sanitary riser is required, maximum height of it should not exceed 5 m.

All floor drains are to be connected to the sanitary service connection. Foundation drains and roof water leaders are not to be connected to the sanitary system.

7.16 STANDARD EASEMENT REQUIREMENTS

Table 10: Sanitary Sewer Easement Standard Specifications

| PIPE DIAMETER | DEPTH OF INVERT (m) | MINIMUM WIDTH OF EASEMENT (m) |
|----------------|---------------------|--------------------------------|
| 250 to 375 mm | 3.0 m maximum | 3.0 metres |
| 450 to 675 mm | 3.0 m maximum | 5 metres |
| 750 to 1500 mm | 3.0 m maximum | 6.0 metres |
| 1650 mm and up | 4.0 m maximum | 4.0 metres + 3 x OD of pipe |

For easements containing more than one pipe or underground service the minimum width will be based on the above chart for the maximum pipe size plus 3.0 metres. Regardless of the preceding, all situations will be reviewed on a case by case basis at the discretion of the Town.

Easements are to be located on one side of the common lot line between adjacent lots to ensure access is only required by one property owner and to ensure perimeter fences are not located along the length of the easement.

7.17 TESTING AND INSPECTION

The following testing requirements apply to all new sanitary sewers. Any sections of sewer or service connections which fail to meet the requirements shall be repaired or replaced at the direction of the Town.

7.17.1 Deflection Testing

All newly installed PVC sanitary sewers shall be subjected to deflection testing in accordance with OPSS 410.

7.17.2 Infiltration/Exfiltration Testing

All newly installed sanitary sewers shall be subjected to infiltration/exfiltration testing in accordance with OPSS 410.

7.17.3 CCTV Inspection

A camera inspection shall be conducted of all sewers and a copy of the video provided to the Town. The sewers shall be video inspected prior to Preliminary Acceptance and again prior to Final Acceptance.

7.17.4 Visual Inspection

All maintenance holes shall be visually inspected by the Town for deficiencies.

8 Storm Drainage and Stormwater Management

Urban development alters the hydrology of the land surface, affecting the quality and quantity of surface runoff. The storm drainage system is to be designed to convey surface runoff from residential, commercial, industrial and roadway areas to an adequate outlet.

Surface runoff is to be conveyed by a dual drainage system (minor/major) comprised typically of an underground storm sewer and a continuous, overland flow route on a roadway surface or open channel.

Ultimately, surface runoff is to be conveyed to natural receiving waters, often following treatment and control through the development of a stormwater management plan to prevent the impairment of water quality and degradation of natural streams, rivers and the ecosystems. The overall purpose of a storm drainage system is to provide a feasible and continuous system to protect property, assets and the environment.

Where development proposals include any sort of alterations to a municipal drain, the laws, regulations and specifications of the Ontario Municipal Drainage Act shall be strictly adhered to and the design specified for the Municipal Drain shall be met.

A majority of the Town is within the jurisdiction of the Grand River Conservation Authority (GRCA), and a small area is within the jurisdiction of Credit Valley Conservation (CVC). The Consulting Engineer responsible for the design of storm drainage systems shall consult both the Town and the governing Conservation Authority to confirm/clarify issues, policies and design requirements.

The purpose of this section is to outline the minimum design requirements for the construction of municipal and private services related to stormwater drainage systems in the Town. These requirements are general in nature and do not relieve the Developer of the responsibility for submitting a completed product demonstrating competent engineering design in full compliance with all applicable legislation.

Any deviation from the minimum Town standards shall be specifically referred to by the applicant and/or his agent with a copy of written approval of the Town attached.

8.1 COMPUTER MODELLING GUIDANCE

The use of the computational model will facilitate the design process to be able to assess various storms of different return periods, durations and distributions to help evaluate the effectiveness of the proposed design. Design modifications and sensitivity analyses can be undertaken easily to better support the proposed methodologies when using a computational model rather than simple hand calculations.

The table below provides a listing of the recommended computer models and typical applications to be used within the Town of Erin.

Table 11: Computer Model Recommendations

| APPLICATION | MODEL RECOMMENDATIONS | ADDITIONAL GUIDANCE |
|---|---|---|
| Hydrology (Single Event) <ul style="list-style-type: none"> Event based hydrologic modeling to establish flow rates and design of peak deduction and attenuation facilities | Visual Otthymo (VO2) SWMMHYMO SWMM MIDUSS | Single event models should utilize intensity-duration-frequency curves as outlined in the section above |
| Hydrology (Single Event) <ul style="list-style-type: none"> Storm Sewer Design | Rational Method | |
| Hydrology (Single Event) <ul style="list-style-type: none"> Storage Facilities | Modified Rational Method | Watersheds < 5 Ha |
| Hydraulics <ul style="list-style-type: none"> To determine flood limits | HEC-RAS | Use CA's established hydraulic models as a base for any watercourse analysis |
| Hydraulics <ul style="list-style-type: none"> Culvert/Bridge Design | HY-8 Mannings, Chezy Equations Culvert Design Sheets | |

Modelling software and approaches not listed here, including spreadsheet models, can be applied, but require additional demonstration of the validity and suitability of the model, and review and confirmation by Town and Conservation Authority staff. Modelling of low impact development applications will require consultation with Town.

8.2 SERVICE AREA

The system shall be designed to accommodate all on-site drainage areas as well as all external tributary areas to their maximum future development capacity in accordance with the Town's Official Plan and Zoning By-Law.

8.3 DESIGN FLOWS

8.3.1 Rational Method

Storm sewers shall be designed to drain all lands less than 5 hectares based on the Rational Method. The Rational Method calculations must be checked using a hydrologic model approved by the Town where the drainage area is greater than 5 hectares. The larger of the flows is to be used in the design of the sewer system unless approved otherwise.

The Rational Method shall be calculated using the following equation:

$$Q = \frac{C i A}{360}$$

where:

- Q = design flow (m³/s)
- c = runoff coefficient (dimensionless)
- i = average rainfall intensity (mm/hr)
- A = drainage area (ha)

8.3.2 Runoff Coefficients

Runoff coefficients are given by components of surface treatment and by land use. The land use values are intended as a guide only and the designer is expected to develop an appropriate coefficient using an arithmetic composite calculation as shown below:

$$C = [(A_1C_1) + (A_2C_2) + \dots] / A_t$$

where: C = composite runoff coefficient (dimensionless)

A_{1,2...} = area corresponding to specific land use or soils type (ha)

C_{1,2...} = runoff coefficient corresponding to A_{1,2...} (dimensionless)

A_t = total drainage area (ha)

Source: adapted from the Ministry of Transportation Drainage Management Manual, 1997, Equation 8.10.

The higher of the arithmetic composite runoff coefficient or the minimum required runoff coefficient by land use, provided in the following table, shall be used to compute design flows.

Runoff Coefficients (Rational C) (5-yr to 10-yr) Based on Hydrologic Soil Group.

Table 12: Runoff Coefficient “C”

| LAND USE | A-AB | B-BC | C-D |
|--|------|------|------|
| Cultivated Land, 0 - 5% grade | 0.22 | 0.35 | 0.55 |
| Cultivated Land, 5 - 10% grade | 0.30 | 0.45 | 0.60 |
| Cultivated Land, 10 - 30% grade | 0.40 | 0.65 | 0.70 |
| Pasture Land, 0 - 5% grade | 0.10 | 0.28 | 0.40 |
| Pasture Land, 5 - 10% grade | 0.15 | 0.35 | 0.45 |
| Pasture Land, 10 - 30% grade | 0.22 | 0.40 | 0.55 |
| Woodlot or Cutover, 0 - 5% grade | 0.1 | 0.25 | 0.35 |
| Woodlot or Cutover, 5 - 10% grade | 0.15 | 0.30 | 0.42 |
| Woodlot or Cutover, 10 - 30% grade | 0.18 | 0.35 | .52 |
| Lakes and Wetlands | 0.05 | 0.05 | 0.05 |
| Impervious Area (i.e., buildings, roads, parking lots, etc.) | 0.95 | 0.95 | 0.95 |
| Gravel | 0.4 | 0.5 | 0.6 |
| Unimproved Areas | 0.1 | 0.2 | 0.3 |
| Lawn, < 2% grade | 0.05 | 0.11 | 0.17 |
| Lawn, 2 - 7% grade | 0.10 | 0.16 | 0.22 |
| Lawn, > 7% grade | 0.15 | 0.25 | 0.35 |

| LAND USE | Minimum Coefficient |
|---------------------------|---------------------|
| Parks | 0.20 - 0.35 |
| Single Family Residential | 0.40 - 0.50 |
| Semi-Detached Residential | 0.50 - 0.60 |

| LAND USE | A-AB | B-BC | C-D |
|-----------------------------|------|-------------|-----|
| Multiple Family Residential | | 0.55 - 0.75 | |
| Apartments and Industrial | | 0.75 - 0.80 | |
| Central Business District | | 0.90 - 0.95 | |
| Paved Areas | | 0.95 | |

Run-off Coefficients shall be determined from the types of land uses within the drainage area.

The run-off coefficient values provided above are recommended minimum values; however, the Developer's Engineer should determine the appropriate coefficient of imperviousness based on the actual uses.

Adapted from Design Chart 1.07, Ontario Ministry of Transportation, "MTO Drainage Management Manual," MTO. (1997).

Note: gravel parking or storage areas for new development should be considered as paved areas as they may be paved in the future.

Runoff coefficients (Rational C) for development such as single family, semi-detached, Duplex, Town housing, Commercial, Industrial, Institutional, Schools, Churches, and Park etc. shall be calculated using a weighted average of the runoff coefficients for the relative areas using the coefficients outlined in the table.

On a project specific basis, a detailed calculation of the run-off coefficient may be requested by the Town.

The runoff coefficient shall be adjusted for return period events greater than the 10-yr storm as follows:

A minimum run-off coefficient of 0.55 is to be used for undeveloped upstream areas where future residential development is expected and 0.75, where future industrial, high-density residential or commercial development is expected.

For estimating peak flows for events larger than the 1:10-year design storm, the runoff coefficient shall be adjusted based on the following expressions, up to a maximum of 0.95:

$$C_{25} = 1.10 \times C_5$$

$$C_{25} = 1.20 \times C_5$$

$$C_{25} = 1.25 \times C_5$$

Note: When applying the runoff coefficient adjustment, the maximum c-value should not exceed 1.0.

8.3.3 Rainfall Data

The rainfall intensity is to be determined from the Intensity-Duration-Frequency (IDF) curve information in the Table below.

Table 13: IDF Equation Constants

| Return Period | IDF Equation Constants | |
|---------------|------------------------|--------|
| | A | B |
| 1:2-Year | 22.8 | -0.699 |
| 1:5-Year | 30.1 | -0.699 |
| 1:10-Year | 35.0 | -0.699 |
| 1:25-Year | 41.0 | -0.699 |
| 1:50-Year | 45.5 | -0.699 |
| 1:100-Year | 50.0 | -0.699 |

The average rainfall intensity shall be calculated using the following equation:

$$I = A x t^B$$

Where

- I = rainfall intensity (mm/hr)
- A, B = IDF equation constants (dimensionless)
- T_c = time of concentration (minutes)

8.3.4 Climate Change Considerations

In the Spring of 2020, the provincial government released an update on the Provincial Policy Statement (PPS 2020). There is growing concern about the potential impacts of climate change on our municipal infrastructure. In recent years, in Southern Ontario, severe, intense storms have caused widespread flooding with thousands of flooded basements, broken trunk sewers, washed-out roads, resulting in damages estimated at hundreds of millions of dollars.

There is emerging guidance on the development and use future Intensity Duration Frequency (IDF) statistics to account for the expected change in climate; however, there is also a lack of consensus on the most appropriate methods. The Province of Ontario set up a committee in 2008 led by the Ministry of Environment (now MECP) to review stormwater management in light of climate change. The objective is to make recommendations on whether legislation, or regulations or policies need to be written to regulate SWM practices to account for climate change. Some changes could also be made to the MECP SWM manual as a result of this review. This work is ongoing. When changes are made to provincial guidance, then the Town standards can be updated accordingly.

A study of the comparison of future Intensity-Duration-Frequency (IDF) Curves based on downscaling global climate change models was led by TRCA and ERCA and released in 2016 as an addendum to an earlier paper. This 2016 paper acknowledged the complexity of this issue and eventually recommended that future research needs to be conducted as a variety of solutions may be available (<https://climateconnections.ca/app/uploads/2014/01/IDF-Comparison-Report-and-Addendum.pdf>).

Until there is further direction from the Province, LTC recommends using the Ministry of Transportation Intensity Duration and Frequency (IDF) curves to address climate change impact. These can be accessed on the website: http://www.mto.gov.on.ca/IDF_Curves/terms.shtml. This tool has been developed to provide geographically distributed IDF curves in a gridded form based on Environment Canada and National Oceanic and Atmospheric Administration (NOAA) precipitation data.

The Town recommends that initial analyses be completed with the base 2010 year IDF curves for both existing and proposed conditions. Then a 50-year range for the IDF Curve be selected to conduct the hydrologic analysis to incorporate climate change impacts into the proposed design.

This additional analysis should be used to assess whether any adjustments are required for the minor and major drainages systems and storage portions of the stormwater management facilities to account for climate change considerations.

For example, if the analysis was completed in 2020, both the 2010 reference and 2070 IDF curves should be used for the hydrologic analysis. A comparison of the 2010 vs 2070 results should be reviewed to see if any changes to the design need to be incorporated for potential climate change impacts. Copies of the design IDF Curve data from the MTO website should be included in the Stormwater Management Report or Brief. Both the baseline (2010) IDF data and the future IDF data will be included in the report.

Other methods to address climate change may be entertained if defensible reasons are provided and the municipality is in agreement. The method of addressing climate change should be discussed during the Pre-Consultation for the proposed development. If the Province eventually provides direction on addressing climate change with respect to stormwater submissions, this document will be updated to reflect the direction from the Province.

8.3.5 Storm Distributions

Hydrologic simulation models may be used to simulate a single storm event or a continuous period of rainfall data. For SWM design, models that use a single storm event are frequently used. The rainfall input for the model would be a hyetograph. The hyetograph may have been obtained as a historical record for that location through a rain gauge. For example, The Timmins Storm is a historic storm used in parts of Southern and Central Ontario for flood control design. It is also known as the Regional Storm.

Synthetic design storms are also constructed using established distributions and historical rainfall amounts. There are two methods generally used to derive synthetic design storms. One method develops the storm hyetograph from the IDF curve.

Examples are the Uniform design storm and the Chicago design storm (Keifer & Chu, 1957). The second method develops the design storm from an analysis of historic storm events. Examples are the U.S. Soil Conservation Service (SCS) design storm, the Illinois State Water Survey design storm, and the Atmospheric Environment Service (AES) design storm.

The following design storms are recommended to be used for modeling:

- 1 hour and 4 hour Chicago distribution;
- 6 hour and 12 hour AES Southern Ontario 30% distribution;
- 12 hour and 24 hour SCS Type II distribution;
- Regional Storm event (Timmins 12 hr event);
- Sub-watershed / watershed / master drainage plan storm distributions (if applicable);

The 4 hour Chicago storm hyetograph is widely used in Southern Ontario and has a sharp peak. Research at the University of Ottawa showed that the Chicago design storm gave peak flow predictions close to the flows from historic storm events for urban watersheds. It is recommended that the time step should be 10 minutes maximum.

The U.S. Soil Conservation Service (SCS) developed the Type I and Type II design storms which are two rainfall distributions for two different areas of North America. The Type II distribution applies to most parts of Canada. The distribution is a mass curve for percent of accumulated rainfall depth over a duration of 24 hours. First, a duration and a return period are selected. Then

the corresponding volume is obtained from the IDF curve. The volume is then distributed over the steepest portion of the SCS 24- hour curve. The 12 hour SCS storm is derived from the steepest 12 hours of the 24 hour SCS curve. The SCS Type II Distribution is shown in the MTO Drainage Design Manual, Design Chart 1.05.

Hydrologic modeling must follow Watershed Plan recommendations, if available, when selecting storm distributions. The distributions selected in the Watershed Plan model should be used for modeling site developments. Rainfall amounts should be based on the intensity-duration-frequency (IDF) curves from the MTO website as discussed earlier.

8.3.6 Time of Concentration

The time of concentration is to be calculated as the sum of the initial inlet and the travel time in the pipe, where the initial inlet time is to be ten (10) minutes for the five (5) or ten (10) year storm.

This shall apply where the upstream drainage area does not include large open space areas. Where peak flows from external areas enter a subdivision sewer system, the more critical case based on either the time of concentration including the external area or the time of concentration excluding the external area shall be used. Actual velocities of computed peak flows shall be used to estimate time of concentration.

A design evaluation of inlet times must be submitted to justify inlet times different from those specified above.

To calculate the initial time of concentration for upstream, undeveloped lands, the Bransby-Williams, or Airport formulas may be used.

8.4 MINOR DRAINAGE SYSTEM

Storm drainage shall be accommodated by a system of curb and gutters along with storm sewers, with the exception of rural roadways or estate residential subdivisions, where an open ditch system may be permitted if minimum design criteria can be realized.

Underground storm sewers are to be designed to convey a minimum of the 1:5-year storm without surcharge. However, when the major storm drainage system is inadequate, the Town may consider the approval of an underground storm sewer system designed to carry additional flows.

8.5 STORM SEWER DESIGN

8.5.1 Pipe Capacity

The hydraulic capacity of sewers shall be based on Manning's formula (for pipes flowing full):

$$Q = \frac{1}{n} \times A \times R^{\frac{2}{3}} \times S^{\frac{1}{2}}$$

Where

- Q = capacity of the pipe (m³/s)
- n = Manning's roughness coefficient (dimensionless)
- A = cross sectional area of the conduit (m²)
- R = hydraulic Radius of the conduit (m)
- S = slope of the pipe (m/m)

For circular pipes flowing full, Manning's formula can be expressed as follows:

$$Q = \frac{\pi}{n} \times \frac{D^{\frac{8}{3}}}{4^{\frac{3}{5}}} \times S^{\frac{1}{2}}$$

Where

- Q = capacity of the pipe (m³/s)
- n = manning's roughness coefficient (dimensionless)
- D = nominal diameter of the pipe (m)
- S = slope of the pipe (m/m)

Appropriate values of Manning's roughness coefficient (n) used in the Manning's formula are summarized in the table below:

Table 14: Manning's Roughness Coefficients for Pipes

| TYPE OF PIPE | ROUGHNESS COEFFICIENT |
|------------------|-----------------------|
| Concrete | 0.013 |
| PVC | 0.013 |
| Profile Rib Pipe | 0.013 |
| HDPE | 0.021 |

The minimum storm sewer diameters in residential areas shall be 300 mm. The minimum storm sewer diameters in industrial and commercial areas shall be 375 mm.

8.5.2 Velocities

The minimum allowable actual velocity in a storm sewer shall be 0.75 m/s.

The maximum allowable actual velocity shall be 4.5 m/s.

8.5.3 Minimum and Maximum Pipe Slopes

The minimum pipe slope shall be that which is required to meet the minimum velocity, but shall not be less than 0.3%.

The maximum pipe slope shall be that which is required to meet the required capacity and maximum velocity.

8.5.4 Minimum Pipe Sizes

The minimum pipe size is 250 mm for single catchbasin leads and 300 mm for double catchbasin and rear yard catchbasin leads.

The minimum pipe size is 300 mm for mainline storm sewers.

The minimum pipe size is 675 mm for radius pipe.

8.5.5 Minimum Depth of Cover

The minimum depth of cover to be provided shall be the greater of:

- a) 1.5 m below the centreline of road or finished ground surface elevation to the spring line of the sewer; or
- b) 1.2 m to the obvert of the sewer, provided that there are no conflicts with utility crossings.

Where sufficient cover does not exist, the Town may consider shallower insulated sewers on an individual basis.

The maximum height of fill is not to exceed applicable OPSD (805.010 through 807.050) unless pipe strength design calculations are provided for approval by the Town.

Bedding and Backfill

In general, all storm sewers are to be installed with minimum 150 mm depth of Granular "A" for bedding, and with minimum 300 mm depth of Granular "A" for cover. For concrete pipes, cover can be of minimum 300 mm depth of sand. Depending on the soils and pipe strength calculations, bedding types that differ from the above as recommended by the Geotechnical Engineer may be approved by the Town. Trench backfill will be in accordance with OPSD 802.010 or 802.030 to 802.032 as applicable. Compaction is to be a minimum of 95% SPMDD or as indicated in the approved Geotechnical Report.

8.5.6 Pipe Clearances

Minimum horizontal clearance between the outside wall of the adjacent sewer pipes (sanitary, or second storm) shall be 900mm. A minimum clearance of 500mm between the obvert of the sanitary sewer and invert of the storm sewer shall be provided if the sanitary connections are required to go under the storm sewer. Other minimum clearances shall be provided in accordance with MECP Procedure F-6-1.

8.5.7 Sewer Layout

Storm sewers shall generally be located as per the typical road cross-sections standard drawings. Where storm sewers are located in easements, the easement width shall be a minimum of 9.0 m. However, the Town will review alternative easement widths on an individual basis in certain circumstances such as the utilization of a joint trench or installation of a sewer at a depth which is substantially greater than standard. Where there is a rear yard catchbasin there is to be a minimum width of 3.0 m easement. Easements for rear yard catchbasins are to be located within the boundaries of one lot and shall not straddle lot lines.

8.5.8 Maintenance Holes

Maintenance holes shall be as per applicable OPSD 701 series and shall be placed at the beginning and end of each sewer line, at changes in pipe size and/or material, and at changes in grade and/or alignment. For pipe diameter greater than 900 mm, curved (radius pipe) or properly deflected sewer lines on may be permitted with written approval from the Town. Maintenance holes shall not be located in the curb line.

All maintenance holes shall be pre-benched up to springline.

The desirable maximum spacing between maintenance holes shall be 90 m. For pipe diameter greater than 900 mm, maximum spacing of 120 m may be allowed upon consultation with the Town.

The maximum change in direction is 90° for pipes 750mm and larger, and 45° for pipes over 900 mm diameter.

A sufficient drop shall be provided across each maintenance hole to offset any hydraulic losses. The drop shall be determined by hydraulic calculations for all junction and transition maintenance holes. The minimum drops across a maintenance hole shall be as follows:

Table 15: Minimum Maintenance Hole Structure Drops

| CHANGE IN DIRECTION | m |
|---------------------|--------|
| Straight run (0°) | 0.02 m |
| 1 - 45° | 0.05 m |
| 45° - 90° | 0.08 m |

Precast concrete adjustment units shall be used for maintenance hole adjustments. No brick, block or steel lift rings shall be permitted. When adjusting the top elevation of maintenance holes, a minimum of one to a maximum of three adjustment units shall be installed on the top of the structure. The minimum vertical adjustment of maintenance holes via Moduloc shall be 50 mm. The maximum vertical adjustment of maintenance holes via Moduloc shall not exceed 300 mm. Any adjustment exceeding this amount shall consist of precast concrete riser sections.

Drop structures shall be provided when the difference in the inlet and outlet inverts is equal to or greater than 0.9 m that cannot be eliminated by changing sewer grades. Use of an internal drop structure is not permitted for new manholes.

Safety platforms shall be installed in accordance with OPSD 404.020 for all maintenance hole depths of 5.0 m or greater.

Obverts of inlet pipes shall not be lower than obverts of outlet pipes. Springline connection principle for the inlet and outlet pipes requires a written approval from the Town.

Where maintenance holes are located in areas to be flooded by the major storm maintenance hole covers shall be of the sealed variety. In all other areas, standard maintenance hole covers shall be used.

Frost straps to be installed as per OPSD 701.100.

Decreases in pipe size from upstream to downstream will not be permitted.

8.5.9 Catchbasins

Catchbasins shall be located upstream of pedestrian crossings and not within 1.0 m of any curb depressions. Preferably, catchbasins will be installed on projections of lot lines. Catchbasins or catchbasin manholes are not to be located at driveways. Double catchbasins shall be located where flows are being received from more than one direction, such as at low points. Double catchbasins are not to be located on horizontal curves.

The maximum allowable spacing shall be in accordance with the following:

Table 16: Catchbasin Structure Spacing

| ROAD GRADE | MAXIMUM SPACING (m) |
|------------|---------------------|
| 0.5-3.0% | 105 m |
| 3.0-4.5% | 90 m |
| >4.5% | 75 m |

Closer spacing may be required on arterial roads or in densely built areas. Catchbasin capacities shall be determined in conjunction with the overall stormwater management system. On roadways, catchbasins shall have a minimum capacity to capture the runoff from the 5 or 10-year design return frequency storm. Where the pipe system is designed to convey flows in excess of the design frequency storm, sufficient catchbasin capacity shall be provided to permit the design flows to enter the sewer system. Inlet control devices may be used where the hydraulic grade line needs to be strictly controlled to prevent surcharging of the sewer line and to allow storm sewer house connections.

Where catchbasins are used as inlet controls, spacing shall be determined by design and must be approved by Town.

Depressing catchbasins below the normal gutter grade, or constructing asphalt basins around catchbasins will not be permitted by the Town. All catchbasin frames and grates are to be set squarely on the structure. Overhang of the frame into the roadway or boulevard will not be permitted. Should overhang of the frame occur, the catchbasin shall be reset to the correct alignment. When adjusting the top elevation of catchbasins, a minimum of one to a maximum of three (3) adjustment units shall be installed on the top of the structure. The maximum vertical adjustment shall not exceed 300 mm. Any adjustment exceeding this amount shall consist of precast concrete riser sections.

Catchbasin leads shall be minimum 250 mm at 1.0% grade for single catchbasins, and 300 mm at 1.5% or 375 mm at 1.0% grade for double catchbasins.

Catchbasin leads shall connect to maintenance holes where possible. Prefabricated tee shall be used when catchbasin leads are connected to the sewer run. All catchbasin leads shall have a minimum depth of cover of 1.2 m to the obvert.

Use of rear lot catchbasins shall be discouraged and overland swales draining to the roadway are to be used wherever possible. All rear yard catchbasin connections are to be encased in concrete where they are adjacent to the building envelope.

Catchbasin Sump shall be 0.60 m deep for single catchbasins (0.60 x 0.60 m), and 0.30 m deep for double catchbasins (0.60 m x 1.45 m) and catchbasin maintenance holes.

All catchbasin weepholes, lift holes and unused subdrain knockouts are to be plugged with mortar.

8.5.10 Foundation Drainage System

In order to minimize the flow rate from foundation drains, a minimum distance of 0.5 m shall be provided between the underside of the basement floor slab and the measured seasonal high groundwater table. Other methods of controlling foundation drain flow rate will be considered in consultation with Town.

8.5.11 Storm Service Connections

Single connections for residential lots shall be constructed in accordance with **TOESD division 600** for each type of residential lot. Connections for commercial, institutional or multiple use will be considered on an individual basis.

The minimum depth of cover is 1.5 m and the minimum slope is 2.0%.

Roof leaders shall not be connected to the storm sewer system. Roof leaders are to be discharged to the ground surface onto splash blocks or extended by a minimum of 450mm outwards, and flows shall be directed away from the building in such a way as to prevent ponding or seepage into the foundation weeping tile.

8.5.12 Testing

The following testing requirements apply to all new storm sewers. Any sections of sewer or service connections which fail to meet the requirements shall be repaired or replaced at the direction of the Town.

Deflection Testing

All newly installed PVC and Polyethylene storm sewers shall be subjected to deflection testing in accordance with OPSS 410.

Deflection testing is not required for concrete storm sewers.

Infiltration/Exfiltration Testing

Infiltration or exfiltration tests will be required in accordance with current O.P.S. and MECP standards if so requested by the Town.

CCTV Inspection

CCTV Inspection will be required prior to Preliminary Acceptance and again prior to Final Acceptance.

Visual Inspection

All maintenance holes and catchbasins shall be visually inspected by the Town for deficiencies prior to Preliminary Acceptance and again prior to Final Acceptance.

8.5.13 Subdrain

Subdrain shall be continuous 100 mm dia. geotextile wrapped subdrain. Subdrain shall generally be located as per the typical road cross-sections standard drawings.

8.5.14 Pipe Materials

The following are lists of materials pre-approved by the Town. Other materials may be accepted by the Town upon formal request with supporting pipe specification documents required by Town.

Pipe size of 375 mm Diameter or less:

- P.V.C. SDR 35
- IPEX Ultra Rib
- Loc Pipe ALoc P.V.C.@
- Concrete - CSA A257.1 (Non-reinforced)
- CSA 257.2 (Reinforced)
- HDPE Boss 2000, 320 Kpa Stiffness c/w Ultra Stab 75 Joint
- Royal Rib "Koriflo"

Pipe size of 450 mm Diameter or greater

- Concrete - CSA 257.1 (Non-reinforced)
- CSA 257.2 (Reinforced)

8.6 MAJOR DRAINAGE SYSTEM

The major system shall be designed to safely convey flow in excess of the minor system including the larger of the 100-yr storm and Hurricane Hazel via streets, open channels, storm sewers, walkways, and approved drainage easements to a safe outlet without flooding private property. The combination of the overland flow system and the minor system shall be designed to prevent

flooding of private property with maximum level of road flooding and surface detention as defined in the table below.

It shall also be demonstrated that overland flow conditions resulting from the 100-year/Hazel storm will not cause unacceptable flooding damage to private property with a maximum level of road flooding and surface detention as outlined in the table below.

Table 17: Maximum Allowable Flow Depths

| LOCATION | STORM RETURN FREQUENCY (YEARS) | | |
|--------------------------|--------------------------------|---------------------------|------------------------------------|
| | 5 | 25 | 100/Hazel |
| Walkways | minor surface | as required | as required |
| Open Spaces | up to 25 mm | for overland flow outlets | for overland flow outlets |
| Local Roads | No ponding | 0.05m above crown | 0.15m above crown |
| Collector and Industrial | 0.10 m deep at low point | up to crown | 0.10 m above crown |
| Arterial Roads | 0.10m deep at low point | 1 lane clear | up to crown maximum depth of 0.3 m |

In new subdivisions the limit of overland flow route floodlines for the 100 year/Hazel storm event shall not extend onto private property unless protected by a drainage easement. Development of the site must not increase flood levels upstream or downstream of the development.

For all classes of road, the product of depth of flow at the gutter (m) times the flow velocity (m/sec) shall not exceed 0.65 m²/sec.

Street grading must provide a continuous gradient to direct street flows to a safe outlet at low points. Outlets can be walkways or open sections of roadways leading to parks, open spaces or river valleys.

Pre-development peak flows shall be computed by an approved hydrologic model. Watershed definition and pre-development flows must be approved by the Town.

Preliminary estimates of post-development flow rates may be computed using the Rational Method. For all systems and for the design of surcharged sewers and detention facilities, computer modeling shall be undertaken.

8.6.1 Open Ditches

In rural areas, industrial areas, or estate residential subdivisions, open ditches may be permitted by the Town. Ditches shall be constructed a maximum of 0.5 m and a minimum of 0.15 m below the sub-grade of the roadway. Where this cannot be achieved, a sub-drain may be provided under the invert of the ditch and day-lighted once the minimum depth can be attained.

The minimum ditch grade shall be 0.5% and the maximum 5%. In exceptional cases and where ditches are on easements, ditches with grades greater than 5% may be allowed, provided sufficient erosion protection provided to the satisfaction of the Town. Where ditch grades exceed 5%, the Town may require that an urban cross-section be applied for that road segment.

The minimum ditch protection on all ditches shall be 300 mm of topsoil and staked sod on the side slopes and bottom of the ditch.

8.6.2 Open Channels

Open channels are to be utilized in the following circumstances:

- a) For the Regional Storm where the upstream watershed area exceeds 1 square kilometre (100 ha);
- b) For a minimum 25-year return frequency storm with protection from erosion damage for larger storms if required by the Town;
- c) To maintain the natural storage characteristics of the watercourse;
- d) To maintain a natural appearance as far as possible; and
- e) To meet specific requirements of the Conservation Authority.

8.6.3 Sufficient Outlet

All developments must demonstrate that the stormwater generated onsite is directed to a sufficient outlet.

A sufficient outlet typically constitutes a lake or permanently flowing watercourse. Sufficient outlet may also include public right-of-ways provided that written permission is obtained from the Town. In the case where the discharge is directed over private land, the developer must obtain a legal right of discharge registered on title. Copies of all written documentation such as a legal right of discharge registered on title and/or written permissions from the Town must accompany the design submission.

The designer shall provide calculations for the conveyance capacity of the downstream conveyance routes to demonstrate that upstream, downstream and adjacent landowners do not

incur adverse impacts, including increased runoff volumes, and that the flow is conveyed in a safe manner.

8.7 STORMWATER MANAGEMENT

The principles and design criteria in this section are intended to augment the guidelines, policies, and standards established in the latest version of the Ministry of Transportation (MTO) Drainage Management Manual, the MTO Highway Drainage Design Standards, the Ministry of the Environment, Conservation and Parks (MECP) Stormwater Management Planning and Design Manual, the MECP Draft Low Impact Development (LID) Stormwater Management Guidance Manual, April 2017, The Grand River Conservation Authority “Design Principles of Stormwater Management Facilities”, Credit River Watershed “CVC Stormwater Management Guidelines, August 2012” and “CVC Stormwater Management Pond Planting Guidelines, July 2014”.

Where the Town’s Development Engineering Standards Manual does not provide specific details, all designs should stay in conformity with the most current version of the above listed documents.

In the planning and design of stormwater management facilities, the designer is to have full regard for the riparian rights of all surrounding, upstream and downstream landowners. Consideration of the surrounding topography, land uses, and environment and integration of the facility into such elements is paramount. Opportunities for linking these facilities with trail systems should be maximized.

8.8 LOW IMPACT DEVELOPMENT

The Town encourages the implementation of low impact development (LID) measures to minimize post development runoff volumes and maintain existing hydrological conditions within new developments. The Town requires the stormwater management design of new and infill developments, as well as reconstruction and retrofit projects, to promote at-source control of post development runoff, thereby reducing the dependence on end-of-pipe controls where site conditions permit. The “Low Impact Development Stormwater Management Planning and Design Guide” developed by Credit Valley Conservation Authority (CVCA), the MECP Draft Low Impact Development (LID) Stormwater Management Guidance Manual, April 2017, and Toronto and Region Conservation Authority (TRCA) will be a general guide for the LID measures. The Town will assess each development on a case by case basis.

To assess the applicability of incorporating LID’s as part of the stormwater management design, a comprehensive report prepared by a qualified engineer will be required for each project, which must include the following information:

- a) Describe existing site conditions, including significant environmental features as well as soil type, infiltration capacity, and depth to water table;

- b) Depending on the extent of the proposed project, prepare maps identifying the environmental features, soil conditions, and water table depth to show all aspects under consideration in the environmental design of the stormwater management system for the development;
- c) Complete single event and continuous (if required) simulation rainfall/runoff event models to establish the baseline quality and quantity of stormwater runoff originating from the development area under existing conditions as a framework for evaluating combinations of LID components with conventional end-of-pipe controls;
- d) Prepare an assessment of the various combinations and sizing requirements of LID components and end-of pipe controls based on their suitability for achieving the stormwater management control targets under typical post development conditions;
- e) Select a preferred alternative for achieving stormwater management control targets for consideration by the Town.

The implementation of any design that employs the use of Low Impact Development practices will be subject to Town and Conservation Authority Approval.

8.9 NUTRIENT MANAGEMENT STRATEGY AND WATER BALANCE

The Town supports the reduction of phosphorous contributions from development into the streams and lakes of the watershed within the Town. To achieve this goal, the Town encourages that effective measures be taken to mitigate and reduce phosphorous contributions from new developments wherever possible.

The Town also recognizes that reduced groundwater recharge due to new development can impact stream baseflows.

As such, the Town require that stormwater management design for new developments incorporate the most recent advances in phosphorus reduction and water balance technologies or strategies within the development proposal as per the most recent guidelines and standards as set out by the MECP and relevant Conservation Authority.

8.10 STORMWATER MANAGEMENT FACILITIES

All stormwater management facilities are to be designed to control post-development runoff flows to pre-development levels for rainfall events with return periods between 5 and 100 years. Overcontrol may be required to satisfy downstream constraints. All new stormwater management facilities are required to provide an Enhanced level of water quality protection.

All stormwater management facilities are to be designed in accordance with the most current MECP “Stormwater Management Planning and Design Manual”.

The information provided below is intended to supplement the aforementioned manual and requirements.

8.10.1 Stormwater Quantity and Quality Controls

Current stormwater management practice advocates the consideration of Stormwater Management Practices (SWMP's) on a hierarchical basis, whereby more pro-active techniques are considered first. The SWMP's are grouped under the following headings in order of preferred application:

- Lot Level Techniques and Source Controls
- Transport or Conveyance Controls
- End-of-Pipe Controls

The philosophy behind this hierarchy is that stormwater management techniques are usually more effective when applied at the source. Development can result in negative impacts to the hydrologic cycle elements of evaporation, infiltration, soil storage, and runoff as well as runoff water quality and erosion of local water courses and water bodies. Low Impact Development (LID) measures and Storm Water Management (SWM) measures can help reduce the impacts of development by increasing infiltration, evaporation, soil storage, water reuse, and reducing runoff, detrimental water quality impacts, and downstream erosion.

The “Low Impact Development Stormwater Management Planning and Design Guide” (Latest version) developed by CVC/TRCA is a comprehensive guideline that provides guidance on planning, site selection, design, construction, and operations and maintenance of LIDs. This guidance document, commonly referred to as the “LID Guide”, should be used to select, design, and maintain LID practices.

The Town supports the progressive implementation of a wide range of stormwater management techniques. This range is expected to increase and change over time, as longterm monitoring results indicating the level of success of various techniques become available. The Town also supports the integration of stormwater management facilities with passive recreational opportunities, where the intended function of either is not impaired.

The following table provides the current perspective of the Town regarding available stormwater management practices, as well as special supporting documentation which is required for implementation of each technique.

Proponents must contact the Town prior to submitting formal applications to discuss specific LID and SWM objectives for each project. In the absence of specific design criteria, proponents must utilize the following criteria for development projects:

Table 18: Stormwater Management Techniques

| STORMWATER MANAGEMENT TECHNIQUE | TOWN'S PERSPECTIVE | SUPPORTING DOCUMENTATION |
|---------------------------------|-----------------------------|--|
| Rainwater harvesting | Encouraged | On private property |
| Green roofs | case-by-case basis | Requires Town acceptance |
| Roof Downspout Disconnection | Encouraged | Direct flow towards a splash pad |
| Soakaway, infiltration trench | Encouraged | On site 5 m from buildings, clean or pretreated runoff |
| Bioretention | Encouraged for clean source | Requires Town acceptance on municipal lands |
| Vegetated filter strips | Encouraged | On private property |
| Permeable pavement | Encouraged | On private property |
| Enhanced grass swales | Encouraged | On private property or Requires Town Acceptance |
| Dry swales | Encouraged | On private property or Requires Town Acceptance |
| Perforated pipe systems | case-by-case basis | Requires Town acceptance |
| Parking lot storage | case-by-case basis | Requires Town acceptance |
| Oversized pipes | Encouraged | On private property |
| Wet ponds | Encouraged | SWM Report |
| Wetland ponds | Encouraged | SWM Report |
| Hybrid ponds | Encouraged | SWM Report |
| Dry ponds | Encouraged | SWM Report |
| Oil/grit separators | Encouraged | Drainage areas <5 ha |
| Infiltration basin | case-by-case basis | Requires Town acceptance |

Note: Several criteria are inter-related, for example retaining the first 5 mm of precipitation on-site not only produces water balance benefits, it also provides runoff water quantity reduction, water quality improvements, and downstream erosion benefits.

Application of in-ground LID measures has to be evaluated taking into consideration the ground water levels observed in the project area.

8.10.2 Emergency Spillway

All stormwater management facilities shall be designed with an emergency spillway to allow drainage to safely exit the facility should the outfall structure fail to function, or should the storm event have a frequency lower than the 100-year storm. The emergency spillway shall be designed to convey the Regional Storm event post development routed peak flow with the invert of the spillway set, as a minimum, at the 100-year controlled water level (or Regional controlled water level for ponds where Regional control may be required). A freeboard of 0.30 m shall be provided above the maximum routed Regional Storm water level to the top of the pond berm.

The emergency spillway shall incorporate erosion protection measures that are adequately designed to withstand the erosive velocity associated with the uncontrolled governing flow. The erosion protection shall be integrated with a natural vegetated surface treatment that is aesthetically pleasing.

Spillway side slopes shall not be steeper than 3:1 and shall be no steeper than 10% when incorporated into the access road. The spillway shall not be located directly above the outlet control structure and a minimum horizontal clearance of 3.0 m shall be provided.

8.10.3 SWM Facilities Grading (Side Slopes)

Grading within stormwater management facilities shall be designed with the minimum slope as follows:

- Stormwater management facilities shall be designed with slopes no steeper than 3:1 (H:V).
- Stormwater management facilities in residential areas shall be designed with slopes no steeper than 5:1 (H:V) to avoid fencing. Fencing shall be required where the facility abuts private lands.
- Storm water management areas that are not within a residential development and with slopes steeper than 5:1 (H:V) will be fenced entirely.
- Retaining walls will not be permitted in the design of stormwater management facilities.

8.10.4 Major System Overland Flow Routes

The major system overland flow route to the SWM facilities shall be designed to safely convey the Regulatory (i.e. the larger of the 100-yr storm and Hurricane Hazel Storm) overland flow. Should the overland flow route to the SWM facility consist of the access road and path, then the flow depth shall not exceed 300 mm or a velocity of 0.65 m/s. Where feasible, the overland flow should not be directed into the forebay to avoid the re-suspension of settled sediments.

8.10.5 Anti-seepage Collars

Anti-seepage collars shall be installed on all outlet pipes or as directed by a geotechnical engineer.

8.10.6 Existing Groundwater Elevation

At least one borehole shall be located near the center of the SWM block as part of the geotechnical investigation, to assess the nature of existing soils and the groundwater elevation. The groundwater elevation shall be compared to the proposed permanent pool water elevation within the facility. Where soil conditions are very permeable and the groundwater elevation is below the permanent pool water level, lining of the permanent pool area with an impermeable material may be required to ensure permanent pool levels are maintained. A liner may also be required when groundwater contamination may be a result of the permeable soils and the water quality within the stormwater management facility. The type and thickness of lining material shall be based on Geotechnical recommendations; however, a clay liner is preferred over synthetic materials for stormwater management facilities.

Where the groundwater elevation is above the permanent pool water elevation, an investigation shall be undertaken to assess the impacts of a localized reduction in groundwater levels, potential impacts to groundwater aquifer systems and flow regimes, watercourse baseflow quantity and temperature, and to assess potential slope stability and groundwater seepage concerns within the facility. The scope of this investigation will be determined based on site specific conditions. The consultant shall consider all feasible design alternatives to limit or negate any impact to local groundwater levels to the satisfaction of the Town.

The forebay should always be lined where the majority of the contaminants are contained. If an impermeable liner is required, the liner is to be constructed of impermeable clay or silt as per the geotechnical engineer's recommendation. The use of a manufactured bentonite geosynthetic liner is not supported. The installation of the liner must be supervised and certified by the geotechnical engineer.

8.10.7 Fire Use

In certain locations of the Town (e.g., remote development locations where access to fire hydrants is not available), and subject to review by the Town, it may be desirable to utilize the SWM pond as a source of water for fire use by incorporating a dry hydrant design. The design must meet the requirements of the Ontario Building Code for dry hydrants which is currently in accordance with FPA 1142, Water Supplies for Suburban and Rural Fire Fighting.

8.10.8 Sediment Forebay Bottom

A berm shall be constructed with a forebay spillway invert at the NWL with appropriate erosion protection to enable, as a minimum, the flow of the water quality event (25 mm event) without overtopping any other part of the forebay into the main cell of the facility. The minimum top width of the berm shall be 1.0 m and side slopes 3:1.

A dewatering sump shall be installed in the forebay to enable the drawdown of the permanent pool for maintenance and sediment removal. Where feasible, the forebay sump shall be connected to the pond outlet structure with a control valve to drain by gravity. Where draining by gravity is not feasible, a dewatering sump shall be included and drained by pump.

A Geotechnical Engineer must certify that the forebay bottom design has sufficient bearing capacity to support maintenance equipment assuming the forebay has been drained.

8.10.9 Sediment Drying Areas

Sediment drying areas are to be incorporated into the design of wet end of pipe stormwater management facilities such that water from the sediment drains back into the sediment forebay with a slope of 2% to 4%. The sediment drying area shall be designed to:

- Accommodate 30% of the forebay volume.
- Have a maximum sediment stockpile depth of 1m.
- Have a maximum sediment side slopes of 10:1.
- Located in areas that avoid high publicity.
- Is accessible from the maintenance access road.
- Is located above the five (5) year water level.
- Setback a minimum of 6 m from property line.

8.10.10 Inlet Structures

Inlet structures shall be installed with the invert set to the NWL or higher. Suitable erosion control and energy dissipation treatment shall be provided at all inlets to the pond. The sizing of rip rap or river stone shall be based on appropriate erosive velocity calculations.

Maintenance access roads shall be provided to all inlet structures.

Headwalls, barricades and safety grating shall be installed at all inlets as per OPSD 804.040, OPSD 804.030, OPSD 980.101 and OPSD 804.050 respectively. SWM pond inlet elevations are to be designed such that the one (1) in five (5) or ten (10) year storm design sewer capacity as per the storm sewer design sheet is maintained and not reduced due to tail water conditions.

8.10.11 Outlet Control Structures

Outlet control structures shall be designed with flow regulating devices to control the flow and pond drawdown time. The standards for end of pipe stormwater management pond outlets are as follows:

- a) A control manhole with a central wall designed with an orifice and/or notches to provide flow control and located at the top of the berm outside of the emergency spillway.
- b) If feasible, the intake pipe will be sized for the 100-year flow have sufficient cover to prevent freezing. For larger catchments to reduce the intake pipe size, a grated inlet can be used preferably above the 25-year water level.
- c) Where the permanent pool elevation is greater than 1 m above the obvert of the intake pipe, a reverse slope pipe shall be used. The intake pipe must be anchored and stabilized and be fitted with a grate of sufficient size that a swimmer would not be pinned against it at high flow.
- d) Where the permanent pool elevation is less than 1 m above the obvert of the intake pipe, the outlet should be designed with a heavy duty galvanized CSP riser with prepunched perforations with 1.5 times the 100 year flow capacity, a lockable non-hinged lid and large riprap placed against the riser to provide protection and filtering of stormwater. No hickenbottom or flow controls shall be in the riser.
- e) The low flow orifice on the center wall should be designed with an adjustable knife gate valve to control the flow and pond drawdown time and be accessible for adjustment through a standard manhole cover without entering the manhole. This would provide the Town with the ability to:
 - Adjust the low flow discharge to set the draw down rate (details provided in the Operations and Maintenance Manual).

- Open the valve fully to clear any clogging in the inlet pipe.
- Shut the valve to control any spills from moving downstream.

The outlet should also include a maintenance pipe with shut off valve for draining the SWMF if possible.

The minimum design orifice size is 75 mm with filtered stormwater, or 100 mm. Outlet structures are to be designed in a safe and aesthetically pleasing manner with the majority of the structure contained within the berm.

Suitable erosion control and energy dissipation treatment shall be provided at the pond outfall. The sizing of rip-rap or river stone at the outfall shall be based on appropriate erosive velocity calculations.

Maintenance access roads shall be provided to all outlet structures.

The outlet structure should be designed to operate under free-flowing conditions where feasible. The return period water surface elevations of the receiving body must be determined and verified to ensure the proper operation of the outlet structure. Where it is not feasible to operate the outlet structure under free-flowing conditions, appropriate submergence calculations must be completed to ensure that the outlet structure is sized correctly.

8.10.12 Fencing and Gates

Fencing shall be installed where the stormwater management facilities abut private lots, municipal boundaries, elementary schools and active recreation areas frequented by young children unless maximum slopes of 6:1 are provided. Town may request to install fencing in other conditions on project by project basis. Where required, fencing shall be installed as per Town's Standard Drawings.

All stormwater management facilities are to be designed such that perimeter fencing is not required where it is adjacent to municipal right of ways. Gates with a locking system shall be provided on all maintenance road access points.

8.10.13 Signage

Town Standard Sign, **TOESD 818**, shall be clearly visible and erected at the stormwater management facility's maintenance access road entrances, as approved by the Town. Town Standard signs shall be supplied and installed by the developer and designed in accordance with Town standards.

Warning signs shall be clearly visible and erected at all access points (maintenance access roads or pedestrian trail access points) to the stormwater management facility. Warning signs shall be

supplied and installed by the developer and designed in accordance with **Town of Erin Standard TOESD 818.**

8.10.14 Geotechnical Review

As part of final design, the geotechnical engineer should review the detailed design of the stormwater management facilities as well as the procedures outlined in the operation and maintenance manual and provide written certification confirming that they meet current geotechnical standards and are suitable from a geotechnical perspective. Drawing for the SWM facilities should include any geotechnical design parameters required such as soil and compaction specifications for berm construction, sub-base for maintenance roads and erosion protection materials. The same requirements are required for temporary erosion and sediment control facilities.

8.10.15 Aesthetics and Landscaping

The stormwater management facilities shall be constructed with acceptable building materials (e.g. no gabions) to ensure that the pond is an aesthetically pleasing component of the community. Stormwater management facilities shall be integrated with parks and trails where feasible. Access to the SWM ponds by unauthorized vehicles should be restricted by the placement of armour stone and large trees around the perimeter where there is no fencing.

8.10.16 Trails

Pedestrian circulation trails shall be incorporated into SWM facilities where public safety has been fully addressed in terms of access, side slopes and fencing requirements. The feasibility of connections to adjacent neighborhood parks, recreation areas and existing trail networks is to be explored as part of the initial SWM facility submission plans to the satisfaction of the Town. Wherever possible trails shall be co-located with maintenance access roads.

8.10.17 Operations and Maintenance Manual

A stand-alone operations and maintenance manual will be required as part of the design of each facility, including inspection checklists, maintenance descriptions and projected frequency, as well as recommendations for facility cleanup. Refer to Section 3.1.4.

8.11 FACILITIES PLANTING GUIDELINES

Stormwater Management areas will be landscaped with native species.

Grand River Watershed

Facility configuration and landscaping to incorporate design recommendations outlined in the document entitled “Design Principles of Stormwater Management Facilities” August 1996. A copy of the document can be obtained from the Grand River Conservation Authority.

Credit River Watershed

Facility configuration and landscaping to incorporate design recommendations outlined in the document entitled “CVC Stormwater Management Guidelines, May 1996” under the SWM requirements section and “CVC Stormwater Management Facility Planting Guidelines, February 16, 2000”.

8.11.1 Landscaping

In cases where there are residential lot(s) adjacent to a stormwater management facility, a minimum 6 m wide landscaping buffer with a maximum slope of 4:1 will be required between the maintenance access route and the residential lot(s) to provide separation between the stormwater management facility and private property. This buffer can be included within the stormwater management block.

8.11.2 Planting Zones

SUBMERGENT (Deep Water)

- Water depth 0.5 m to 2.0 m.
- Planting is to consist of a combination of both floating and submergent species.
- Planting must include at least (3) three species each of robust, broadleaf and narrow leaf plant varieties.

AQUATIC FRINGE (Shallow Water)

- Water depth 0.0 m to 0.5 m.
- Planting is to consist of a combination of both floating and submergent species.
- Planting must include at least (4) four species each of robust, broadleaf and narrow leaf plant varieties.

SHORELINE FRINGE (Extended Detention)

- 1.0 m (horizontal) from the permanent pool elevation.
- Plantings zone appropriate wetland species must include perennial sedges, rushes and wild flowers in combination with shrubs and wetland seed mix.

- The shoreline fringe is subject to fluctuations in water levels which will result in regular flooding and therefore plant selections must be flood tolerant.

FLOOD FRINGE

- 2.0 m (horizontal) from the limit of the shoreline fringe limit to the 100 year flood level.
- Plantings must include a diverse variety of no less than five (5) flood tolerant species each of shrubs, deciduous trees and coniferous trees.
- Trees and shrubs within the flood fringe will provide canopy structure to mitigate thermal effects on water temperature.
- Herbaceous plant material may be provided by the use of an approved wet meadow seed mix which will be applied in combination with an annual rye nurse crop or suitable equivalent nurse crop.

UPLAND

- Includes all areas outside the flood fringe.
- Plantings will include a minimum of seven (7) species each of drought tolerant shrubs, deciduous trees and coniferous trees.
- Upland planting is intended to provide visual screening, aesthetic appeal, wind blockage and shading to mitigate thermal effects on water temperature.
- Tree plantings to have no more than five (5) trees of the same species in a grouping.
- Provide a minimum 1.5 m buffer between plantings and any structures such as maintenance roads and drying areas and fencing which abuts residentially zoned property.
- Trees planted along fenced areas, bordering residential properties should be structurally sound, strong branched so to prevent falling branches into adjoining residential properties.

8.11.3 Planting Guidelines

AQUATICS (Submergent and Aquatic Fringe)

- Spacing requirements for aquatics in plug form is five (5) units per m².
- Spacing requirements for aquatics in 100 cm potted form is four (4) units per m².
- Spacing requirements for aquatics in 150 cm potted form is three (3) units per m².
- Cattails (*Typha* spp.) will be planted as interim perimeter vegetation in sediment forebays to increase sediment trapping. The use of this material will not limit maintenance access and it is acceptable that this material will be removed during dredging operations.

- Other aquatic species will not to be placed within the forebays as they would be less likely to re-colonize after dredging operations.
- Plant material must be comprised of 100% native stock.
- Protection from geese and other waterfowl may be required during initial aquatic plant installations.
- Aquatic fringe plant installations should be installed one (1) full growing season after that of both the shoreline and flood fringe or at such time as a complete vegetative buffer is established around the pond perimeter as deterrence to geese.

TERRESTRIAL (Shoreline Fringe, Flood Fringe and Upland)

- Do not utilize plant material which has been removed or harvested from natural wetlands or roadsides as they may contain invasive or non-native species.
- Plant material must be comprised of 100% native stock from a reputable.
- Grower/supplier.
- Plant shrubs in groupings of no less than 15 units [and no more than thirty (30) units] to promote both colonization and spreading.
- Shrubs are to be no less than 60 cm height (container grown stock only).
- Deciduous trees within the flood fringe are to be no less than 50 mm caliper stock. Canopy to be structural sound with strong central leader, no co-dominant leaders will be accepted. Canopy to be healthy and balanced around main central trunk of tree with no rubbing branches nor damages/inclusions on bark. Bio-degradable support materials shall be as per Town standards. Metal “T” bar and wire support will not be accepted.
- Deciduous trees within the upland may utilize a combination of caliper material and whip stock where caliper trees are planted based on a rate of one unit per 25 m². Whip stock is to be installed at a rate of 6.25 units per 25 m².
- Whips and any bare root stock to be planted prior to the third Friday of May in any given year.
- Coniferous material will be no less than 2000 mm in height where height is measured from the top of the root ball to the first whorl (does not include the leader).
- Where applicable, shrubs, deciduous trees and coniferous trees are to be installed in accordance to current Town Standards.

- Rodent protection will be installed around the base of all deciduous trees. It will be the installer's responsibility to remove rodent protection two (2) years prior to accepted/assumed. Biodegradable options will also be considered.
- Weed abatement measures will be used around trunks of trees using mulch, coco fiber mats or Town approved substitute.
- Bio-engineering (e.g. live staking) should be implemented on steep slopes in conjunction with other stabilization methods. Live staking will not be considered for use against density calculations for plant material.

8.11.4 Topsoil

- Topsoil must meet the current Ontario Provincial Standard Specification No.570 (OPSS-570).
- Topsoil will be laboratory tested and the subsequent findings forwarded to Town for approval prior to placement of topsoil.
- Testing must demonstrate that topsoil has sufficient organic and nutrient content and is suitable for sustaining plant material which is to be placed into the pond and/or wetland.
- Soil amendments required as a result of laboratory testing must be completed prior to or during the placement of topsoil in accordance with laboratory findings and amendment requirements.
- For terrestrial habitats in the flood fringe, provide 0.35 m of topsoil.
- For terrestrial habitats in the upland area, provide 0.20 m of topsoil.
- For aquatic habitats, provide 0.45 m of topsoil for the first 1 m from the permanent pool elevation.
- Stabilize topsoil after placement prior to the installation of woody plant material. In the event that erosion control blankets are utilized in combination to approved seed mixes for stabilization purposes, the netting and blanket material will be 100% bio-degradable. Photo-degradable plastic or plastic netting is not permitted for ground stabilization.
- If topsoil stabilizations cannot be completed within one (1) construction year's growing season, the topsoil should not be placed until the following spring. In this event, sediment controls must be in place to prevent erosion of stockpiled materials.

8.11.5 Seeding

- All seed mixes are to be placed in combination with an annual rye nurse crop or suitable equivalent nurse crop and will be applied at a rate of 12 kg per hectare.

- All upland areas are to be seeded using seed mixture indigenous to the area and applied at a rate of 20 kg per hectare.
- Shoreline Fringe and Flood Fringe areas are to be seeded using an approved 'Wet Meadow' or seasonally flooded annual/perennial seed mix which are to be applied at a rate of 20 kg per hectare.
- Seed application is to follow directly after topsoil placement in order to establish vegetative cover quickly for stabilization of topsoil. Seed application should be done at a time of year to ensure the best possible germination and mitigate seed loss.
- Erosion control blankets are to be placed over top of seeded areas immediately after application where required.

8.11.6 Guarantee Period

- All aquatics, perennials, trees and shrubs are to be guaranteed for a period of not less than one year from the beginning of the maintenance period.
- If aquatics, perennials, trees and/or shrubs are found dead, diseased, missing or are deemed to be unhealthy within the guarantee period the defective plants are to be replaced and re-guaranteed for an additional two (2) years.

8.11.7 Monitoring and Maintenance

- Vegetation monitoring plans and schedules are required with all landscape plan submissions which will include monitoring of the performance and effectiveness of interim measures (e.g. nurse crops) and monitoring of plant health during droughts.
- Watering activities should continue for the first two years after planting.

8.12 FACILITIES MAINTENANCE AND INSPECTION PROTOCOL

8.12.1 Operations and Maintenance Manual

Prior to final Site Plan or Plan of Subdivision approvals at the detailed design stage, a standalone Operation and Maintenance Manual shall be prepared for all proposed SWM facilities that identifies on-going operation protocol including inspection and maintenance issues, inspection checklists, maintenance descriptions and projected frequency, as well as recommendations for facility cleanup. The Toronto and Region Conservation Authority (TRCA) document entitled "Inspection and Maintenance Guide for Stormwater Management Ponds and Constructed Wetlands", dated April 2018, can be used as a guide for development of the Operations and Maintenance Manual. The specific requirements that must be included in SWM facility Operation

and Maintenance Manuals submitted to the Town shall include, as a minimum, the items outlined below.

8.12.2 Background Information

Introductory material describing the property location, including both municipal and legal descriptions, and drainage area tributary to the facility.

8.12.3 Design Elements and General Description of Operation

- A general description describing the operation of the SWM facility and applicable water quality, erosion and quantity control criteria.
- Indicate and describe the various design elements of the SWM facility (e.g. sediment forebay, permanent pool, extended detention and flood storage, drawdown time and how the facility operates under various storm events, inlet and outlet control structures including maintenance by-pass valve, drawdown valve and spill containment valve, if applicable).

8.12.4 Responsibility for Maintenance Activities

Provide details as to who is responsible for SWM facility maintenance before and following assumption by the Town.

8.12.5 Inspection and Maintenance Procedures

Prepare a list of key inspection items including but not limited to the following:

- check inlet and outlet structures for accumulation of miscellaneous construction debris and other trash that may affect performance
- check for unusually long extended detention drawdown time that could indicate a blockage in the outlet structure
- check for sediment accumulation in the forebay and downstream of the facility
- note evidence of seepage along the berms
- check for vandalism including illegal access (e.g., gates) or encroachment around the perimeter of the facility
- confirm that safety and security measures are in good working order
- check for the presence of any unusual erosion around berms and inlet or outlet structures
- complete visual inspection to confirm that vegetation is healthy

- complete visual inspection to confirm no oil sheen present on water surface or the presence of other visible contaminants or odours
- check drawdown valve and spill containment valve (if applicable) for proper operation

Provide recommended maintenance procedures for items including but not limited to the following: grass cutting around walking trails; weed control; upland and fringe plantings; shoreline fringe plantings; aquatic vegetation replanting; outlet adjustments; bathymetric survey to assess the need for sediment removal; trash removal; and winter maintenance.

8.12.6 Monitoring Program and Performance Evaluation

- Prepare a recommended plan for water quality monitoring that will accurately characterize the average water quality treatment provided by the SWM facility per the Lake Simcoe Protection Plan and demonstrate that it is in accordance with the MECP ECA.
- Include recommended procedure to verify the rating curve of the outlet control structure.
- Provide a recommended plan to complete a SWM facility bathymetric survey to determine the quantity of sediment to be removed (if any).
- Include a list of key structures to confirm as-constructed elevations and dimensions (e.g., inlet, outlet control structure components including weirs and orifices) and proper installation (e.g., safety and security measures, vegetation, erosion protection).

8.12.7 Removal and Disposal of SWM Facility Sediments

- Indicate the procedure required to dewater the permanent pool prior to sediment removal and how to divert storm flows away from the facility during maintenance operations.
- Provide a sediment handling, removal and disposal plan including but not limited to the following: written notification to residents within 120 m of the SWM facility identifying maintenance works and duration; erosion and sediment control plan to prevent the release of TSS to the downstream receiver; treatment, sediment dewatering and drying techniques to be used; and the required chemical analyses to be completed in accordance with Ontario Regulation 558/00 prior to disposal.

8.12.8 Estimated Annualized Operation and Maintenance Costs

Provide calculations of the estimated annualized operation and maintenance costs for the SWM facility. Costs should include but not be limited to the following: debris and litter removal; grass cutting and weed control (if applicable); maintenance of aquatic/shoreline fringe and upland/flood fringe vegetation; sediment testing; sediment removal and disposal; inlet/outlet structure repairs; side slope and access road repairs; and retaining wall repairs.

8.12.9 Primary Tables and Supporting Calculations

- SWM facility inspection check list.
- Estimated annualized operation and maintenance costs and supporting calculations.
- Sediment accumulation cleanout frequency calculations.

8.12.10 Primary Figures and Drawings

- SWM facility location plan.
- Post-development drainage area plan tributary to the SWM facility.
- SWM facility stage-storage-discharge relationship and curve.
- General plan for the SWM facility and detailed drawings of key elements (e.g., inlet, outlet control structure, maintenance valve, spill containment valve).

8.12.11 Stormwater Management Pond Post - Cleanout (Final Acceptance)

Following removal of accumulated sediment, the developer's engineer shall provide a survey of the cleaned out SWM facility and provide an As-Recorded SWM facility drawing which includes the following;

- A summary table with the design, pre, and post cleanout permanent pool volumes.
- A summary table with the design and as-recorded elevations of inlet headwall(s), outlet(s), weir(s), forebay berm inverts, emergency spillway inverts, and any other structures which are required for the facility to function as designed.
- Plan and sections of the pond which illustrate the maintenance access, hydraulic structures, and representative pond side slopes.

A geodetic monument shall be installed on the inlet headwall with the exact location and elevation included on the As-Recorded SWM Pond drawings set.

All required warning signage shall be installed with proof of installation provided to the Town via timestamped photographs.

The developer's engineer shall provide the Town with an Engineering Certification letter which confirms that all of the components of the SWM facility are in good condition and do not require repair, and have been installed in general conformance with the approved SWM Facility design and final approved drawings. The additional information should be included in a package to the Town:

- The approved SWM Facility Report.

- All approvals associated with the SWM facility and associated infrastructure (e.g. outfall headwalls to the natural environment) shall be provided to the Town. Approvals should include the Ministry of Environment, Conservation and Parks (MECP), Environmental Compliance Approval (ECA), formerly called Certificate of Approval (COA); possibly Ministry of Natural Resources and Forestry; and/or Fisheries and Oceans Canada (DFO).

The developer shall provide the Town with a Landscape Certification letter which confirms that all of the plantings associated with the SWM facility are in good condition and do not require replacement, and are in general conformance with the approved landscape plans. The additional information should be included in a package to the Town:

- The final approved Landscape plans associated with the SWM facility.
- All approvals associated with the landscape plans.

8.13 WATER QUALITY TREATMENT UNITS

8.13.1 Oil/Grit Separators (OGS)

Oil/grit separators are most appropriate for commercial/industrial land use and shall not be used as a standalone Stormwater Management Plan, but rather part of a “treatment train” approach to achieve the required water quality treatment. Oil/grit separators typically serve drainage areas under 2 ha and are predominantly encouraged by the Town to be used for spill control. Oil/grit separators are also appropriate for providing water quality control for redevelopment, or infill areas which typically have space limitations and where a stormwater management pond is not practical. Oil/grit separators should not be used as a substitute for an end of pipe SWM facility forebay.

Supporting calculations and anticipated maintenance requirements shall be provided to the Town along with certification of the design by a Professional Engineer. Additional documentation may be required on a case-by-case basis.

All oil/grit separator units shall be Contech Stormceptor™ units. Alternate products may be proposed by the designer but will be subject to review and approval by the Director of Infrastructure Services.

8.13.2 Roof Top and Parking Lot Storage

The use of parking lot storage for stormwater management has some challenges primarily the potential for flood damage to private property and the continual functioning of such devices if on-site controls are altered after construction (e.g. flow control inadvertently removed).

The use of parking area to provide peak flow control is generally not preferred, and shall be considered on a site specific basis by the Town through pre-consultation. On-site controls should generally be avoided on school sites and other sensitive institutional uses.

Water quality and quantity controls in new development areas should be provided in Town-owned municipal blocks or easements.

Roof Top Storage

When used, flat roofs may be used to store runoff to reduce peak flow rates to storm sewer systems to mitigate the need for downstream storm sewer size increases. Per the SWMPD Manual (MOE, 2003), rooftop storage can typically store 50 mm to 80 mm of runoff subject to the roof loading design. Detention time is typically between twelve (12) to twenty-four (24) hours.

Supporting calculations and design drawings must be provided to indicate the following:

- Steady state hydrologic modeling to determine peak flow rate rather than rational method.
- The total number and location of proposed roof drains and emergency overflow weirs.
- The type of control device proposed (i.e. product name and manufacturer). Tamper proof devices are preferred where feasible (provision of shop drawings required).
- Unless otherwise deemed appropriate by the Town and/or CA, a maximum flow rate of 42 L/s/ha of roof area.
- Product specifications (i.e. design release rates for identified control devices).
- Emergency overflow weirs shall be provided at the maximum design water level elevation.
- The maximum ponding depth, storage volume, and drawdown time for roof top storage during the 2-yr through 100-yr design storms.
- Roof top control devices may require registration on title as part of the Site Plan Agreement and/or Subdivision Agreement).
- Certification from the structural and mechanical engineers that the roof structure and vertical drain pipes are designed to account for the roof top storage.

Parking Lot Storage

Since vehicles may be flooded, with water entering the passenger compartment at depths of less than 0.3 m, the use of parking lot storage represents a significant liability risk. Where other options for stormwater management practices exist, it is the preference of the Town that alternatives to parking lot storage be used. Should parking lot storage be supported, the following conditions must be met:

- Parking lot storage may require registration on title as part of the Site Plan Agreement and/or Subdivision Agreement) to ensure they are properly maintained and cannot be removed or altered during future site alterations without the provision of adequate alternative storage.
- The site owner is responsible for all liability related to the proposed parking lot storage system, including all damages resulting from the designed operating conditions and any downstream damages resulting from removal, modification or lack of maintenance to on-site controls.
- Parking lot storage must be controlled by pipe size reductions within the storm sewer network and not through the use of orifice plate restrictors to a minimum size of 100 mm.
- Surface ponding is only allowable during storm events greater than the 1:5-year design storm.
- The maximum allowable ponding depth within the parking lot is to be limited to 0.3 m; however, maximum ponding depths of 0.2 m are preferred.
- The 100-year ponding elevation and storage volume provided at each ponding location must be shown on the design drawings.
- An emergency overflow system and overland flow route must be provided to allow all runoff exceeding the 100-year storage to be safely routed from the site to a suitable outlet (i.e. municipal R.O.W.) This flow route must be shown on an engineering plan.

8.14 END-OF-PIPE CONTROLS

End-of-pipe control facilities shall provide the required quantity and quality control in accordance with the governing guidelines which are currently documented in the MECP's Stormwater Management Planning and Design Manual (MOE, 2003), unless otherwise specified below by the Town.

The planning and design of each pond shall also focus on opportunities to integrate the pond with the surrounding topography and land uses. Ponds are to be created as public amenity features and are to be safe, significantly visible and accessible to the general public. Opportunities for linkages through the use of trails to larger open space, floodplain areas or other SWM facilities are to be maximized.

8.14.1 Wet Pond with Extended Detention

Wet ponds are typically the preferred end-of-pipe control facility for drainage areas greater than 5 ha. Wet ponds shall be designed in accordance with the governing guidelines unless otherwise specified in the Town's guidelines.

8.14.2 Wetland with Extended Detention

A constructed wetland is an acceptable stand-alone end-of-pipe control facility. Constructed wetlands shall be designed in accordance with the governing guidelines unless otherwise specified in the Town's guidelines.

8.14.3 Hybrid Wet Pond / Wetland with Extended Detention

A wet pond / constructed wetland hybrid is an acceptable stand-alone end-of-pipe control facility. Hybrid wet ponds / constructed wetlands shall be designed in accordance with the governing guidelines unless otherwise specified in the Town's guidelines.

8.14.4 Dry Pond with Extended Detention

Dry ponds servicing development larger than 5 ha will not be permitted unless Low Impact Development has been designed to infiltrate the runoff from the 25mm storm event. Dry ponds for smaller development may be used as a part of a treatment train approach provided that an enhanced level of water quality treatment is achieved.

8.14.5 Infiltration Basin

In general, infiltration basins shall not be accepted as a stand-alone end-of-pipe facility, unless as part of a treatment train approach or as an additional feature. Infiltration basins shall not be permitted for drainage areas > 5 ha.

8.14.6 End of Pipe Water Depths

The following water depths will be permitted in the End of Pipe facilities:

Table 19: End of Pipe Facilities

| | WET POND | WETLAND | DRY POND |
|-------------------------------------|----------|--|----------|
| Maximum Permanent Pool | 2.5 m | | |
| Average Permanent Pool | 1 - 2 m | 150 to 300 mm, 1 m at inlet and outlet | |
| Extended Detention (Active Storage) | 2 m | 1 m for storms < 10 yr | |
| Quality and Erosion Control | | | |
| Maximum Overall depth | 3 m | 3 m | 2 m |
| Forebay Minimum Depth | 1.5 m | 1 m | 1.5 m |

8.14.7 Maintenance Access

Maintenance access roads are required to all inlet and outlet structures, sediment forebays, sediment drying areas (if applicable), and emergency spillways associated with the stormwater management facility. Co-location of access roads with trails shall be implemented wherever possible. Where feasible, two access points shall be provided from the municipal road allowance such that the access road is looped to key hydraulic features. In situations where this is not practical, dead end access roads shall be designed with a hammerhead turning area consisting of a minimum hammerhead width of 17.0 m and a 12.0 m centerline turning radius, however this option is not ideal.

Where the access road enters the forebay below the NWL, the forebay ramp shall be constructed consistent with the lining of the bottom of the forebay or as recommended by a geotechnical engineer. Minimum width of 4.0 m and a maximum grade of 10% should be used. Ramp access should favour “green” solutions.

The access roads shall provide for all-weather ingress and egress with a minimum width of 4.0 m and a maximum grade of 3%. The maintenance access road shall consist of 50 mm HL4 with a minimum base of 300 mm of compacted granular “A” (or as recommended by a geotechnical engineer) which extends 0.5 m on either side of the paved surface. Curves on all access roads shall have a minimum centerline radius of 12.0 m. Maintenance access roads shall be set a minimum of 300 mm above the maximum pond water level.

At locations where overland inlet flow routes or the emergency spillway cross the maintenance access, reinforcing measures shall be incorporated to strengthen the access route to carry ruck loading and permit bike/stroller crossing.

8.14.8 Berming

Berms around wetlands and wet ponds shall be designed with a minimum top width of 3.0 m (where trails and access roads are not located) with a 3:1 maximum side slope on the outside.

The core of the berms shall be constructed with engineered fill on the basis of the recommendations of a licensed geotechnical engineer. Topsoil is not permitted for berm construction except as a dressing to support vegetation on the top of the core.

For pond berms exceeding 2.0 m in height from the top of the berm to the toe of slope, the berm must be designed by a qualified professional engineer in accordance with the latest edition of the Ontario Dam Safety Guidelines (MNR).

8.14.9 Erosion and Sediment Control

Sediment control measures in accordance with the approved Erosion And Sediment Control (ESC) plan must be in place before any other construction activity happens on site.

A complete ESC plan includes the following:

- a) Erosion and Sediment Control (ESC) Plans (report and drawings)
- b) Spill Control and Response Plans
- c) Inspection and Maintenance of ESC
- d) Performance Monitoring and Reporting

This section presents the minimum criteria for the design of some commonly used erosion and sediment controls. For additional information and/or information on control options that have not been included in this section, please also refer to the latest revision of the MECP's "Stormwater Management Planning and Design Manual".

The ESC report will include the following:

- a) Project Description
- b) Conditions of Existing Site
- c) Condition of Existing Receiving Water
- d) Adjacent Areas and Features
- e) Soils
- f) Critical Areas
- g) Permanent Stabilization
- h) Design Details of ESC Measures
- i) Record Keeping Procedures
- j) Stockpile Details
- k) Emergency Contacts
- l) Stamped and Signed Report

A complete application submission requires ESC drawings that work with the ESC report to form a complete ESC Plan. The ESC Drawings should include the following:

- a) General Items
- b) Existing Contours

- c) Existing Vegetation
- d) Water Resources Locations (lakes, rivers etc.)
- e) Regional Storm Floodplain and CA Regulated Areas
- f) Critical Area
- g) Proposed Contours/Elevations
- h) Site Boundary Limits
- i) Existing and Proposed Drainage Systems
- j) Limits of Clearing and Grading
- k) Stockpiles and Berm Data
- l) ESC Measures Locations and Details
- m) Stormwater Management Systems
- n) Stormwater Discharge Locations
- o) Access Road
- p) Internal Haul Road
- q) Construction Phasing and Scheduling
- r) Inspection and Maintenance
- s) Signed and Stamped Drawings

The ESC controls should be designed using a phased approach whenever feasible to minimize the exposed area of the site at any given time. The ESC report should lay out the various phases of construction and any changes or additions to the ESC systems for each phase. Erosion prevention is the preferred mitigation measure for eliminating and/or reducing the potential for sedimentation.

Topsoil stripping should be conducted in a logical sequence in order to minimize the areas where soil is exposed. Any areas that are scheduled to remain exposed for longer than thirty (30) days should be protected with vegetative cover. The method used to establish vegetative cover will vary depending on the soil type, site grading and time of year.

This section presents the minimum criteria for the design of some commonly used erosion and sediment controls. For additional information and/or information on control options that have not been

included in this section, please also refer to the latest revision of the (MECP) Stormwater Management Planning and Design Manual.

The controls should be designed using a phased approach whenever feasible to minimize the exposed area of the site at any given time. There must also be a contingency plan for repair, replacement and upgrading of control measures as required to achieve adequate performance at all times.

8.14.10 Runoff Control

The development of the control plan shall examine concentrated runoff from adjacent areas that will pass through the site and shall provide for the diversion of the runoff around disturbed areas. If this is not possible, the runoff shall be directed into armoured channels flanked by silt fencing with appropriate low point protection and shall outlet into a treatment facility prior to discharge.

For sites where sediment control ponds are not being proposed, sediment control fences and cut off swales/channels or equivalent control measures shall be placed along all down gradient boundaries of the site.

For sites adjacent to existing residential areas, a cut-off swale/channel shall be placed around the entire perimeter of the site to prevent drainage onto private lands. A 3.0 m wide buffer strip and/or sediment control fence shall be provided along the perimeter of the down gradient boundaries of the site.

8.14.11 Temporary Sediment Control Ponds

Temporary sediment control ponds are required for any project that has a construction area greater than 5.0 ha.

The location of the pond(s) shall intercept runoff from the entire disturbed area unless other controls are implemented, in conjunction with the pond, to ensure that adequate performance is achieved for the entire area.

In general, the pond shall consist of a:

- a) Permanent pool to contain accumulated sediment and post-storm waters;
- b) Water quality treatment volume that allows for settlement of suspended sediment from storms; and
- c) Forebay to quiet incoming flow if the construction project is anticipated to take place over more than one year.

The required active storage volume shall be designed with a minimum of 125 m³/hectare of contributing area.

The required permanent pool volume shall be designed with a minimum of 125 m³/hectare of contributing area.

The draw down time shall be a minimum of twenty-four (24) hours, or as required by the governing Conservation Authority.

The outlet works shall consist of a perforated riser system, with a minimum orifice diameter of 75 mm.

The forebay shall be designed with a minimum depth of 1 m, a maximum volume of 20% of the permanent pool, have a stable bottom to allow mechanical clean out, and incorporate sediment depth indicators.

The overall pond shall be designed with a minimum depth of 1.0 m, a maximum depth of 2.5 m, maximum side slopes of 4:1, and an emergency spillway sized to safely convey the 1:100 year storm event from the contributing area.

8.14.12 Silt Fences

Silt fence is to be installed on the perimeter and on the up-gradient side of sensitive areas, streams and rivers, and at the base of slopes. It should not be used in areas of high flows.

When silt fence is proposed, it shall be:

- a) Aligned with site contours.
- b) A minimum above grade height of 900 mm with a minimum of 300 mm of the fabric toed into the ground.
- c) Constructed of suitable woven UV stabilized fabric (with a weave density of 270R or greater) fastened with wire fasteners to 150 mm page wire fencing or acceptable equivalent.
- d) Supported by steel T bar fence posts with a separation distance of no more than 2.5 m.
- e) Accompanied by a vegetative buffer strip on the down gradient side.

8.14.13 Vegetative Buffer Strips

Vegetative Buffer Strips shall be provided between the site alteration area and every down gradient protected area. They shall be protected from up gradient erosion by silt fences and shall consist of established vegetation that is growing, whenever possible, on undisturbed soil.

They are to be a minimum of 3.0 m wide between the perimeter of the property and a disturbed area and a minimum of 15.0 m wide between surface water and a disturbed area. Additional width may be required if the adjacent surface water is classified as a cold water source.

8.14.14 Non-Vegetative Buffer Strips

Non-Vegetative Buffer Strips shall be installed where there is not a minimum undisturbed area of established vegetation down gradient of the site alteration area. They shall be a minimum of 2.0 m wide between the perimeter of the property and a disturbed area and a minimum of 15.0 m wide between surface water and a disturbed area.

A second silt fence must be installed no closer than 1.0 m to the primary silt fence and there must be space provided for access to clean out trapped sediment and complete any repairs to the fence.

8.14.15 Channel Low Point Protection (Stone Silt Traps)

Channel Low Point Protection Devices shall be constructed in channels and ditches that will contain concentrated flows to reduce the velocity; thereby reducing erosion of the sides and invert. They shall be designed as follows:

- a) So that the crest of the downstream device is at the same elevation as the downstream base of the device further upstream;
- b) With 100 mm to 150 mm diameter rip rap, wrapped in geotextile fabric, from the invert of the channel or ditch to a maximum of 250 mm below the top of the channel or ditch;
- c) With a downstream slope not to exceed 4H:1V and an upstream slope not to exceed 1.5H:1V;
- d) With a 2.5 m long excavated sediment trap approximately 600 mm in depth at the upstream face.

8.14.16 Construction Access Mats

Construction Access Mats shall be installed at all exits from the site and shall be designed and maintained to remove most of the sediment accumulated on vehicle tires. They shall be designed as follows:

- a) 300 mm of 50 mm – 100 mm clear limestone placed on a geotextile fabric suitable for allowing ex-filtration of water and preventing the quarry stone from becoming contaminated with the substrate soil (Terrafix 270R or approved equal).
- b) To be a minimum of 6.0 m in width and extend a minimum of 20 m onto the site.
- c) To be flanked by silt fences and vegetative buffers from the property line to the start of any on-site roadways (refer to **TOESD 505** for the detailed drawing).

8.14.17 Topsoil and Spoil Pile Management

Topsoil and spoil piles shall be designed such that they are not in low areas of a site where water may accumulate and they must be surrounded by one or more silt fences.

Any piles containing more than 100 m³ of material shall be a minimum of 15 m from a roadway or channel.

If topsoil or spoil piles are to be left in place for more than sixty (60) days, they shall be stabilized by mulching, vegetative cover, tarps or other equivalent means.

8.14.18 Drain Inlet and Catchbasin Protection

Protection of all potentially affected storm drain inlets and catchbasins shall be accounted for in the design.

Filter cloth protection may be used over the catchbasin inlet where ponding of water will not occur and where traffic will not affect the filter cloth. In all other cases, catchbasin inserts shall be used constructed of filter cloth with or without a metal support structure.

8.14.19 Site Dewatering

Effluent from site dewatering operations must not discharge directly into receiving bodies of water or streams.

Water pumped from the site shall be treated by control devices such as a sediment control pond, grit chambers, sand filters, upflow chambers, swirl concentrators or other appropriate controls, and must not contain particles more than 40 microns in size, or more than 100 mg/L of suspended solids.

9 Roads

This section specifies the requirements for designing, constructing and restoring roadways and driveways within the Town. Amendments to the Ontario Provincial Standards are contained within these standards and should be read carefully to ensure compliance during construction.

9.1 CLASSIFICATION

All roadways shall be classified in accordance with the Town's Official Plan and the classification of each roadway shall be confirmed with the Town.

All roadways are to be designed to urban standards unless specific approval is received from the Town. For land development projects, new roadways designed to rural standards may only be considered for estate residential or industrial developments.

Right of ways shall be a minimum of 20 m for local streets, 26 m for collectors, and 30 m for arterial roadways. The Town recognizes that these standards may not coincide with the minimum right of way information contained within the Official Plan; however, these standards shall take precedence.

Where a development adjoins or incorporates an existing County Road or Town arterial roadway as per the Town's Official Plan, the Developer shall deed to the County or the Town the required widening, which may be in excess of 20 m.

9.2 PAVEMENT DESIGN

The minimum pavement structure for the various road classifications is provided in the table below:

Table 20: Minimum Pavement Structure

| ROAD CLASS | SURFACE ASPHALT | BASE ASPHALT | BASE COURSE | SUBBASE COURSE |
|------------|-----------------|-------------------------|---------------------|---------------------|
| Local | 40 mm HL3 | 50 mm HL8 | 150 mm Granular 'A' | 300 mm Granular 'B' |
| Collector | 40 mm HL3 | 60 mm HL8 | 150 mm Granular 'A' | 400 mm Granular 'B' |
| Arterial | 40 mm HL3 | 100 mm HL8 in two lifts | 150 mm Granular 'A' | 450 mm Granular 'B' |
| Industrial | 40 mm HL3 | 110 mm HL8 in two lifts | 150 mm Granular 'A' | 500 mm Granular 'B' |

The pavement structures in Table 20 are sufficient for the following amounts of Equivalent Single Axle Loads (ESALs):

Table 21: ESAL's Corresponding to Pavement Structure

| ROAD CLASS | ESALs |
|------------|-----------|
| Local | 300,000 |
| Collector | 300,000 |
| Arterial | 1,500,000 |
| Industrial | 2,500,000 |

Table 20 presents the minimum pavement structures however, the Town will require the Geotechnical Engineer to recommend the depth of granular base, and type and thickness of asphalt based on site conditions for each project.

The pavement structures identified above are a minimum and the actual pavement structure may need to increase as a result of the following:

- Local conditions such as soil type or water table;
- Anticipated traffic loading;
- To ensure there will be no half load restrictions on collector, arterial, or industrial roadways; and
- Any other requirements identified in the geotechnical report.

All asphalt materials and work shall conform to OPSS 1150, OPSS.MUNI 1151, and OPSS.MUNI 1101.

9.3 GEOMETRIC ELEMENTS

The following geometric standards shall be applied:

Table 22: Geometric Standards for Road Design

| ROAD CLASS | ROW WITH (m) | MIN DESIGN SPEED (km/h) | PAVEMENT WIDTH (m) | MIN/MAX GRADE (GUTTER) (%) | MIN HORIZONTAL C/L CURVATURE (m) | VERTICAL CURVATURE MIN 'K' VALUE | | MIN TANGENT BETWEEN HORIZONTAL CURVES (m) |
|--------------|--------------|-------------------------|--------------------|----------------------------|----------------------------------|----------------------------------|-----|---|
| | | | | | | CRES T | SAG | |
| Local (uban) | 20 | 50 | 8.0 | 0.5/7 | 60 | 8 | 6 | 50 |

| ROAD CLASS | ROW WITH (m) | MIN DESIGN SPEED (km/h) | PAVEMENT WIDTH (m) | MIN/MAX GRADE (GUTTER) (%) | MIN HORIZONTAL C/L CURVATURE (m) | VERTICAL CURVATURE MIN 'K' VALUE | | MIN TANGENT BETWEEN HORIZONTAL CURVES (m) |
|--------------------|--------------|-------------------------|--------------------|----------------------------|----------------------------------|----------------------------------|-----|---|
| | | | | | | CRES T | SAG | |
| Local (rural) | 20 | 50 | 8.0 | 0.5/5 | 60 | 8 | 12 | 50 |
| Collector | 26 | 70 | 9.0 | 0.5/6 | 190 | 25 | 25 | 80 |
| Arterial | 30 | 80 | 14.0 | 0.5/5 | 340 | 50 | 30 | 120 |
| Industrial (urban) | 26 | 50 | 10.0 | 0.5/6 | 60 (See Note 1) | 15 | 12 | 50 |
| Industrial (rural) | 26 | 50 | 9.0 | 0.5/6 | 60 (See Note 1) | 8 | 12 | 50 |

Notes:

- 1) Shall provide pavement widening on horizontal curves as per Geometric Design Standards for Ontario Highways.
- 2) On rural roads, the cross-section will change to urban where centreline grades are equal to or greater than 5%.
- 3) K values less than those listed above may be considered for stop approaches with artificial lighting.
- 4) Minimum gutter grade along curved portion of the road shall be 0.7% where the road bend exceeds 45%.

9.3.1 Vertical Curves

For local streets, all changes in grade of 2% or more shall be accommodated through the use of a vertical curve.

For all other road classifications, a change in grade of 1% or more shall be accommodated through the use of a vertical curve.

9.3.2 Crossfall

Finished roadways shall have a minimum crossfall of 2%.

9.3.3 Curb Radii and Daylighting Requirements

The curb return radii, measured from edge of pavement, and daylighting requirements at intersections shall be in accordance with the table below:

Table 23: Intersection Daylighting Requirements

| ROAD CLASS | INTERSECTING ROAD CLASS | MINIMUM CURB RADII (m) | DAYLIGHTING (m) |
|------------|-------------------------|------------------------|-----------------|
| Local | Local | 9 | 3 |
| | Collector | 9 | 5 |
| | Arterial | 9 | 10 |
| Collector | Local | 9 | 5 |
| | Collector | 12 | 10 |
| | Arterial | 15 | 10 |
| Arterial | Local | 9 | 10 |
| | Collector | 15 | 10 |
| | Arterial | * (See Below) | 15 |
| Industrial | Any Other Class | 18 | 15 |

*A compound curve shall be provided in accordance with M.T.O. Geometric Design Standards for Ontario Highways to accommodate a Wb-15 vehicle.

9.3.4 Cul-de-Sacs

Permanent cul-de-sacs shall be constructed in accordance with the details provided in OPSD 500.020 or 500.030 and shall be designed with a minimum grade of 1% from the centre of the bulb to the curb.

Minimum gutter grades of 1% shall be maintained along the flow line of all gutters around the cul-de-sac. The design road grade on the cul-de-sac shall be such that the drainage is directed away from the end of the cul-de-sac and towards the beginning of the bulb area where catch basins are to be located.

All cul-de-sacs, bulbs and intersections shall be detailed at a scale larger than the road plan. The details shall show gutter, crown and other grades sufficient to determine that the road will properly drain and shall be used as a basis for layout.

The maximum permitted length of cul-de-sac shall depend on the density of development. The length of cul-de-sac shall be determined and measured from the nearest intersecting road to the beginning of the bulb, and the following criteria shall be used as a guideline.

| <u>Type of Development</u> | <u>Maximum Length of Cul-de-sac</u> |
|----------------------------|-------------------------------------|
| Single Family | 300 m |
| Semi-detached | 250 m |
| Townhouse/Row Housing | 200 m |

Exceptions to these maximums may be considered for privately serviced rural estate subdivisions with less than 40 units. Where 40 units or more, a divided entrance should be considered if a second access point is not feasible.

9.3.5 Community Mailboxes

Provisions shall be included in the design for community mailboxes. While the final locations are subject to approval by the Town and Canada Post, the designer must propose locations that are conducive to the pedestrian and vehicular movements anticipated in the area. As a result, placement on collector or arterial roads should be avoided. Further, mailboxes are to be located a minimum of 30.0 m from the edge of the road allowance at any intersection, preferably on a lot line and giving consideration to other aboveground features such as streetlights, fire hydrants, transformers, etc. Community mailboxes must have direct sidewalk access and are to face the sidewalk (if present). In rural areas, where sidewalk is not present, access is to be provided from the roadway. All Mailboxes must conform to Canada Post's Standard Drawings and Specifications.

9.3.6 Transitions

Where a new street is to connect to an existing street, whether the design includes an extension of the existing street or connects at an intersection, the design shall extend along all existing streets for a sufficient length to provide a satisfactory transition. In the case of an intersection, the distance must be equal to the greater of the required stopping sight distance or the turning lane development lengths, if applicable, for all legs of the intersection.

9.3.7 Curb and Gutter

For local streets, standard barrier curb as per OPSD 600.040 (single stage) or 600.070 (two stage) is permitted for multiple family developments. Semi-mountable curb as per OPSD 600.060 is permitted for developments with single and semi-detached housing. Curb cuts in residential areas shall be in accordance with OPSD 351.010.

For collectors, arterials, and industrial streets, standard barrier curb as per OPSD 600.040 (single stage) or 600.070 (two-stage) is required.

Concrete curb and gutter shall be in accordance with OPSS.MUNI 353, and shall meet the requirements of CSA A23.1, Exposure Class C-2, with a minimum compressive strength of 32 MPa at 28 days.

Curb ramps shall be provided at all sidewalk intersections with curb line. The transition from curb ramp to full curb shall be carried out over a length of 0.6 m and the dropped curb shall extend 0.3 m beyond the width of the sidewalk. If the resulting full curb between two sections of dropped curb for a sidewalk will result in a full curb section less than 1.0 m in length, the dropped curb shall be continuous, and the sidewalk panel widened to be continuous along the curb line.

All curb ramps shall include tactile walking surface indicator plates (truncated dome type) which conform to the most recent versions of OPSS 351 and OPSD 310.039. Tactile walking surface indicators shall be set to final elevation according to the manufacturer's instructions. The lip between the concrete sidewalk surface and the tactile walking surface indicator plate shall not exceed 3.0 mm at any point.

Curb and sidewalk shall be extended across commercial and industrial entrances unless the entrance is signalized or is aligned with a municipal street on the opposite side of the street.

Curb cuts in commercial and industrial areas shall be in accordance with OPSD 350.010.

9.3.8 Sidewalks

The requirements for a 1.5 m metre wide concrete sidewalk on one side of all local streets, and on both sides of the street for collector and arterial streets shall be confirmed with the Town. Sidewalks shall be constructed in the locations shown on the typical road cross-sections.

The requirements for Pedestrian Walkways will be reviewed with the Developer at the time of Draft Plan approval. The standards for the walkway will be reviewed on an individual basis considering the use and maintenance requirements.

A maximum sidewalk grade of 7% and a maximum crossfall of 4% will be permitted. However, the designer should strive to limit the grade to no more than 5% and the crossfall to 2%, where possible.

Sidewalk construction shall be in accordance with OPSD 310.010.

All sidewalk is to be constructed on a properly compacted foundation of a minimum of 150mm of Granular 'A' or approved equivalent compacted to a minimum of 98% Standard Proctor Density.

All sidewalks must have a minimum offset of 1.0m from edge of sidewalk to the side slope of the roadside ditch.

Concrete sidewalk shall be in accordance with OPSS 351, all concrete shall be supplied in accordance with the "Performance Specification Alternative" of OPSS.MUNI 1350 and shall meet the requirements of CSA A23.1, Exposure Class C-2, with a minimum compressive strength of 32 MPa at twenty-eight (28) days.

Concrete sidewalk ramps shall be installed as per OPSD 310.030, 310.031, or 310.033, where applicable and OPSD 310.039 regarding tactile walking surfaces.

At the discretion of the Town, wider sidewalks (1.8 m or greater) may also be requested to accommodate large pedestrian volumes or shopping carts, etc.

9.3.9 Grading within Right-of-Way

The boulevard area from the curb to the property line shall be graded to provide positive drainage toward the roadway at a minimum of 2% and a maximum of 8%.

For roads having a rural design cross-section (i.e. estate residential or industrial), the area between the edge of the road shoulder and the street line shall be graded and the ditches cut with slopes of 3.0 m horizontal to 1.0 m vertical from the edge of the shoulder to the bottom of the ditch and from the bottom of the ditch to the original ground. In fill areas over 1.5 m measured vertically from the edge of shoulder to the toe of slope, the fill slope shall not be steeper than 2:1. The ditch shall be located at the toe of the fill slope.

The height of sod located between the back of curb and the "forward" edge of the sidewalk should be installed at an elevation equal to or slightly less than the sidewalk surface.

In areas where erosion control is required, aesthetically pleasing options such as reinforced sod are to be used rather than rip-rap, where possible.

9.3.10 Road Crossing and Entrance Culverts

The minimum sizes for entrance and road crossing culverts are 400 mm and 500 mm, respectively.

The conveyance capacity of the culvert must be sufficient to ensure that the maximum depth of ponding as indicated in [Table 17](#): "Maximum Allowable Flow Depths" is not exceeded.

Where the conveyance capacity of the minimum size culvert is not sufficient, a larger diameter culvert is to be sized using the cross-sectional end area calculated by the rational design method. Detail drawings and calculations shall be submitted for approval by the Town.

The minimum length of road crossing culvert shall be that which is required to extend from centre of ditch to centre of ditch with matching slopes not exceeding 3:1.

The minimum length of entrance culverts shall depend on the width of the entrance but shall extend at least 1.5m on either side of the entrance.

Headwalls or end treatments will only be permitted where a 3:1 slope cannot be achieved. Because the use of headwalls or end treatments will only be permitted in exceptional circumstances, their design must be approved by the Town on a case by case basis.

The minimum depth of cover for all culverts is 300 mm unless otherwise indicated by the Town.

Culverts shall be constructed with granular bedding and backfill in accordance with OPSD 802.014 or 802.034.

9.4 DRIVEWAY AND ENTRANCE DESIGN

9.4.1 Geometry

Urban Residential Entrance Design shall be per Ontario Provincial Standards OPSD- 351.010.

Urban Industrial, Commercial and Apartment Entrance shall follow Ontario Provincial Standards OPSD 350.010.

Rural Entrance Design shall be per OPSD 301.010, 020, and 030.

9.4.2 Location

All residential driveways shall be located in accordance with the setbacks as identified in the Zoning By-law. On corner residential lots, the edge of driveway is to be a minimum of 4.5 m from the end of the daylight triangle.

Non-residential entrances shall not be located within 15.0 m of any intersection. On rural roadways, the end of the driveway culvert shall not be closer than 1.5 m from the extension of the side yard property line.

9.4.3 Grades

The maximum grade for driveways and entrances shall be 8% except in site-specific cases with written approval from the Town. This maximum grade is not recommended and should be employed only in exceptional cases where conditions prohibit the use of lesser grades. The minimum grade permitted is 1%. Maximum grade change shall be 4% at curb or sidewalk.

9.4.4 Width

For a residential driveway, the minimum width is 3.0 m and the maximum width shall be equal to 60% of the lot frontage to a maximum of 9.0 m between the street line and the curb line. For a non-residential and high-density residential, two-way entrance, the minimum width is 7.0 m measured at street line. Site-specific zoning regulations apply.

9.4.5 Pavement Structure

For residential driveways, between the back of curb and property line, the driveway entrance shall have a minimum of 150 mm of Granular 'A' and 50 mm HL3 surface asphalt or another hard surface as approved by the Town. For non-residential entrances, the minimum pavement structure shall be 300 mm of Granular 'B', 150 mm of Granular 'A', 50 mm HL4, and 40 mm HL3.

For fire routes, the minimum pavement structure shall be 450 mm of Granular 'B', 150 mm Granular 'A', 80 mm HL8 and 40 mm HL3. A more stringent pavement structure may be required and must be confirmed by the Geotechnical Engineer. A lesser pavement structure, with a single lift of asphalt, may be considered for general parking areas outside of the fire route, with consideration for delivery vehicle needs.

9.4.6 Driveway Edging

For residential driveways, raised edging using concrete curbing or other materials along the sides of the driveway is not permitted within the Town road allowance, but may be constructed on private property.

9.4.7 Driveway Pairing

Driveway pairing shall only be used in intensification areas (semi-detached, townhouse developments) and downtown business areas.

9.5 WALKWAYS & TRAILS

It is recommended the requirements for walkways be discussed with the Town prior to commencing the engineering design. The following provides general requirements for typical walkways.

9.5.1 Bicycle Lanes & Multi-Use Trails

In all circumstances bicycle lanes and multi-use trails shall be implemented in accordance with the Town's Active Transportation Master Plan and Active Transportation Strategy.

The requirements for bicycle lanes and multi-use trails are to be discussed at the planning stage and within the Traffic Impact Study (if one is required). The designer shall confirm with the Town

if there will be any requirements for the provision of bicycle lanes or multi-use prior to the commencement of the engineering design.

In general, on any road where the average daily traffic volumes in one direction of travel exceed 5,000 vehicles, bicycle lanes or multi-use trail(s) must be provided. This can be accomplished by providing an exclusive 1.5 m wide bicycle lane on both sides of the road or by providing a minimum 3.0 m multi-use trail on one side of the road. All bicycle infrastructure whether on the road or off the road shall be in accordance with Ontario Traffic Manual Book 18.

For Major Collector or Arterial Roads with average daily traffic volumes less than 5,000 vehicles in one direction, the Town may still require the provision of bicycle lanes.

Dedicated bicycle lanes are generally not required on Local Roads.

The design for the bicycle lanes shall be in accordance with the Transportation Association of Canada (TAC) Urban Supplement to the Geometric Design Guide for Canadian Roads.

The Regional Municipality of Halton Active Transportation Master Plan includes a design toolbox which may be utilities as a supplemental design reference (<https://www.halton.ca/For-Residents/Roads-Construction/Infrastructure-Master-Plans/Active-Transportation-Master-Plan/Appendix-G-AT-Design-Toolbox>).

9.5.2 Pedestrian Walkways and Park Maintenance Pathways

Where the walkway block is to serve only pedestrians or where it is to be used as an entrance to an Open Space Block or Park Area and may be used by maintenance equipment, the walkway is to be 3.0 m wide with a 1.5 m high chain link fence along each side of the walkway block. The walkway shall be concrete for the full 3.0 m width with no crown or reverse crown. In general, the sidewalk standards under Section 9.3.8 shall apply. No bollards or entrance gates will be required at street line.

9.5.3 Walkway/Service Corridor

Where the walkway block also incorporates watermains, sanitary sewers, or storm sewers, it shall have a minimum width of:

- 9 metres for one sewer (sewer centered on the easement);
- 12 metres for dual sewer installation;
- 6 metres for a watermain (watermain centered on the easement);
- 10 metres for one sewer with a watermain (3m easement limit to watermain, 2.5m clearance between watermain and sewer and 4.5m sewer to easement); and

- 12 metres for dual sewer installation with a watermain.

The above easement widths are minimum requirements and may be increased depending on the depth and size of the pipes within the easement and/or soil conditions, topography, or operational needs.

The corridor shall have a 1.5m high chain link fence along each side. It shall include a 3.0m wide concrete walkway and landscape strips along each side.

The depth of the services beneath the walkway is to be approved by the Town. If excavation for maintenance would impact on the footings of adjacent homes or buildings, then an easement is to be provided adjacent to the walkway or the footings of those buildings is to be extended or a combination of the two (2) measures. This impact will be assessed by a qualified geotechnical engineer and the proposed solution described in the “Geotechnical Report”.

The spacing of the trunk services shall also be considered and, if necessary, the walkway block is to be widened to accommodate all services. The horizontal separation of services is to meet the recommendations of the MECP and the centreline of the service must not be closer than 1.5 m from the limit of the walkway block.

9.5.4 SWM Pond Maintenance Access/Walkway

Where the walkway is intended to be used by pedestrians but the main objective is for maintenance access to SWM pond features such as sediment forebays, spillways, or outlet structures, the access/walkway from the street into the facility is to be 8.0 m wide, including a 4.0 m wide asphalt surface equivalent to that of a local street, including granular base, or other hard surface as approved by the Town, and a 2.0 m wide landscaped strip will be provided along each side. Once inside the facility, the access/walkway width is to remain at 4.0 m and a 6.0 m buffer strip is to be provided between the access/walkway and private property.

A pedestrian access gate shall be provided at street line.

The minimum and maximum grades permitted for walkways are 0.5% and 3.0%, respectively except the portion of the access/walkway in a SWM Facility that extends down into the forebay. A maximum grade of 10% can be used for this purpose.

9.5.5 Fencing

Standard 1.5 m galvanized chain link fence with top rail shall be placed along all walkways, steep slopes, adjacent to commercial properties, between stormwater management facilities, and private property, and elsewhere as required by the Town. Fencing of 1.2m height will be considered on a case by case basis.

Standard 1.8 m galvanized chain link fence with top rail shall be placed adjacent to institutional properties, open spaces, and in parks. The mesh shall be placed facing Town property.

The Town will require that a 1.8 m high wood privacy fence be installed between development property/lots and existing residential properties, between residential and agricultural, between residential and commercial properties, between residential and institutional properties, or between commercial and institutional properties. Where the residential lot is fronting on travelled road the wood fences must terminate at the front line of the house, and if fencing is required, continue to the front property line as a chain link fence (maximum height of 1.2m) so that it does not impact the visibility of the front yard to drivers.

Gates for access from private property to municipal or EA property are not permitted to be installed in any fence. Further, no gates shall be permitted in an acoustical fence, unless written approval is received from the Town.

The requirement for, location, and extent of acoustical fence shall be defined in the noise and vibration study and must be approved by the Town. The maximum height of acoustical fence shall be 2.15m, or as approved by the Town. If the noise and vibration study conclude that additional height must be added to the acoustical fence to achieve the required noise levels, this must be accomplished by installing the fence atop a berm. Acoustical fences that are maintained, repaired, and replaced by the Town shall require a minimum 2.0 metre easement for Town's access.

Where an open space block, park, or stormwater management facility is adjacent to a municipal road allowance, a fence will not be required unless necessary as part of a park development plan or as a result of slopes in excess of 3H:1V.

Generally, fences are to be placed at a 0.15 m offset from the common property line on the development property side, unless otherwise approved by the Town. Refer to OPSD 972.130 for general chain link fence details.

In rural areas, and only where written approval is received from the Town, the installation of highway fence (farm fence) as per OPSD 971.101 and OPSS.MUNI 771 may be permitted.

9.6 SIGNS AND PAVEMENT MARKINGS

Street Name and Traffic Control signs are to be in accordance with Transportation Association of Canada (TAC). recommended standards.

9.6.1 Street Name Signs

Double unit street name signs of an approved design, green in colour (high intensity Scotchlite grade) with high intensity white Highway Gothic lettering, shall be erected on 3.6 m "U-Channel"

galvanized steel posts or 4x4" (89x89 mm) pressure treated wood posts, embedded 0.9 m in the ground.

9.6.2 Traffic Signs

Signs of the standard type approved by the Ontario Ministry of Transportation Ontario Traffic Manual shall be mounted on 3.6 m "U-Channel" galvanized steel posts or 4x4" (89x89 mm) pressure treated wood posts, embedded 0.9 m in the ground.

9.6.3 Pavement Markings

Upon completion of the final asphalt and upon notification by the Town, pavement markings shall be painted conforming with the Standards of the Ontario Ministry of Transportation, Ontario Traffic Manual Book 11 (Pavement, Hazard and Delineation Markings) at all intersections, school crossings, walkways, bike lanes and railway crossings to clearly indicate the proper traffic zones, lanes and stop lines.

Lane markings are to be organic, solvent-based, or water borne traffic paint complete with glass beads. All lane marking applications to new asphalt require two applications of paint. The second application shall not be applied until the first is tack free. Pavement markings are to conform to OPSS 710 and OPSS 1712.

Traffic lane symbols, stop bars and pedestrian crosswalks are to be durable pavement markings or field reacted polymeric pavement markings in accordance with OPSS 710, OPSS 1713, and OPSS 1714.

All pavement marking removal required to prepare the area for final pavement marking shall be done by abrasion.

Local streets do not require centreline pavement marking, but stop bars are required with a minimum of 15.0 m of centreline marking.

9.6.4 Bicycle Lanes

The designer shall confirm with the Town if there will be any requirements for the provision of bicycle lane at the planning stage.

The design for the bicycle lane pavement markings shall be in accordance with the Transportation Association of Canada (TAC) Urban Supplement to the Geometric Design Guide for Canadian Roads.

The Regional Municipality of Halton Active Transportation Master Plan includes a design toolbox which may be utilities as a supplemental design reference (<https://www.halton.ca/For->

[Residents/Roads-Construction/Infrastructure-Master-Plans/Active-Transportation-Master-Plan/Appendix-G-AT-Design-Toolbox](#)).

9.7 OTHER SITE PLAN CONSIDERATIONS

9.7.1 Parking Design

When designing the layout of parking lots, the designer shall consider the turning requirements for delivery vehicles and emergency vehicle access. They should also take into account queue development at the entrance, pedestrian flow through the parking area, and dropped curb with ramps at convenient locations for wheelchair accessibility.

For high intensity traffic queueing businesss with drive-thru features a vehicle queue plan and traffic movement plan shall be prepared.

The designer shall meet the parking requirements identified in the Town Zoning By-law (<https://www.erin.ca/media/2991/1-zoning-by-law-07-67-updated-oct-2021.pdf>) and the Town of Erin Community & Architectural Design Guidelines (<https://www.erin.ca/media/2735/20210413erinudgsmall.pdf>) as well as setbacks from property line.

9.7.2 Grading

The grading of parking areas should not be less than 0.5% and not more than 5.0% with 1.0% preferred. Grades perpendicular to parked vehicles should not exceed 4%. The grading shall provide for an overland flow route to an adequate drainage outlet without exceeding a ponding depth of 0.3 m anywhere on the parking lot.

9.7.3 Parking Spaces

The standard perpendicular to the direction of traffic parking space dimensions is 6.0 m long by 3.0 m wide with 6.0 m wide laneways between rows of parking for two-way traffic and 4.0 m wide laneways for one-way traffic, subject to any approved changes to the Town's Zoning By-law. The 6.0 m parking stall length can be reduced to 5.7 m if there is suitable overhang at the curb line. The parallel parking stalls shall be a minimum of 7.0 m long and 2.75 m wide (excluding the width of the gutter).

Barrier-free parking spaces are to be provided at a ratio of 1:30. Where the application of this ratio results in a fraction of a parking space, the required number of spaces shall be increased to the next whole number. Each space is to be 3.0 m wide with a 1.5 m access aisle. All barrier-free parking spaces are to be signed with the accessible parking symbol painted on the asphalt of each space and with the By-Law sign posted in front of each space.

All access ramps to sidewalks shall be located so that they are in line with the access aisle and not obstructed by any parking space.

Parking spaces are to be delineated with 0.1 m wide yellow paint lines.

9.7.4 Layout

The parking lot layout shall provide an area for snow storage that does not impact accessible parking; does not reduce the total parking spaces by more than 5%; and has consideration for the features of the landscaping plan.

Where monolithic curb and sidewalk is used in a parking area, the minimum width of the sidewalk is to be increased to 1.8 m if a car bumper may overhang the curb.

9.7.5 Security and Lighting

Parking areas are to be located in highly visible areas of the site. For illumination of parking spaces, aisles, and driveways, the lighting shall be arranged to divert the light away from adjacent properties and streets and shall be downcast.

Refer to Section 11 for additional lighting design details.

9.7.6 Fire Routes

A 6.0 m wide fire route with a clear radii of 9.0 m (inside), 12.0 m (centreline), and 15.0 m (outside). The fire route is to be signed and no parking signs installed as required.

The fire route must also be designed to meet any and all requirements under the Ontario Building Code.

The fire route design is subject to approval by the Town and the Fire Department.

9.7.7 Landscaping

All landscape plans shall be prepared by an accredited professional Landscape Architect in good standing with the Ontario Association of Landscape Architects (OALA). The Landscape Architect shall coordinate and liaise with all other consulting professionals to ensure accurate representation of the site and the proposed development.

Existing vegetation should be incorporated where grading, drainage, and species allow for continued health of the vegetation. Existing vegetation which provides screening between residential areas and commercial/industrial/institutional and collector/arterial roads should be prioritized for retention. All healthy perimeter trees, defined as those immediately on the shared property boundary or on adjacent property with a canopy overhanging the property boundary,

must be protected, unless written approval is provided by adjacent landowners for removal or unless it is deemed to be a road safety issue by the Town.

Landscaping shall be provided for the control of noise, wind, erosion, glare, and aesthetics. Natural features such as trees should be preserved and incorporated as much as possible into the design.

9.8 SCHEDULING OF WORK

The contractor shall provide the Town with a detailed work schedule prior to the start of construction.

The schedule should include all major project tasks, start date & task duration, and updates should be provided to the Town regularly, and during any significant scheduling changes. The schedule should also reference any project restrictions including; but not limited to, Reduced Load Periods, preventing unnecessary disruption to public traffic, deadlines for temperature sensitive work such as hot mix asphalt paving and concrete placement, etc.

The contractor shall schedule temporary restoration of the roadway to follow closely behind trench backfilling. Unless otherwise noted, permanent restoration may be delayed until all trenching has been completed.

All work should be scheduled in a way that excavations are not left open when adjacent to, or on an open lane of traffic at night, or when work is inactive.

9.9 MAINTENANCE

The contractor is responsible for maintenance of all Services in order to ensure the safety of vehicle traffic and pedestrians during construction, as well as during the maintenance period outlined in the contract.

In this section a Service is defined as; roads, curbs, gutters, sidewalks, buried infrastructure, drainage works, lighting, landscaping, erosion and sediment control measures, and any other works outlined in the project contract or plans and specifications.

Maintaining Services includes but is not limited to the following:

- Rectify, replace, or repair any Service not constructed in accordance with the approved plans and specifications.
- Maintain roads in a mud and dust free condition and free of debris and obstructions.
- Ramp all maintenance holes and catch basins with hot mix asphalt as required.

- Maintain adequate and safe traffic control measures to ensure the safety of workers, vehicles and pedestrians.

9.10 MATERIAL SPECIFICATIONS

9.10.1 Granular Materials & Soils

The requirements of OPSS.MUNI 1010 shall apply for all granular material used to construct, restore, and maintain roadways and driveways except where amended herein.

The contractor shall provide to the Town the confirmed source of granular material or materials, a minimum of two weeks prior to construction. A sample of each material should be obtained and tested in order to confirm conformance with the contract and plans and specifications.

9.10.2 Granular A

OPSS.MUNI 1010.05.02 – produced by:

- a) Crushing quarried bedrock (100% crushed).
- b) Crushing quarried bedrock (100% crushed) including Reclaimed Asphalt Pavement (RAP) up to 30% by mass.

Granular A produced from naturally deposited sand, gravel, and cobbles may be permitted subject to permission by the Town.

9.10.3 Granular B

OPSS.MUNI 1010.05.03 – Type II produced by crushing quarried bedrock (100% crushed).

Granular B Type I produced from naturally deposited sand, gravel, and cobbles, or quarried bedrock may be permitted subject to permission by the Town.

9.10.4 Recycled Materials

Town may permit the use of granular materials produced from Reclaimed Concrete Material (RCM). RCM may contain RAP up to a maximum of 30% by mass. Prior to using materials that contain RAP, QC/QA samples shall be obtained to determine the amount of asphalt-coated particles using MTO Test Method LS-621.

Granular material shall not contain more than a combined total of 0.5% by mass of deleterious material. Deleterious materials include but are not limited to, wood, clay, brick, clay tile, gypsum, gypsum plaster, and wallboard.

9.10.5 Testing and Sampling

The contractor must provide the source of granular materials no later than two weeks prior to the start of construction. The contractor will be responsible for Quality Control (QC) testing unless otherwise noted in the contract documents. The Town may retain a Materials Testing & Inspection firm to conduct regular sampling and Quality Assurance (QA) testing on all materials from both the source, and project sites. Granular material shall be sampled and tested to confirm gradation, as well as the Maximum Dry Density, and Optimum Moisture Content at a minimum frequency of one sample for every 1,000 tonne of material placed, unless otherwise approved by the Town. Additional sampling and testing may be required due to changes to the supplier, or inconsistency of the imported material.

Sampling procedures shall be in accordance with the Ministry of Transportation Laboratory Testing Manual, Test Method LS-625 Guidelines for Sampling of Aggregate Materials.

Testing procedures should conform to the Ministry of Transportation Laboratory Testing Manual and / or the applicable CSA, ASTM, or AASHTO specifications.

9.10.6 Hot Mix Asphalt

The requirements of OPSS.MUNI 1150 and OPSS.MUNI 1151 shall apply to Hot Mix Asphalt (HMA) materials used to construct, restore, and maintain roadways and driveways except where amended herein.

The contractor shall provide the Town with the confirmed source of hot mix asphalt materials a minimum of two weeks prior to construction. A sample of each material should be obtained and tested to confirm conformance with the contract, plans and specifications.

9.10.7 Asphalt Cement

Performance Graded Asphalt Cement (PGAC) shall be supplied from an MTO Designated Source for Materials supplier and meet the requirements of OPSS.MUNI 1101 as amended herein.

Asphalt cement shall meet the Performance Grade PGAC 58-34 for local and collector streets, as well as non-commercial driveways.

Asphalt cement shall meet the Performance Grade PGAC 64-34 for arterial and industrial roads, as well as commercial driveways.

9.10.8 Asphalt Aggregates

Asphalt aggregates shall conform to OPSS.MUNI 1001 and OPSS.MUNI 1003. The use of steel slag or blast furnace slag in asphalt mixtures is not permitted.

9.10.9 Asphalt Mix Designs

Mix designs shall be completed in accordance with OPSS.MUNI 1150 and OPSS.MUNI 1151.

Mix designs shall be submitted to the Town a minimum of two weeks prior to the start of paving. Unless otherwise stated in the contract documents, the mix design submission shall include, at a minimum, the following:

- a) A letter from the project Geotechnical or Materials Engineer confirming that the proposed mix conforms to the Town specifications.
- b) All documents listed in OPSS.MUNI 1150.04.02.03 and OPSS.MUNI 1151.04.05.
- c) Laboratory testing results that confirm the physical and Superpave consensus properties of the aggregates are in conformance with OPSS.MUNI 1001 and OPSS.MUNI 1003, except as amended in this document.
- d) If RAP is used, confirmation of the average asphalt cement percentage, equivalent and average gradation from RAP using Test Method LS-282 or LS-292 of the Ministry of Transportation Laboratory Testing Manual.

9.10.10 Asphalt QA/QC Testing

The requirements of OPSS.MUNI 310, OPSS.MUNI 1150, and OPSS.MUNI 1151 for Hot Mix Asphalt sampling and testing shall apply except where amended herein.

The contractor shall, upon request, allow the Town, contract administrator or their representatives to enter upon the premises of any of the material manufacturers, suppliers, plants, laboratories, or equipment for purposes pertaining to the work, to carry out such inspection, sampling and testing as specified or requested by the Town, contract administrator or their representatives.

Frequency of HMA sampling shall be in accordance with OPSS.MUNI 310 Table 6.

Samples of loose HMA shall be obtained using sampling plates. The QA/QC technician shall obtain at least three equal increments of HMA, selected at random, and combine to form a field sample that weighs a minimum of 10 kg for Marshall mixes, and a minimum of 20 kg for Superpave mixes. This process shall be repeated for each sample taken.

Samples shall be tested by a Canadian Council of Independent Laboratories (CCIL) certified laboratory to confirm that the HMA conforms to the specifications;

- a) For Marshall mixes, samples shall be used to determine compliance of asphalt cement content, aggregate gradation, air voids, flow, voids in mineral aggregate, and stability requirements.

- b) For Superpave mixes, samples shall be used to determine compliance of asphalt cement content, aggregate gradation, and Superpave mix properties in accordance to AASHTO M323.

9.10.11 Concrete

The requirements of OPSS.MUNI 1350 shall apply to ready mixed concrete materials used to construct, restore, and maintain any concrete object located within Town property or R.O.W. including but not limited to curb, sidewalk, and structures.

The contractor shall provide to the Town with the confirmed ready mixed concrete supplier a minimum of two weeks prior to construction.

Concrete suppliers shall provide a valid Certificate of Ready Mixed Concrete Production Facilities as issued by the Ready Mixed Concrete Association of Ontario (RMCAO).

9.10.12 Concrete Mix Design

Mix designs shall be submitted to the Town a minimum of two weeks prior to concrete placement. The mix design submission shall include the following:

- a) A valid Certificate of Ready Mixed Concrete Production Facilities as issued by the Ready Mixed Concrete Association of Ontario (RMCAO).
- b) A summary of all materials, and sources used in each mix including, but not limited to; cement, supplementary cementing materials (slag, fly ash), coarse and fine aggregate, water, chemical admixtures, and air entrainment.
- c) A certificate or letter verifying the compatibility of the admixtures to be used in the concrete, if admixtures are supplied from different manufacturers.
- d) Target air content (%) and slump range (mm).

The Town may request additional documentation of the materials used in any concrete mixture before placement, or any time during the maintenance period. When requested in writing from the Town, the contractor shall supply testing results that confirm the gradation, physical requirements, and scaling resistance of the materials conform to OPSS.MUNI 1002.

Only ground granulated blast furnace slag (Type S) is permitted, up to a maximum of 25% in any concrete mix.

The use of slag is not permitted if the air temperature is 28°C or higher at the time of placement or forecasted to be 28°C or higher within 24 hours after placement. The use of slag is not permitted if the air temperature is at or below 5°C at the time of placement or forecasted to be at or below 5°C within 96 hours after placement.

9.10.13 Concrete QC/QA Testing

Concrete sampling and testing should be in accordance with CSA A23.1:19/CSA A23.2:19 - Concrete Materials and Methods of Concrete Construction/Test Methods and Standard Practices for Concrete. QC/QA sampling and testing shall only be performed by a Canadian Council of Independent Laboratories (CCIL) certified technician. Laboratory testing shall only be completed by a CCIL certified lab.

The contractor shall arrange for on-site quality control testing which shall conform to the minimum frequencies below:

- a) Compressive Strength - Not less than one set of three cylinders for every 100 m³ of concrete placed, with no less than one test for each class of concrete placed on any one day.
- b) Slump - Not less than the first five loads per mix per day, plus one test for every air test that is completed.
- c) Air Content - All concrete mixes should be tested for air content (whether air entrained or not). For classes C-2, C-1 and C-XL, the first five consecutive loads shall be tested to confirm consistency. Thereafter, testing may be performed every third load.
- d) Temperature - Temperature readings should be recorded every time a sample is taken for any of the aforementioned testing requirements. Temperature should be recorded to the nearest 0.5°C.

9.11 ROADWAY CONSTRUCTION

The contractor shall construct all Town roadways and driveways in accordance to the specifications in this section. This section contains amendments to the OPSS and should be read carefully to ensure compliance during construction.

9.11.1 Grading

Grading shall conform to OPSS.MUNI 206 except where amended herein.

Grading shall conform to the **TOESD**, and project drawings and specifications.

Grading tolerances are as follows:

- a) Subgrade / Trench Backfill +/- 30mm of proposed elevation.
- b) Granular Subbase (Granular B) +/- 20mm of proposed elevation.
- c) Granular Base (Granular A) +/- 10mm of proposed elevation.

9.11.2 Subgrade Preparation and Trench Backfilling

The use of site excavated inorganic soil is generally acceptable for use as a trench backfill, providing:

- a) Backfilling operations are carried out in conformance with the requirements of OPSS.MUNI 401, using earth compacting equipment of appropriate type, size, and weight;
- b) The minimum compacted density within 1.0 metre of the final subgrade is to be compacted to 98% of the Standard Proctor Maximum Dry Density (SPMDD), with in-situ moisture content within 2% of the optimum value; and,
- c) During construction, a geotechnical consultant must inspect the condition of the roadway subgrade and the installation of pipe bedding/embedment and the backfilling of trenches.

The Geotechnical Consultant is to certify that they, or their designate, have conducted a sufficient number of tests to obtain a comprehensive summary of the degree of compaction achieved, and that all works were constructed in accordance with OPS.MUNI 401.

The Town requires compaction testes are performed on every fill layer, roadway subgrade, granular subbase and base, and asphalt layers. As a minimum, one compaction test on every lateral service trenches is required. Fill layers placed shall not exceed 300 mm in thickness (loose).

Prior to placing granular materials, the road subgrade shall be proof rolled to the satisfaction of the Town and geotechnical engineer.

The subgrade shall be shaped to conform to the required longitudinal grade and cross-section and shall have a cross-fall of 3% from the centreline of roadway to each side unless otherwise approved by the Town. If considered necessary by the Town, the subgrade shall be recompacted with suitable mechanical compaction equipment as required to produce a solid base for the road granular.

9.11.3 Road Subdrains

Continuous Sub-Drains on both sides of the road shall be installed if required in the geotechnical report.

Subdrains shall be a minimum of 100 mm diameter and installed as per OPSS.MUNI 405.

In general, the subdrains are to be connected to catch basins. When a subdrain is extended to discharge above grade, the last 3.0 m section shall be rigid pipe with a rodent grate and marker provided.

9.11.4 Placing Granular Materials

The requirements of OPSS.MUNI 314 shall apply for the placement of granular material except where amended herein.

The requirements of OPSS.MUNI 501 shall apply for compaction except where amended herein.

Granular materials shall only be placed on a properly prepared subgrade that has been inspected and approved by the geotechnical engineer and the Town. Prior to placing granular material, the contract administrator shall confirm that the prepared subgrade meets the aforementioned grading tolerances.

Remove and replace any areas where the materials have become segregated prior to compacting. For roadway subbase construction, lift thickness shall not exceed 300 mm. For roadway base construction, lift thickness shall not exceed 150 mm.

Granular material shall be compacted to 100% SPMDD, unless otherwise specified in the approved plans and specifications.

9.11.5 Asphalt Pavement Construction

The requirements of OPSS.MUNI 310 shall apply for constructing, repairing, or replacing hot mix asphalt pavements except where amended herein.

Saw cut existing asphalt full depth in neat, consistent, parallel lines and at 90° angles. Diagonal or meandering cuts are not permitted. Ensure saw cut edges are clean and vertical.

All abutting edges of existing pavement shall be prepared and coated with tack coat prior to placement of new asphalt. Tack coat shall be placed by the use of a mechanical (pump driven) spray wand that is capable of being heated for cold weather operation and applying the tack coat in a consistent uniform application. All longitudinal joints and transverse joints shall be tackcoated prior to placement of the adjacent pass of asphalt. No asphalt shall be placed on the tack-coated surface until the tack coat has cured.

Any joint cracking occurring within the Warranty Period shall be deemed to be a deficiency.

Longitudinal joints in the surface course shall be parallel to the demarcation between the driving lanes (i.e. line paint), wherever feasible, at an offset of 100 mm to 150 mm from the centerline of the demarcation (approximately 1.5 m away from the inner wheel path). The joint shall not be placed in the wheel paths.

After final compaction, each course of HMA shall be of uniform texture and shall be free of segregation, fat spots, oil spills or any other defects. Defective areas shall be removed and replaced with acceptable hot mix of the same type and compacted to the satisfaction of the Town.

Compaction testing of the placed HMA shall meet the requirements of OPSS.MUNI 310 Table 10.

9.11.6 Gravel Surfaces

Gravel surfaces shall be constructed and restored as shown on the Contract Documents.

10 Lot Grading and Drainage

10.1 GENERAL

The grading and drainage design, whether it is being prepared for an individual lot, small site, or entire development, should be completed with the following objectives:

- to provide positive drainage and maximize the use of land while minimizing maintenance requirements;
- to complement the land and suit the type of structure that is to be constructed;
- to accommodate runoff from adjacent lands and to ensure that the adjacent and downstream properties are not adversely affected;
- to minimize the perimeter disturbance and preserve existing trees, where required; and
- to minimize the use of rear lot catchbasins and retaining walls.

Where the overall grading of an area, such as a park or townhouse block, cannot be completed until after the area is fully developed, for example in the case of a phased development, the designer will be required to develop an interim grading and drainage design for that area, to the satisfaction of the Town.

The Developer will be required to grade the lots to within 0.3 m of the final grade within the building envelope, primary tile bed area, and driveway as specified on the approved grading plan as part of the servicing requirements. The balance of the lands shall be graded to final grade, topsoiled and seeded/sodded as part of the servicing requirements.

All drainage swales and lot drainage outside of the above noted areas shall be established prior to the Town granting Preliminary Acceptance. The topsoil shall be stripped from all cut and fill areas and stockpiled for reuse during final grading operations. Should there be a deficiency in suitable on-site fill material to grade the lands, the Developer shall import clean suitable fill meeting the requirements of MECP Table 2 to grade the lands in accordance with the above requirements. The topsoil shall be left on site until such times as the building and grading operations are completed at which time any excess topsoil can be removed by the Developer.

Where the overall grading of an area, such as a park or townhouse block, cannot be completed until after the area is fully developed, for example in the case of a phased development, the designer will be required to develop an interim grading and drainage design for that area, to the satisfaction of the Town.

10.1.1 General Grading

For residential lots and blocks, it is preferable to have one consistent slope of between 2% - 6% for the entire rear yard area; however, where this is not possible, lots are to be provided with a rear yard amenity area in which a slope of between 2% - 5% is provided for a minimum of 5.0 m from the rear of the house. The Town will allow 1% slope at a minimum of 5 m away from building to encourage LID engineering design.

All other areas shall have a minimum slope of 1% and a maximum slope of 3:1, to a maximum of 3 m horizontal distance before a 6% slope is Provided.

Where retaining walls are required, they are to be designed by a Professional Engineer in accordance with O.B.C.

Any lot with a 10% average grade may require a split-level dwelling and cross sections may be required.

All regional flood and fill lines must be indicated on lot grading plans where developments are adjacent to existing water courses.

10.1.2 Swales

All swales are to be designed with a minimum slope equal to or exceeding 2.0% and a maximum slope of 6.0% with maximum side slopes of 3:1. If a slope equal to or exceeding 2.0% cannot be met due to grading constraints, a minimum of 1.0% can be considered if a perforated subdrain of 100mm in diameter covered in 19mm clear stone and wrapped in filter cloth is provided beneath the swale to reduce surface ponding. The subdrain must outlet to grade or a catchbasin.

All swales shall have a minimum depth of 0.15 m. The maximum depth for side yard and rear yard swales shall be 0.3 m and 0.45 m respectively.

The maximum contributing area to a side yard swale shall be 500 m². For rear yard swales, the maximum contributing area shall be 1,000 m² and the maximum length shall be 60 m. The flows from the contributing areas should be calculated and the capacity of the swale confirmed to ensure adequate conveyance.

10.1.3 Rear Yard Catchbasins

Rear yard catchbasins are discouraged and will only be considered where necessary and where all structures are protected from flooding if the inlet is blocked or surcharged by a major storm event.

Rear yard catchbasin leads can be concrete or PVC. The minimum size of the connection shall be 300 mm in diameter. Minimum slope shall be 0.5%. No inlet control devices are to be used in locations where the rear lot catchbasin is connected to the road catchbasin or the manhole.

Where the lead goes between the houses, it shall be concrete encased between front building line and rear building line.

Manholes on the mainline sewer shall be placed, where possible and applicable, at the intersection of rear lot catchbasin leads and the mainline to facilitate access to the rear lot catchbasin pipe. For locations where placement of manhole at the inlet of rear yard catchbasin lead is not possible or feasible, such lead must be connected to road catchbasin which connects to a main line (without manhole).

10.1.4 Retaining Walls

Retaining walls considered “Designated Structures” within the scope of the Ontario Building Code (OBC) will require a building permit from the Town. All other structures shall require engineering drawings stamped by a licensed professional engineer and shall conform to the following requirements.

For the purposes of this section, the height (h) of a retaining wall shall be measured from the finished ground level to the highest point of the wall and, if the height on one end of the wall is different from the height on the other end, the greater of the two shall apply.

- Retaining walls are to be constructed entirely on the upper lot so that the tiebacks, backfill, or wall system does not cross property boundaries of the lower graded lot.
- Retaining walls greater than 1.0 m in height are discouraged and will be reviewed by the Town only when the overall grading design warrants such grading differentials.
- If a retaining wall is required, a detailed drawing indicating the design, location, property line, height, tiebacks, etc. shall be submitted for approval.
- Retaining walls are not to be constructed of wood materials and must be stone with stackable connection blocks to provide an acceptable structural design.
- A minimum setback of 500 mm should be maintained from retaining wall tiebacks to the foundation of any structure. If the grading does not permit this setback, a Professional Engineer, licensed in the province of Ontario, shall provide a detailed design for Town consideration.
- All retaining walls with an exposed face height of 1.0 m or greater shall be designed and certified by a Professional Engineer, licensed in the province of Ontario. The design must be

accompanied by calculations clearly demonstrating that it is structurally satisfactory for the particular location and soil type.

- Any and all retaining walls shall have their construction certified by the Design Engineer prior to the release of grading securities and to commence the maintenance period.
- All retaining walls with an exposed face height of 1.0 m or greater shall incorporate a 1.5m high chain link fence or approved equivalent at the top. The structural stability of the retaining wall in use must be able to withstand any extra forces exerted by the fence as well as the earth loads.
- The detailed drawing shall include the following notes and illustrate:
 - Note 1: The walls have been designed in accordance with accepted engineering principles;
 - Note 2: That the wall is suitable for the geotechnical condition of the site and for the loading type;
- Weeping tile must be directed to a positive outlet;
- A filter cloth envelope surrounding the compacted free draining granular material;
- Sufficient top of wall and bottom of wall elevations;
- Type and material of wall;
- A cross-section for the length, type, and location of any tiebacks;
- Surcharge load used and appropriate design calculation; and
- A swale at the top of wall, if drainage directs to the wall.

Retaining walls higher than 1.0m

Retaining walls equal or higher than 1.0 m shall additionally include the following:

- Must be set back from the nearest property line or adjacent retaining wall a minimum distance of 0.6m;
- The Design Engineer shall be responsible for ensuring all set-back and zone of influence issues are resolved to the satisfaction of the Town;
- If adjacent to a public property access to a building, or private property to which the public is admitted, a building permit shall be required (refer to Article 1.1.2.2. (2) of the Ontario Building Code);

- Shall be designed, inspected during construction and certified by a Structural Engineer and a Geotechnical Engineer. Certification is to be submitted to the Town prior to the release of any financial securities;
- The location, type, and fastening of the 1.5m chain link fence, or approved equivalent, must meet the manufacturer's recommendations;
- Retaining walls that are maintained, repaired, and replaced by the Town shall require a minimum 2.0m easement for Town's access.

Shop drawings will be required for the retaining walls and appurtenances prior to construction. The retaining wall manufacturer and designer shall provide structural approval by a Professional Engineer licensed in Ontario to the satisfaction of the Town.

The safety fencing required for the retaining walls shall be designed with a top and bottom rail and be structurally designed by a Professional Engineer licensed in Ontario for placement on top of the retaining wall as per the retaining wall manufacturer's specifications. Material, post spacing, brace posts, and wire mesh shall be designed and approved by a structural engineer, to the satisfaction of the Town, to meet industry standards for strength and safety requirements applicable to the Development location.

10.1.5 Driveways

The preferred minimum slope on any driveway shall be 2%, however, 1% may be permitted where necessary. The preferred maximum slope for any driveway is 6%; however, 8% may be permitted where necessary.

10.1.6 Parks and Open Space

In parks or other open space areas, slopes of 2% to 5% shall be applied to provide a usable area for recreation purposes.

10.1.7 Parking Lots

The desirable surface grade for an asphalt parking lot is 1.0%; the minimum grade shall be 0.5% and the maximum grade shall be 5.0%.

10.1.8 Topsoil and Sod

The requirements in OPSS 802 & OPSS 803 shall apply except as amended herein;

Topsoil Materials

OPSS 802.05 - All topsoil shall be screened using 35mm (1 ½”) size screen. This applies to all topsoil whether acquired from the jobsite or imported from offsite. The topsoil shall be a fertile, friable natural loam containing not less than 4% of organic matter for clay loams and not less than 2% for sandy loams. Topsoil shall have an acidity value ranging from PH 6.0 to 7.5, and capable of sustaining vigorous plant growth. It shall be free of any admixtures of subsoil, clay lumps and free of stones, roots and other extraneous matter. If this is not attainable from the topsoil on site, then either this topsoil shall not be used, or it shall be mixed with imported material to attain the above-mentioned specification.

Placing Topsoil

OPSS Subsection 802.07.03 - Topsoil shall be placed to a uniform depth of 150mm. The topsoil shall be rolled with a 50kg roller for compaction. The finished topsoil surface shall be smooth and firm against footprints.

Stockpiling Topsoil

OPSS Subsection 802.07.01 is hereby amended by the addition of the following:

- Topsoil shall be salvaged and stockpiled on-site at a location approved by the Contract Administrator. Stockpiled topsoil shall be stored in mounds not greater than 6.0m in height, with the side slopes graded no steeper than 2H:1V.
- Topsoil stockpiles should be stabilized by covering with geotextile material to prevent soil erosion and contamination by weeds during storage. Where stockpiles are intended to store topsoil for periods longer than one-year, temporary ground cover vegetation composed of a non-invasive stabilizing ground cover (such as annual rye grass) will be required.
- Erosion and sediment control fencing shall be installed around all stockpiles. If deemed necessary by the Town, additional erosion and sediment control measures may be required.

Sod

OPSS 803.05.01 is hereby amended by the following:

- Sod shall be rolls of No. 1 premium grade nursery cultivated turf-grass sod, Kentucky Blue Grass/Fine Fescue.

Scheduling

Turf-grass sod shall be installed within 24 hours of delivery, and within 36 hours of harvest, unless otherwise authorized by the Town, and a suitable preservation method is approved prior to delivery.

Placement of Sod

OPSS 803.07.04 is hereby amended with the addition of the following:

- Sod shall be placed in boulevards between the sidewalk and curbs, adjacent to concrete sidewalk, abutting commercial or residential buildings, driveways and walkways, the bottom of swales and ditches, or as directed by the Contract Administrator.
- Placement of sod shall include supply, placement, pegging, rolling, watering, and maintenance as necessary.

Staking of Sod

OPSS 803.07.04 is hereby amended by the addition of following:

- Sod shall be staked on slopes steeper than 2.5H:1V and in the bottom of all swales or ditches. Sod shall be laid at right angles to slopes or the flow of water. Sodding shall start at the bottom of the slope and shall be laid crosswise and staggered on the slope. Every row shall be pegged with wooden lath pegs, of sufficient length to ensure satisfactory anchorage of the sod, and at intervals of not more than 0.5m (1.5ft.). Pegs shall be driven flush with the sod.
- Before pedestrian traffic is permitted on any staked turf, and after the turf is well rooted into the growing medium, pegs or stakes shall be removed or driven at least 5cm (2in.) below the sod surface.

Maintenance of Completed Sod

OPSS 803.07.05 is hereby amended by the following:

- Sod shall be maintained for 60 Days following completion of placement. During this period, the placed sod shall be kept healthy, actively growing, and green in leaf colour. This requirement shall be suspended during the winter dormant period defined as November 1 to April 30 inclusive.

11 Utilities, Streetlighting, and Traffic Signals

All Hydro, Telephone and other utilities shall be underground and placed in accordance with current local utility company regulations and standards.

All utility designs and layouts shall be submitted to the Town of Erin for review and approval prior to installation of any utilities.

Satisfactory evidence that the Developer has entered into an agreement providing for the installation of underground hydro and street lighting must be submitted to the Town of Erin prior to the execution of a Subdivision Agreement.

All developments shall be provided with adequate street lighting in accordance with the current requirements of the local utility companies and the Town of Erin.

Compaction of backfill for utility trenches shall be 95% Standard Proctor within boulevards and 100% for driveways and road crossings.

Design Engineer is required to prepare the Composite Utility Plans, secure approvals by all utility companies, and include in the set of Engineering Drawings being part of Subdivision Agreement. Composite Utility Plans must be available for review the latest at the 3rd submission of engineering drawings.

Utility crossings shall be 1.0m minimum horizontally and 0.25m minimum vertically from any service connection (distance is based from the outside edge of utility crossing to the outside edge of the service connection).

11.1 UTILITIES

11.1.1 Telecommunications

Telephone, cable, and fibre optic services shall be underground in locations as shown on the typical road cross-sections and shall be installed by an approved utility Contractor.

11.1.2 Hydro

Hydro service shall be underground in locations as shown on the typical road cross-sections and shall be installed by an approved Contractor.

11.1.3 Gas

Gas service shall be underground in locations as shown on the typical road cross-sections and shall be installed by an approved Contractor.

11.2 STREETLIGHTING

11.2.1 General

All roads and walkways are to be lit unless written approval is received from the Town. Streetlights shall be provided throughout all developments and may be required on roads bordering developments, if deemed necessary by the Town.

A qualified Electrical Engineering Consultant is responsible for preparing the detailed streetlight layout and design and must ensure it is in complete accordance with the Town of New Tecumseth Standards and Specifications in terms of all materials, locations, levels of lighting and absence of conflict. If the recommended levels cannot be met, the Electrical Engineering Consultant must certify the design is 'safe' and appropriate given the underlying factors. The Electrical Engineering Consultant must certify that the streetlighting design is in accordance with ESA 22/04 Regulations.

All electrical streetlight layout and design drawings, including a detailed cost estimate for the installation, shall be submitted to the Town through the Engineering Submission Package.

11.2.2 Illumination Criteria

The lighting system shall provide the average maintained light levels and meet the recommended uniformity ratios as indicated in [Table 24](#).

Table 24: Illumination Summary

| Classification | Road Allowance | Road Width | Average Illumination Level | Max to Ave Uniformity Ratio |
|---------------------------|----------------|-------------|----------------------------|-----------------------------|
| Local Residential - Urban | 20 metres | 8.5 metres | 4 Lux | 6:1 |
| Local Residential - Rural | 20 metres | 7.0 metres | 6 Lux | 6:1 |
| Local Industrial | 23 metres | 11.0 metres | 9 Lux | 3:1 |
| Minor Collector | 23 metres | 10.0 metres | 6 Lux | 4:1 |
| Major Collector | 26 metres | 11.5 metres | 13 Lux | 3:1 |
| 4 Lane Arterial | 30 metres | 15.7 metres | 17 Lux | 3:1 |
| 5 Lane Arterial | 36 metres | 19.5 metres | 17 Lux | 3:1 |

| Classification | Road Allowance | Road Width | Average Illumination Level | Max to Ave Uniformity Ratio |
|----------------|----------------|------------|----------------------------|-----------------------------|
| Walkways | - | - | 5 Lux | 6:1 |

The illumination criteria will be the prime consideration governing the lighting design for residential subdivisions and industrial roadways. Intersections shall have an illumination equal to the sum of the current design levels of the intersecting roadways. The criteria also apply where new development roads intersect with existing roads. For the purpose of photometric analysis, asphalt within the limits of the daylight corners of intersections shall constitute the intersection. A photometric point plot is required for review and approval by the Town and is to cover right-of-way from property line to property line.

The spacing of the streetlights shall be designed to ensure that the illumination criteria is maintained at all times. Particular attention may be required around bends and grade changes in the roadway. A staggered arrangement of streetlight poles (i.e. alternate location on either side of the pavement) is acceptable provided the electrical engineering consultant submits to the Town photometric calculations indicating that the minimum lighting requirements are satisfied. Where road medians are utilized, double fixtured streetlights mounted at 180° apart installed on the centreline of the median may be a feasible option to be considered by the electrical engineering consultant.

The luminaire wattages must be specified on the streetlight drawings prepared by the electrical engineering consultant and must be in accordance with the 4.3.3.

The photoelectric control (photo cell) is to be designed to automatically switch “ON” when the natural illumination decreases to 50 lux and to switch “OFF” when illumination reaches not more than 200 lux. Both operations are to be delayed 10 to 15 seconds so that the control will not respond to transient changes in lighting such as lightening flashes.

All lighting shall be designed in accordance with ANSI/IESNA RP-8-14 Roadway Lighting in a manner such that light pollution is minimized.

Parking Lots

Parking lot illumination has to address good visibility for drivers and pedestrians, provide good colour rendition for security identification, and leave sufficient impact for customer attraction.

The recommended light levels for high activity community shopping developments are:

- Average maintained illuminance level 2.0 fc (20 lux) minimum. This could be increased up to 5.0 fc (50 lux), as is common practice for current commercial developments;

- Uniformity, average to minimum 4:1.
- The minimum recommended light levels for parking lots are:
 - Minimum horizontal illuminance level 0.2 fc (2 lux);
 - Uniformity ratio, maximum to minimum 20:1.

Pedestrian Walkways

The recommended light levels for pedestrian walkways up to and surrounding any commercial buildings are:

- Average maintained illuminance level for medium activity areas 2.0 fc (20 lux) and high activity areas 4.0 fc (40 lux);
- Uniformity, average to minimum 4:1.

Site Restrictions

The recommended light levels projected onto a residential property (spill light) shall not exceed 0.1 vertical foot candles, measured line-of-site at the property line.

Light pollution, nuisance, and disability glare shall be restricted by use of full cut-off luminaries.

Pylon Signs

Externally illuminated pylon signs shall have the light source aimed downward towards the sign.

11.2.3 Light Source

The light source shall be Light Emitting Diode (LED). Minimum wattage of lights shall be 100 watts and all intersections must have a light located at the intersection with a wattage a minimum 50 watts higher than the main street wattage.

The Correlated Colour Temperature (CCT) of the LED lighting shall be between 4000K and 5000K and the Colour Rendering Index should be 70+.

11.2.4 Materials and Installation

All materials used for street lighting must be CSA approved. All materials and installation shall meet or exceed current O.P.S.S. standards, the requirements of the local utility supplier, the Town's standards and specifications, as well as the manufacturer's installation instructions. The materials and supplier shall be reviewed with the Town prior to approval and samples shall be supplied if requested.

Three types of streetlight pole assemblies are to be utilized in new subdivision developments:

Decorative Poles

Coach style lantern streetlights with decorative scroll arms mounted on a tapered, octagonal, black (midnight lace / polished), direct buried concrete pole. (Decorative streetlighting luminaires to be SDL LED by Eaton/ Cooper Lighting.). SDL fixtures to have dimming driver, universal voltage and black colour.

Standard Poles

Cobrahead style streetlights VERD VERDEON LED fixtures by Eaton with tapered elliptical aluminium arms mounted on a tapered, round, mould finished, direct buried concrete pole. (Poles to be products of USI or StressCrete). Cobrahead style fixtures to have dimming driver, universal voltage and gray colour.

Telecommunication Poles

Streetlights with internal compartments for utility service equipment to be approved by the Town on a case by case basis. (Preferred pole to be Alexander by StressCrete).

Note: The Electrical Engineering Consultant will be responsible for establishing which type of streetlight pole assembly is to be utilized, in conjunction with the Town's approval. The Electrical Engineering Consultant will review all manufacturers streetlight assembly shop drawings to ensure compliance with Town's Standards and Specifications.

Downtown Areas

For Developments within the Downtown Core and in conjunction with the Town's Approval, the following decorative pole assembly is to be utilized:

- Luminaire: F126 Series by HCI (Heritage Casting & Ironworks), black color
- Pole: P405-4F by HCI (Heritage Casting & Ironworks), black color
- Arm: A-306 Series by HCI (Heritage Casting & Ironworks), black color

All fixtures shall be dark sky compliant to minimize light pollution.

Ducts

Ducts shall be solvent welded together in trenches with minimum cover of 750 mm. Ducts shall be surrounded by 80 mm of brick sand and warning tape to cover width of trench. Road crossings to be carried out by directional bore method using thickwall PVC duct. Where open-cut road crossings are necessary, ducts shall be concrete encased. Installation as per OPSD 2100.06 and OPSS 603.

Cables

Cables to be continuous without splices and shall be installed after trenches are back-filled. Installation Specifications as per OPSS 604.

Fuses

Fuses in pole handholes as per OPSD 2255.020 and OPSS 617.

Grounding

Ground rods to be installed at power service disconnect (minimum 2 rods), at every fifth (5th) lighting pole, and at the last lighting pole in each circuit. Installation Specifications as per OPSS 609.

Power Service Disconnect

Installation Specifications as per OPSS 614.

11.2.5 Approval, Construction and Energization

Approval of electrical engineering drawings and plans for streetlighting must be obtained from the Hydro Authority during the submission process.

The entire streetlight system shall be installed in full accordance with the Electrical Safety Authority (E.S.A). The design Engineer shall certify the streetlight system design is in accordance with ESA 22/04 Regulations.

Prior to energization of the streetlight and electrical distribution system, the Developer shall schedule the E.S.A. for the inspection of the streetlight and electrical distribution system works. In addition, the Developer shall arrange for a copy of the E.S.A's "Connection Authorization" to be forwarded to the Town and arrange for the Hydro Authority to provide the Town with 48 hours notification of the intent to energize the streetlight and electrical distribution system. Energy charges with regard to the streetlighting will be paid by the Town upon energization of the streetlighting. The streetlighting system is to be energized prior to the first occupancy.

Where the Developer installs the streetlighting system, it must guarantee and maintain the lighting until assumption of the subdivision by the Town.

11.2.6 Site Plans

Lighting should be controlled by automatic switching devices such as timers or photocells. The outdoor lighting shall be reduced by 75% after normal hours of operation until dawn.

11.2.7 Lighting Configurations and Pole Offsets

All streets are to employ a staggered streetlight configuration with pole offsets from the edge of pavement as per TAC criteria or on shoulder rounding.

In urban areas behind the face of a barrier curb with design speed of 70 km/h or less, pole offsets may be reduced to 1.5 m.

In rural areas where TAC pole offsets outside the clear zone are not possible, frangible breakaway bases may be used. Frangible bases are not permitted at intersections and areas where pedestrians are expected.

Pole offsets that are identified on the Town's Typical Road Cross Sections take precedence.

Lights at signalized intersections should be combined with joint-use traffic signal poles wherever possible.

On curved roadways, the light poles should be positioned on the inside of curves, if possible. Alternatively, light poles may be placed on the outside of curves, but shall be kept out of the vehicle overrun area (the extension of the tangent in the direction of vehicle travel).

Street lights and power pedestals should be located on the extension side lot lines where possible.

Refer to [Appendix D](#) for minimum offsets for streetlights from other aboveground infrastructure.

11.3 TRAFFIC SIGNALS

Traffic signal design is to be prepared in accordance with M.T.O. Traffic Manual Book 12 and the appropriate M.T.O. and electrical design codes. All work shall be performed in accordance with the current edition of the Ontario Electrical Code, including all appending bulletins issued by the Electrical Safety Authority which are applicable to the work. All work shall be governed by Federal, Provincial and Local laws and by-laws pertaining to the work, as well as by the latest issue of CSA Standards pertinent to the work. All electrical work is subject to inspection by the Electrical Safety Authority. In the event of a conflict between regulations, the strictest regulation shall apply.

In addition to accommodation of traffic flow, the signalized intersection design shall include pedestrian requirements and accessibility features. All signalized crossings must be designed in accordance with the TAC "Guidelines for the Understanding, Use, and Implementation of Accessible Pedestrian Signals".

11.3.1 Installation

The installation shall include the following features:

- a) Traffic signal controllers must be pad mounted and in a location that is not visually distracting;
- b) A separate power pedestal is to be provided;
- c) The power supply is to be metered;
- d) The traffic signals shall include emergency vehicle pre-emption;
- e) Twin 100 mm ducts are to be provided across the roadway approaches to the 600 mm diameter electrical handwells;
- f) Twin 100 mm ducts are to be provided from the controller cabinet to the first handwell;
- g) The controller cabinet shall be raised 450 mm above grade with a cabinet base extension;
- h) Loop detectors shall be placed in the base asphalt; and
- i) The controller shall conform to the NEMA standard TS2 Type 2 Standard capable of handling eight (8) phases, solid state, micro-processor-based traffic signal controller with LCD display.

11.3.2 Testing

Tests on electrical wiring and materials shall, unless otherwise specified, conform to the Canadian Electrical Code Part 1, and shall include insulation value readings and resistance to ground readings.

The following tests will be required:

- a) All conduits and duct systems shall be proven free of stones, dirt, water or other debris by pulling a test mandrel 1/4 inch (6.4 mm) smaller in diameter than the nominal conduit or duct size and 12 inches (300 mm) in length through each individual conduit or duct;
- b) All circuits shall be proven continuous and free of short circuits or ground faults;
- c) All circuits shall be proven free of unspecified grounds and the resistance to ground of all circuits shall be no less than fifty (50) megohms; and
- d) The resistance to ground for all grounded equipment shall be proven to not exceed twenty-five (25) ohms.

11.3.3 Pavement Markings and Traffic Signs

Marking materials for stop bars, pedestrian crosswalks, direction arrows, and lane markings are to be durable hot applied thermoplastic pavement marking material, as per OPSS 1713.

All related traffic signal signing shall be as per the Ontario Traffic Manual Books 5, 6 & 7 including but not limited to:

- a) Advanced WB-102 “Traffic Signal Ahead” sign with WB-3 “New” sunburst sign on wood posts;
- b) WA-33L “Object” markers affixed to a median traffic pole; and
- c) A RB-125 “Keep Right” on wood posts located at the end of the median island. The signs shall be made upon 0.081 aluminum blanks with hi-intensity reflective sheeting.

12 Landscaping

12.1 TREE PRESERVATION

This section provides policies, general standards and guidelines for the protection of existing trees during construction and for the planting of new trees. The section outlines tree inventory, preservation and protection requirements to ensure existing vegetation is retained where required, and measures to ensure damage to existing vegetation is minimized.

12.2 TREE INVENTORY REQUIREMENTS

The Tree Inventory drawing should be utilizing the most current available boundary survey as a base layer reference. For the entire property to be developed, the Proponent shall submit a Tree Inventory drawing for all trees greater than 100 mm diameter-at breast-height (dbh) on the subject property as well as for any trees on adjacent property whose canopies extend onto the property to be developed. For forests or other continually treed areas that are to be protected, the detailed inventory shall extend into the forest 15 m from the edge while the remainder of the forest shall be described on the basis of species present and range of sizes (dbh) for each species. For forests or other continually treed areas that are to be removed in their entirety, a general inventory shall be provided as described above. At the discretion of Town Staff, a sampling procedure may be used to prepare the inventory for well-treed lots. A sampling procedure may be used to estimate the tree inventory within a woodlot setting, with a minimum area of 200m² or 5% of the total lot area, whichever is greater. In all instances, any rare or endangered tree species of any size shall be identified and accurately located on the plans. The Town may require, at its discretion that significant trees must be individually inventoried and assessed, even when they occur within large stands. It is advised that Town Staff be contacted regarding the required scope for tree inventory requirements.

Inventoried trees shall be numbered, and these numbers must correspond to the arborist report and the Tree Protection Plan as outlined below.

12.3 TREE PROTECTION & REPORT

An arborist report shall be prepared by an ISA Certified Arborist or Registered Professional Forester which details specific and accurate information about trees that may be impacted by the development initiative and identifies the nature of the work to be undertaken, and appropriate protection measures. For all trees that must be individually inventoried, as described above, the report is to include:

- Tree number;

- Species (Scientific and Common Name);
- Diameter at Breast Height;
- Canopy Diameter;
- Assessment of Condition, including health, vigour, and structural integrity;
- Suitability for Retention; and
- Minimum Tree Protection Zone (TPZ) (radius in metres).

Additionally, the report should confirm the presence and location of any rare or endangered species and provide recommendations for protection. The arborist assessment should also inventory and assess any areas requiring a general inventory, as described above, and provide an assessment of the impacts of the proposed works and recommendations for retention or preservation. The report should include recommendations for tree protection measures and all aspects of tree health including tree pruning, fertilization, mulching, irrigation and long-term monitoring and maintenance. Trees identified for removal for health or hazard reasons should first establish that the problem cannot be corrected by pruning or other treatments.

A Tree Protection Plan shall interpret the recommendations of the arborist report, designating trees to be removed, preserved, and compensated on the subject and adjacent property. It shall provide clear direction to the Contractor. The Tree Protection Plan and Tree Inventory may be combined, depending on the complexity of the project and at the discretion of the Town.

12.4 TREE PRESERVATION MEASURES

Lot grading should demonstrate best efforts to minimize perimeter disturbance and preserve existing trees. Through the site layout design the developer should attempt to incorporate design alternatives, such as adjustments to grade, which minimize the impact to vegetation.

Grading Plans are the preferred base layer reference for Tree Preservation and Tree Compensation drawings.

Tree protection fencing shall be erected at the minimum of 0.3m outside of the dripline prior to commencement of any clearing, grading or other construction activity. All supports and bracing used to secure the barrier should be located outside the Tree Protection Zone to minimize damage to roots.

In instances where a specimen tree is to be retained in proximity to a construction area, wood hoarding will be required.

Tree protection shall not be removed until completion of all construction activity.

Where protection barrier is on slopes greater than 4%, provide a ditch on the elevated side of the fence, lined with filter fabric and backfill to prevent erosion.

12.5 TRENCHING AND TUNNELING

No trenching is to occur within Tree Protection Zones. Excavations under the dripline of a tree should be executed with a trencher, vacuum truck, or other method approved by the Town.

Roots encountered during trenching operations that are greater than 50 mm are to be pruned by a certified arborist.

Directional boring or micro-tunneling are permitted within a Tree Protection Zone provided that they are in accordance with the arborist report and meet the following standards:

- They occur at a minimum depth of 1.0 m;
- The bore or tunnel is a minimum of 1.0 m horizontally from the outside edge of the trunk of the tree; and
- The open excavation occurs outside the Tree Protection Zone.

All other Tree Protection Zone requirements (e.g. no storage of equipment or materials, no operation of equipment, etc.) shall continue to apply.

12.6 TREE COMPENSATION REQUIREMENTS

Tree compensation calculation methods will be at the discretion of the Town on a case-by-case basis.

Town Staff will consider a combination of factors including but not limited to canopy area, lot size, tree density, cultural importance, and/or land designation. It is advised that Town Staff be contacted regarding the required tree compensation rate requirements.

The standard compensation rate for trees removed from a landscape setting are calculated using the chart below. The replacement value of a tree is determined by its caliper at breast height, corresponding replacement caliper range, and compensation rate. Trees that have been removed prior to being inventoried will be compensated at the discretion of the Town, to ensure the principle of 'no net loss of trees' is followed.

Table 25: Tree Compensation Ratios

| REMOVE TREE DBH | COMPENATION RATIO |
|-----------------|-------------------|
| 100mm - 150mm | 1 to 1 |
| 151mm - 350mm | 2 to 1 |
| 351mm - 500mm | 3 to 1 |
| >501mm | 4 to 1 |

All replacement trees should be provided at nursery stock standards unless smaller stock is deemed appropriate.

A tree health coefficient is applied to each tree prior to calculation of total compensation. The coefficient is multiplied to the replacement rate for that tree to determine a compensation rate relative to a healthy specimen. The total replacement rate is accumulated and rounded to the next whole number.

Table 26: Tree Health Coefficient

| HEALTH OF TREE | HEALTH COEFFICIENT |
|--------------------|--------------------|
| Dead | 0 |
| Hazard or Infected | 0.25 |
| Poor | 0.5 |
| Fair | 0.75 |
| Good | 1 |

If the minimum number of replacement trees cannot reasonably be met, as determined by Town Staff, tree compensation shall be in the form of shrubs at a compensation ratio of 5 shrubs to 1 tree.

If compensation cannot be provided, a cash in lieu agreement may be entered by the Developer. The rate for cash in lieu will be \$500 per replacement tree not planted on the site.

12.7 LANDSCAPE REQUIREMENTS

All landscape plans shall be prepared by an accredited professional Landscape Architect in good standing with the Ontario Association of Landscape Architects (OALA). The Landscape Architect shall coordinate and liaise with all other consulting professionals to ensure accurate representation of the site and the proposed development.

This section provides guidelines, policies of procedure and practice that are to be adopted by the proponent. Specific guidelines are included for plant materials, including nursery grown trees, topsoil, shrubs, groundcovers, sod and seed mixtures.

12.8 TOPSOIL & SEED REQUIREMENTS

Topsoil shall conform to OPSS 802. Additional to the specifications, the subgrade is to be loosened to a depth of 100 mm immediately prior to topsoil application and the topsoil is to be placed no longer than seven (7) days prior to seeding or sodding. Topsoil depth requirements (after settlement or compaction to 85% SPD) are as follows:

Table 27: Topsoil Requirements

| VEGETATION | TOIPSOIL DEPTH REQUIREMENTS |
|-------------------------------------|---------------------------------|
| Boulevards | 300 mm minimum continuous depth |
| Shrub Planting Beds | 500 mm minimum continuous depth |
| Tree Planting Pits/Beds | 500 mm minimum continuous depth |
| Sodded/Seeded Areas (non-boulevard) | 200 mm minimum continuous depth |

Topsoil stockpiles containing more than 100 m³ of material shall be located a minimum of 10.0 m away from any roadway, drainage channel or an occupied residential lot. Topsoil shall not be stockpiled on slopes steeper than 2H:1V and the stockpile height shall not exceed 6.0 m. Runoff from all topsoil stockpiles shall be controlled by a sediment control fence or other approved devices.

Temporary seeding of topsoil with cover crops may be required by the Town to prevent weed growth.

Screen stockpiled topsoil, as necessary. Use a screener having a wire mesh screen size opening of minimum 10 mm and maximum 19 mm to remove stones, soil lumps, foreign material, debris, undesirable plants and roots. Stockpile topsoil shall be reasonably free of weed growth before placement on site.

Temporary topsoil stockpiles are not to be located in open space or park areas.

Refer to **Appendix B** for approved seed mix designs.

12.9 PLANT MATERIAL CONSIDERATIONS

All plant material shall be nursery grown and conform to the Canadian Standards for Nursery Stock (latest edition).

The minimum size requirements for plant material are as follows:

- Deciduous trees: 50 mm caliper, Wire Basket.
- Coniferous trees: 200 cm tall, Wire Basket.
- Deciduous shrubs: 50 cm tall, 3 gallon pot.
- Coniferous shrubs: 50 cm wide, 3 gallon pot.
- Perennials and Ornamental Grasses: 1 gallon pot.

Whips (bare-root stocks measuring 1.0 m to 1.5 m in height) may be planted in low-profile, rural areas, and stormwater management facilities, provided that they meet the requirements of the applicable Conservation Authority Guidelines. Seedlings or whips may be used for naturalization or restoration areas.

All trees shall be true to type, structurally sound with no evidence of dead branches, sun scald, frost cracks, abraded or broken bark, and be free of insect or disease infestation.

All trees shall have a full, well-developed symmetrical crown with one distinctive vertical leader, branches appropriately spaced, and a root system typical of the species. All parts shall be moist and show active green cambium when cut.

All trees must meet these specifications at the time of planting and final inspection by the Town's designate. Trees that are rejected will be replaced at the Proponent's expense.

All tree and shrub plantings shall be in accordance with the Town Standard Planting Details.

The crown of the tree shall be pruned from the bottom up at the time of planting to remove all dead and damaged branches and to address any structural weaknesses, such as codominant branches, multiple branches arising from one point, included bark, etc. All pruning is to conform to ANSI A300 Pruning Standards. After pruning, the tree should have a symmetrical and full crown. Trees that do not meet these requirements will be rejected.

Tree stakes shall be heavy duty gauge T-bars, 50 mm x 50 mm x 1800 mm long. Ties shall be 50 mm burlap strips or a proprietary flexible tie system which allow the tree a reasonable degree of movement to help build trunk taper. Plastic hoses and wire ties are not acceptable. Ties are to be removed after one year.

Mulch shall be shredded cedar bark, free of dyes and chemicals that inhibit plant growth.

Rodent guards shall be used on deciduous trees for all naturalization plantings, including storm water pond plantings. Rodent guards shall consist of white plastic spiral wrap wound around the base of trunk, up to a height of 60 cm or for seedlings, shall consist of 1200 mm long polypropylene tree shelters, twisted 50 mm into the ground. These guards must be installed after planting and inspection and then removed after two (2) years of growth (for spiral guard) or when seedlings grow taller than the tree shelter.

12.10 ACCEPTANCE AND WARRANTY

All plant materials shall be maintained by the Proponent, from the time of planting until acceptance by the Town.

A maintenance regime shall consist of proper cultivation, weeding, watering and pruning to establish and maintain plant material in a healthy growing condition.

The Proponent shall arrange a time to have the plant material accepted following the guarantee period. At the time of inspection, all beds and tree pits shall be freshly cultivated, weeded and in a tidy condition, with all rubbish, leaves and dead plant debris removed.

12.11 DESIGN CONSIDERATIONS

In this section the requirements relative to acceptable tree species and related landscaping components with respect to specific applications are provided.

12.12 ACCEPTABLE TREES

Refer to **Appendix C** for a list of Acceptable Trees. Varieties and cultivars of the species listed will be reviewed pending specific site conditions and design applications.

In selecting trees for specific applications, consider the following factors:

- Assess conflicts with power lines, sidewalks and underground utilities;
- Select large trees where space is available to maximize planting effect;
- Encourage diversity of species to reduce susceptibility to disease;
- Utilize native species as much as possible;
- Consider long-term maintenance pruning requirements of trees;
- Select species with respect to soil microclimate requirements; and
- Select species with respect to salt tolerance and specific moisture requirements.

12.13 MIXTURE AND PROPORTION OF SPECIES

The planting of monocultures (dependence on one plant species) within the streetscape is detrimental to the maintenance of tree health, and increases a tree's overall susceptibility to pests and diseases. As such, the Town encourages biodiversity in the streetscape, stormwater management, and restoration plantings by implementing the following measures:

- The random sequencing of tree species is encouraged within a planting scheme.
- The planting of any one individual species is limited to eight (8) consecutive trees in any given planting scheme, including both sides of a road allowance.
- To ensure diversity, the amount of one tree genus shall not exceed more than 20% of all plantings, and the amount of one tree species shall not exceed more than 10% of all plantings.
- The number of species required in a planting scheme shall be determined by the overall number of trees in the planting, as conforming to the following table.

Table 28: Number of Trees and Species in Planting

| NUMBER OF TREES IN PLANTING | MINIMUM NUMBER OS SPECIES |
|-----------------------------|---------------------------|
| 1-8 | 1 |
| 9-15 | 2 |
| 16-30 | 3 |
| 31-40 | 4 |
| 41-50 | 5 |
| 51-100 | 6 |
| 101+ | 8 |

12.14 TREE SITING AND SETBACK REQUIREMENTS

Boulevard tree siting requirements are as follows:

- Boulevard trees are to be large crown trees, optimally planted at intervals ranging from 12.0 m to 15.0 m.
- In single family detached residential developments as well as multi-unit developments, one (1) shade tree per lot is required. Where a tree cannot be accommodated on a lot, the tree may be planted on other public land within the development property, as directed by the

Town. Should the tree not be accommodated on the development property, the Town will accept five-hundred dollars (\$500) cash in lieu for each tree not planted.

- Where overhead utilities or other constraints require the use of smaller trees, they may be used at the discretion of the Town, at a spacing of 6.0 m to 8.0 m on center.

When planting near utilities, the location and species of the plant material must be coordinated with engineering plans to ensure the non-obstruction of storm and sanitary sewers, water service, hydro, telephone, gas lines and other services. All utilities must be demarcated by the Proponent prior to any excavation.

12.15 LANDSCAPE STRIP REQUIREMENTS - RESIDENTIAL DEVELOPMENT

The following landscape treatments are guidelines for the location and use of plant material, fencing, berming on private lands adjacent the public road Right-of-Way. The planting density formulae establishes the desirable quantity of each type of plant material based on the proposed land use and the total site area. The following table outlines the landscape strip standards utilized by the Town for residential development adjacent to various road classifications and abutting land uses.

Table 29: Landscape Strip Requirements

| ABUTTING USE | MINIMUM LANDSCAPE STRIP WIDTH | LANDSCAPE TREATMENT GUIDELINES |
|---------------------|-------------------------------|--|
| Arterial/Parkway | 6 m | <ul style="list-style-type: none"> ▪ Entry feature/ornamental fencing ▪ Mixed Deciduous and Evergreen trees ▪ Berming and shrub beds ▪ Foundation planting |
| Collector/Local | 3 m | <ul style="list-style-type: none"> ▪ Entry feature/ornamental fencing ▪ Mixed Deciduous and Evergreen trees ▪ Berming and shrub beds ▪ Foundation planting |
| Schools | 3 m | <ul style="list-style-type: none"> ▪ 1.8 m high chain link fence ▪ Mixed Deciduous and Evergreen trees ▪ Mixed shrub bed or hedging |
| Other Institutional | 3 m | <ul style="list-style-type: none"> ▪ Mixed Deciduous and Evergreen trees ▪ Mixed shrub bed or hedging ▪ 1.8 m high solid fence (with 150 mm x 150 mm posts) |
| Residential | 3 m | <ul style="list-style-type: none"> ▪ Mixed Deciduous and Evergreen trees ▪ Mixed shrub bed or hedging |

| ABUTTING USE | MINIMUM LANDSCAPE STRIP WIDTH | LANDSCAPE TREATMENT GUIDELINES |
|-----------------|-------------------------------|--|
| Commercial | 3 m | <ul style="list-style-type: none"> ▪ 1.8 m high solid fence (with 150 mm x 150 mm posts) ▪ Mixed Deciduous and Evergreen trees ▪ Mixed shrub bed or hedging |
| Industrial | 3 m | <ul style="list-style-type: none"> ▪ 1.8 m high solid fence (with 150 mm x 150 mm posts) ▪ Mixed Deciduous and Evergreen trees ▪ Mixed shrub bed or hedging |
| Open Space/E.P. | 3 m | <ul style="list-style-type: none"> ▪ 1.2 m high chain link fence ▪ Mixed Deciduous and Evergreen trees ▪ Mixed shrub bed or hedging |

Planting Density Formula Guideline:

- Total Site Area (m²) ÷ 200 = # of Deciduous Trees 50 mm caliper.
- Total Site Area (m²) ÷ 400 = # of Evergreen Trees 2.0 m in height.
- Total Site Area (m²) ÷ 50 = # of Deciduous Shrubs 0.6 m - 1.2 m in height.
- Total Site Area (m²) ÷ 100 = # of Evergreen Shrubs 0.45 m SPR/1.2 m in height.

12.16 PARK AND PLAYGROUND REQUIREMENTS

12.16.1 Minimum Park Requirements for Residential Developments

Components of Parkland and other Open Space considerations are as follows:

- Park display sign to be 1.8 m wide by 1.2 m high installed on two 0.75m aluminum or hot-dip galvanized steel poles. Park display sign to be as per the "RT07 Wayfinding Signage Standards and Specifications" page 7-1.1 (Drawing - Pd-1a Urban Pedestrian RTO 7 Map Directory). The sign text and image information will be provided by the Town for each park display sign.
- Park servicing: minimum 25 mm water service, 125 mm sanitary sewer service, 250 mm storm sewer service, and a hydro service are minimum requirements. The Town will provide minimum sizes specific to the project in early stage of designs.
- Park grading: minimum slopes of 2% graded to maintain proper drainage. Using slopes steeper than 4% is undesired.
- Park fencing: 1.8m high chain link fence.

- Must have street frontage.
- Park turf: sodding is the minimum standard.
- Development construction: undeveloped, disturbed blocks shall be graded, seeded, and maintained by the Proponent until construction commences thereon.
- Park property shall not be used for storage of material or equipment during construction on development.

12.16.2 Development Adjacent to Park Property

Where development abuts a Park or Open Space, runoff from the development property shall not drain into the Park or Open Space. A rear lot catch basin may be required.

12.16.3 Park and Open Space Features

Required park and open space features include:

- Chain link fence (1.8 m) to Town standards where Park property is adjacent to private lots. No gates into parks, open spaces, or stormwater management facilities are permitted from private property. Park frontage on streets is not fenced.
- Site furniture, including benches and trash cans.
- Park walkways that are to be maintained in the winter must be 3 m width, asphalt surfaced. Otherwise, park walkway material is stone dust.
- Lighting of Park walkways in Neighbourhood Parks is generally not recommended.
- Lighting of sports facilities in Neighbourhood Parks is generally not recommended.
- Playgrounds must conform to the latest Canadian Standards Association (CSA) standards for play spaces and equipment.
- At least one (1) light standard must be provided at playgrounds for security.

12.16.4 Parking Supply Standards

Parking lots may be required for Neighbourhood Parks, if there is no adjacent parking.

Parking Supply Standards for Community or Town-wide parks:

- Sixteen (16) spaces per ball field, thirty-two (32) spaces if fields are lit.
- Sixteen (16) spaces per soccer field, thirty-two (32) spaces if fields are lit.
- Fifteen (15) spaces for general park users.
- Twelve (12) spaces (four (4) per court) per group of tennis courts.

12.16.5 Park Development Standards

All Parks and Open Space developed in the Town shall comply with the following standards:

- Can/CSA Standard Z614 – Children’s Playspaces and Equipment (latest edition).
- Accessibility for Ontarians with Disabilities Act (AODA), 2005, including all associated Regulations.

12.16.6 Playground Equipment Standards

The playground will be separated into distinct play area sections: a Junior play area for children eighteen (18) months to five (5) years old and a Senior play area for children five (5) years to twelve (12) years old.

It is acceptable to mix products from different manufacturers on a project site.

Specify steel posts, not aluminum for lower costs. Timber and wood components are not acceptable.

All playgrounds must have a minimum 1.5 m wide, hard surface pathway from the street or sidewalk to the play area for accessibility.

All playground equipment must be installed by a certified playground installer and must meet CSA standards.

12.16.7 Typical Playground Requirements

A typical program for a Neighbourhood Park must include at a minimum:

- Swings – two (2) seats for toddlers, four (4) belt seats, and one (1) accessible seat.
- Jr. creative structure: two to three (2-3) decks with minimum one (1) roof, transfer station & stairs, two (2) plastic slides – single and dual track, climber, tunnel or bridge between decks, three to four (3 - 4) activity panels, and talk tube or alternate.
- Sr. creative structure: three to six (3-6) decks with minimum one (1) roof, transfer station with stairs, accessibility ramp, two (2) plastic slides – straight and spiral both open, three (3) climbers, rock wall or similar activity, four to five (4-5) activity panels, and sliding pole.
- Spring/spinning toys: two (2) units varying types.
- A typical program for a Community Park must include at a minimum:
- Swings – five (5) seats for toddlers, six (6) belt seats, and one (1) accessible seat.

- Jr. creative structure: two to three (2-3) decks with minimum one (1) roof, transfer station & stairs, two (2) plastic slides – single and dual track, climber, tunnel or bridge between decks, three to four (3-4) activity panels, and talk tube or alternate.
- Sr. creative structure: five to seven (5-7) decks with minimum one (1) roof, transfer station with stairs, accessibility ramp, two to three (2-3) plastic slides – straight and spiral both open, three to four (3-4) climbers, rock wall or similar activity, five to seven (5-7) activity panels, and sliding pole.
- Spring/spinning toys: three to four (3-4) units varying types.

12.16.8 Creative Play Structures

Only certified playground suppliers are permitted to supply and install play structures. Playground structures are subject to inspection by a registered playground inspector.

Decks:

- Steel with plastisol coating preferred or plastic wood is acceptable.
- Provide a transfer deck on structure to make it accessible.
- Provide minimum one (1) set of stairs.
- Climbers.
- Chain net, cable net, and cargo net climbers shall have one piece coupling or nut and bolt couplings. Screw couplings are not acceptable.

Activity Panels:

- Do not place a poly panel at the end of a ramp.
- Use steel bars at ends of ramps.
- Vary steel bars, poly windows, activity panels to add interest to structure.
- Provide 40% of activity panels on ground level for wheelchair users.

Percussion musical panels are not permitted, except in low vandalized areas. All other activity panels will be considered but must be approved by the Town.

12.16.9 Play Areas

Perimeter

Playground play area borders are to be cast-in-place concrete curbs or concrete sidewalks.

Ensure minimum setbacks are provided from each piece of play equipment as per CSA standards.

Drainage

Provide a subdrain system comprised of a minimum 100 mm (4") diameter corrugated poly drain pipe with filter sock embedded in a French drain of 300 mm wide x 400 mm deep 19 mm diameter clear stone set into the subgrade.

Slope subgrade to drain towards drain pipe at 1.0%.

Provide a non-woven geotextile filter fabric between the safety surface and French drain.

Provide a minimum three (3) legs of drain pipe to cover all sides and centre of play area.

Slope drain pipe a minimum 0.5% to drain towards a catch basin or discharge into a swale.

Ensure placement of drainage pipe does not interfere with play equipment footings.

In poorly drained areas: In addition to above, provide a drainage layer immediately beneath the safety surfacing comprised of 100 - 150 mm (4" - 6") 19mm diameter clear drain stone with a non-woven geotextile filter fabric.

12.16.10 Play Equipment

Spring Toys

Spring Toys must be removable by Parks Maintenance personnel.

Swing Standards

All swing posts shall be embedded in footings (anchor footing to bedrock where depth of cover is not at least 1200 mm).

Top cross bar shall be min. 2440 mm (8'-0") above finished grade.

All swing chains shall be ¼" galvanized steel.

Slide Standards

Must be attached to creative play structures.

Poly slides are to be used except in highly vandalized areas, where stainless steel slides may be used.

12.17 FENCING

Commercial grade, galvanized steel, chain link fence or our black vinyl coated chain-link shall be the preferred option within residential developments, however, this should be confirmed by the Town.

Park, soccer and ballfield perimeter - #9 gauge (3.5 mm).

Baseball field backstops - 50 mm (2") square mesh, #6 gauge (5 mm).

Basketball/multi-purpose court - 3.0 m (10 ft.) high.

13 Drawing Requirements

13.1 SPECIFICATIONS FOR ENGINEERING DRAWINGS:

All plans are to be A1 size and shall bear the seal of the registered Professional Engineer responsible for the design.

All preliminary submissions shall be hard copy bonded.

All final submission and "as-constructed" drawings shall be bonded hard copies and with digital CAD files.

13.2 GENERAL DRAWING REQUIREMENTS

All engineering drawings shall be prepared in metric and in a neat and legible fashion. The design information presented on these drawings shall be completed in ink.

All plans shall have a title block and a revisions block. All revisions to the plans shall be properly noted in the revisions block with the revision number and date revised.

The lot numbering and block identification on all engineering drawings shall be the same as shown on the Registered Plan for the area.

All elevations shown on the engineering drawings are to be of geodetic origin. A local benchmark note must appear in each drawing.

All plan and profile drawings are to be prepared so that each street can be filed separately. The street names shall be identified on the plan portion of the drawings.

When streets are of a length that requires more than one drawing, match lines are to be used with no overlapping of information.

The reference drawing numbers for all intersecting streets and match lines shall be shown on all plan and profile drawings.

A north arrow and key plan shall be included on all drawings.

All engineering drawings shall be stamped by a Professional Engineer. The Engineers stamp must be signed and dated.

Work on the drawings to be done neatly and legibly.

Existing information shall be shown light or background line weight. Proposed information shall be shown bold or foreground line weight.

In general, east-west streets shall have zero chainage at their westerly limit and north-south streets shall have their zero chainage at their southerly limits. Chainage on a plan-profile shall increase from left to right.

13.3 COMPUTER AIDED DRAWINGS (CAD)

Digital software compatible with AutoCAD shall be used to prepare all drawings.

13.4 GENERAL SERVICING PLANS

A “General Plan of Services” drawing showing aboveground services and appurtenances shall be prepared for all developments at a maximum scale of 1:1000.

The reference Geodetic Benchmark and the Site Benchmarks to be used for construction shall be identified on the General Plan of Services.

A Key Plan shall be shown on all “General Plan of Services” drawings and the area covered by the drawing shall be clearly identified.

A drawing index shall be shown on all “General Plans of Services” to identify the Plan and Profile Drawing number for each street or easement shown.

All road allowances, lots, blocks, easements and reserves are to be shown and are to be identified in the same manner as shown on the Registered Plan.

All existing services, utilities and abutting properties are to be shown.

All services to be constructed are to be shown.

All sites for parks, schools, churches, commercial and industrial development must be shown.

If a subdivision encroaches on an existing floodplain, the approved fill line restrictions must be shown, as specified by the MNR and/or CVCA, GRCA.

General Plans shall indicate, but not be limited to the following:

- Roadways with curblines and street names;
- Water mains and appurtenances, with notes showing sizes;
- Maintenance holes with numbers;
- Sewers with notes showing sizes, and direction of flow;
- Signage;
 - School;
 - traffic control;

- future land use;
- Barricades;
- Fencing indicating height and type;
- Retaining walls;
- Catchbasins;
- Community mail boxes with number of units serviced;
- Hydro vaults, streetlights, sidewalks.

13.5 STORM DRAINAGE PLANS

The plan shall be prepared to a scale of 1:1,000 or 1:2,000.

The storm drainage plan shall indicate but not be limited to the following:

- Existing contours at maximum 1.0 m intervals;
- Drainage patterns of adjacent lands;
- Run-off coefficients and areas (ha) of tributary areas outside the development and for each section of the storm sewers within the development;
- Direction of run-off;
- Street names;
- Maintenance hole numbers;
- Sewer sizes, slope and directions of flow;
- Any catchbasins or swales, on the lots or blocks, required to collect the run-off;
- Temporary or permanent quantity and quality storm water management facilities;
- Major and minor overland flow routes; and
- Culverts and other drainage appurtenances.

13.6 SANITARY DRAINAGE PLANS

All tributary areas used for the determination of the design flows shall be shown on a plan at the scale of 1:1,000. The plan shall indicate the land use, area and population density or number of units. Each sanitary drainage area on the plan shall show an identification number along with population and area.

13.7 GRADING PLANS

Grading plans shall be a minimum scale of 1:500.

The grading plans shall indicate, but not be limited to the following:

- All lots and blocks within the subdivision, numbered in accordance with the plan proposed for registration;
- Existing contours at maximum 0.5m intervals within the subdivision and extended outside the subject lands far enough to determine the existing drainage pattern;
- Driveway, water service box locations and building envelopes;
- Elevations at existing trees, structures, watercourses, etc.;
- Centerline elevations of proposed and existing roads at maximum 15m intervals;
- Proposed elevations at front and rear building envelope;
- Proposed elevations at the corners of each lot and block and intermediate point of grade change;
- Proposed elevations at sideyard highpoints if applicable;
- Proposed 0.5m contours for grading within large blocks and parks;
- Proposed grades for major and minor overland flow routes;
- Lot fabric of subject lands including lot, block and easement description;
- Physical structures such as fencing, retaining walls, etc.;
- An arrow indicating the direction of the surface water run-off from all lots;
- All swales, other than the normal side yard swales, along with percent grade and the invert elevation of the swale at regular intervals;
- All rear yard catchbasins including the rim elevation of the catchbasin and the invert elevation of the outlet pipe;
- All terracing required with the intermediate grades specified;
- The lot grading plan shall make note of the typical grading details for various lot drainage types provided on separate detail drawings;
- Proposed locations for building envelopes and envelopes for private sewage disposal systems;
- All proposed easements for registration;

- Heights of proposed retaining walls, fences etc.

13.8 PLAN-PROFILE DRAWINGS

Plan - Profile drawings are required for all roads, service easements, drainage channels and outlets.

Plan-profile drawings are to be drawn to a minimum horizontal scale of 1:500 and a vertical scale of 1:50 and are to include the following:

- Complete legend.
- All existing or future services, utilities and abutting properties.
- All services to be constructed.
- The profile portion of the drawing shall be a vertical projection of the plan portion whenever possible.
- All road allowances, lots, blocks, easements and reserves are to be shown and are to be identified in the same manner as on the Registered Plan.
- All curb and gutter and sidewalks shall be shown and dimensioned on the plan portion of the drawing.
- Where multiple drawings are required for one street, match lines must be used with no overlap or duplication of information.
- Where intersecting streets or easements are shown on a plan-profile, only the diameter of the pipe and direction of flow of the intersecting sewers shall be shown.
- On profile portion of drawings the type of sewer, diameter, length and grade shall be shown.
- On profile portion of drawings the water main diameter and length, shall be shown.
- Only the direction of flow and diameter of pipe shall be shown in the plan portion.
- All maintenance holes shall be shown on the plan and on the profile portions of the drawing and be identified by chainage and I.D. number and shall also be referred to the applicable Standard Drawing or to a special detail on the profile portion of the drawing. All invert elevations shall be shown on the profile with each having reference to the north arrow.
- All sewer maintenance holes which have safety platforms are to be noted.
- All drop connections are to be noted and referred to the Standard Drawing.
- All catchbasins and catchbasin connections shall be shown. Catchbasins are to be numbered for easy reference. All rim and invert elevations for rear lot catchbasins are to be shown.

- All water mains, hydrants, valves, etc. shall be shown, described and dimensioned on the plan portion of the drawing. In addition, the water main shall be draw to true scale size on the profile portion of the drawing and shall be described.
- The location of all storm, water and sanitary service connections shall be shown on the plan portion of the drawing using different symbols for each service.
- The centreline of construction with the 20 metre stations noted by a small cross shall be shown on the plan portion of the drawing.
- The original ground at centreline and the proposed centreline road profile shall be plotted on the profile. The proposed centreline road profile shall be fully described (length, grade, P.I. elevations, vertical curve data, high point chainages, low point chainages, etc.).
- Details of the gutter grades around all 90 degree crescents, intersections and culs-de-sac shall be provided on the plan portion of the drawing as a separate detail at a scale of 1:200.
- Chainage for the centreline of construction are to be shown on the profile portion of the drawing. The P.I., B.H.C., E.H.C., B.V.C. and E.V.C. chainages are to be noted.
- All existing services, utilities and features are to be shown on the plan portion. Those services and utilities below grade that are critical to the new construction shall also be shown in the profile.
- Profiles of roadways shall be produced sufficiently beyond the limits of the proposed roads, to confirm the feasibility of possible future extensions.
- The location of all luminaire poles shall be clearly shown on the plan portion.
- The proposed location and type of all street name and traffic control signs shall be shown on the plan portion.

13.9 COMPOSITE UTILITY PLAN

Composite Utility Plan shall be prepared in the same format as “General Plan of Services” and showing the location of hydrants, trees, entrances, poles, street lights, transformers, water shut-offs, etc.

13.10 DETAIL DRAWINGS

The Town of Erin Standard Drawings and the latest revision of the Ontario Provincial Standard Drawings (OPSD) shall be utilized whenever applicable. These drawings shall be reproduced as part of the engineering drawings for the development and must be referred to by number on the affected drawings. Individual details shall be provided for all special features not covered by the Town of Erin Standard Drawings or OPSD.

13.11 PARKLAND DEVELOPMENT DRAWINGS

The Developer shall be responsible to prepare a detailed Grading Master Plan for approval by the Town, for all lands to be dedicated for park purposes. This plan shall show all existing trees and features that are in conformity with the end use of the park and that are to remain. All other trees shall be removed by the Developer subject to approval. Prior to preparing park development plans, the Developer shall meet with Town staff to review Town recreational needs, i.e. soccer pitches, ball diamonds, etc.

This Master Plan shall be prepared at a scale of 1:500 and form part of the approved Engineering Drawings, indicating the following, at a minimum:

- Existing contours at a maximum of 0.5 m intervals;
- Drainage structures and direction of overland drainage;
- Species and size of existing plant material to remain and be protected;
- Species and size of plant material to be removed;
- Proposed underground services, as required;
- Layout of all proposed recreation facilities;
- Layout of parking lot and spaces (including handicapped parking);
- Layout of all trails;
- Proposed site amenities including benches, bike racks, trash receptacles, signs, washrooms;
- Perimeter fencing;
- Park lighting;
- All surface treatments; and
- All proposed plant materials.

13.11.1 Trails and Walkways

Drawing requirements for trails and walkways will be determined in conjunction with the Town at the time the need is identified.

13.12 LANDSCAPING

All landscape plans shall be drawn and stamped by a Full Member of the Ontario Association of Landscape Architects. All landscape plans shall be drawn at a minimum scale of 1:500.

The landscape drawings may include the following:

- Tree Preservation Plan and Details;
- Streetscape and Buffer Planting Plans and Details;
- Detailed Park Development Plans and Details;
- Trails Master Plans and Details;
- Landscape Restoration Plans and Details;
- Stormwater Management Facility Planting Plan;
- The Streetscape Plan shall show the following:
 - existing trees and natural features to remain;
 - building envelopes, driveways and sidewalks;
 - walkways, trails and easements;
 - required fencing including privacy, acoustic and chain link;
 - proposed plantings;
 - entry features;
 - location of street lighting;
 - location of public utility boxes and easements and hydrants; and
 - heights of existing and proposed retaining walls, fences etc.

Construction details will be required for all landscape elements to be implemented as part of the development.

13.13 AS-CONSTRUCTED DRAWINGS

The “As-Constructed” drawings constitute the original engineering drawings that have been amended to incorporate the construction changes and variances in order to provide accurate information on the works as installed in the field.

13.13.1 “As-Constructed” Field Survey

The “As-Constructed” revisions shall be based upon field survey of all the services installed. The field survey shall include the following items:

- a) Location and invert elevations of all sewer maintenance holes.
- b) Distances between all sewer maintenance holes.
- c) Location of all roadway catchbasins.

- d) Location, rim and invert elevations for all rear yard and lot catchbasins.
- e) Location of all sidewalks and curbs.
- f) Location and ties to all valve boxes and valve chambers.
- g) Location of all hydrants.
- h) Location and ties to all special water main appurtenances.
- i) Road centreline elevations.
- j) Site benchmarks.
- k) Location of all service connections to all lots and blocks and location of connection from nearest downstream maintenance hole.
- l) Sewer pipe sizes.
- m) Location of all fencing constructed.

13.13.2 Drawing Revisions

The original drawings shall be revised to incorporate all changes and variances found during the field survey and to provide the ties and additional information to readily locate all underground services.

All sewer and road grades are to be recalculated to two decimal places.

All Street line invert elevations of storm and sanitary house connections to each block shall be noted on the drawing.

All street names, lot numbering and block identification shall be checked against the Registered Plan and corrected if required.

The “As-Constructed” revision note shall be placed on all drawings in the revision block. The title sheet of the Engineering Drawings shall be clearly marked with “As-constructed”.

The Contract Number, if applicable, shall be added to the drawings.

Tolerances

A maximum vertical plotting tolerance of 0.2 metres on the 1:50 vertical profile portion of the drawings and a maximum horizontal plotting tolerance of 1 metre on the 1:500 scale drawing shall be considered acceptable without replotting.

All sewer lengths are to be shown to the nearest 0.1 metres.

The information shown on the “As-Constructed” drawings may be checked by the Town at any time up to two years after final acceptance and if discrepancies are found between the information shown on the drawings and the field conditions, then the drawings will be returned for rechecking and further revision.

Appendix A: Standard Drawings



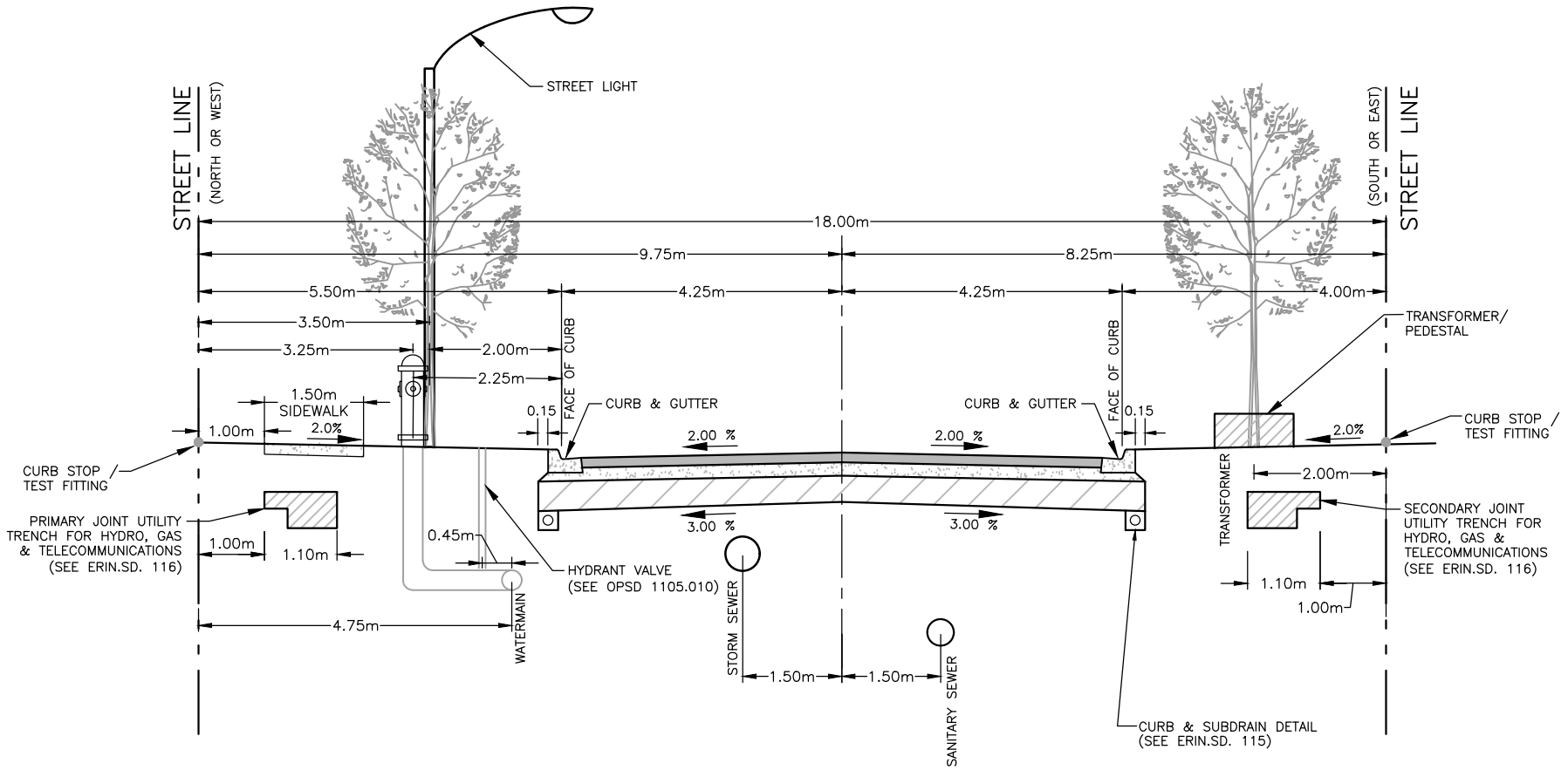

NOTE:

1. 18.0m CORRIDOR ONLY TO BE USED ON SUBDIVISIONS WITH DRAFT PLAN APPROVAL AS OF APRIL 2021.



**URBAN MINOR LOCAL
(8.5m ROAD ON 18.0m RIGHT-OF-WAY)**

| NO. | REVISIONS | DATE | APR'D |
|-----|-----------|------|-------|
| | | | |
| | | | |
| | | | |
| | | | |

SCALE: N.T.S.

DATE: NOV. 2021

**ERIN SD.
101**

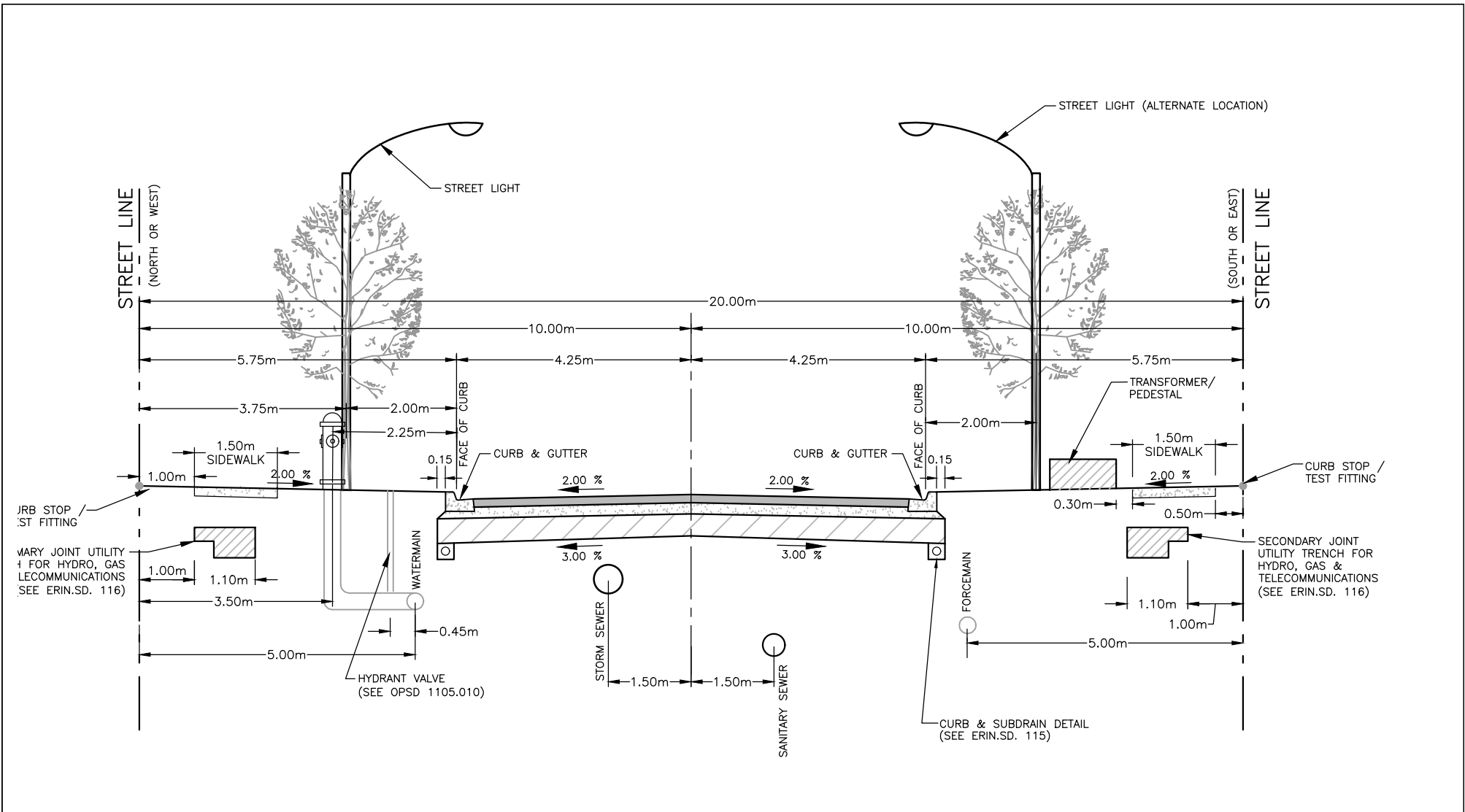

NOTE:
 1. WHERE MULTI-USE TRAIL OR BICYCLE LANES ARE REQUIRED THE ROW WIDTH SHALL BE INCREASED TO 26.0m

| | | | | |
|---|-----|-----------|------|----------------------------------|
| | | | | SCALE: N.T.S. |
| | | | | DATE: NOV. 2021 |
| URBAN/ SUBURBAN ROAD SECTION (8.5m ROAD ON 20.0m RIGHT-WAY) | | | | ERIN SD. 102 |
| | NO. | REVISIONS | DATE | |

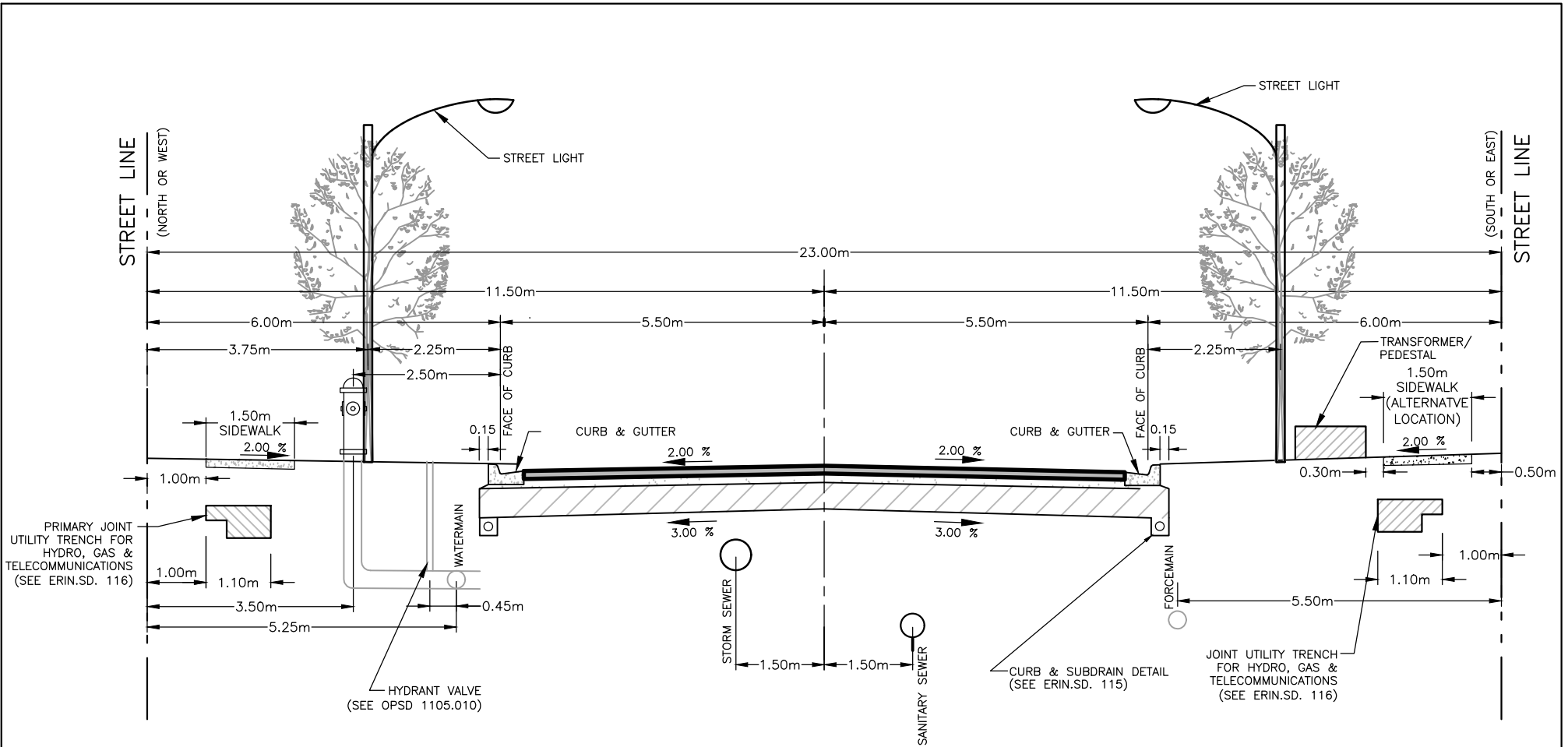

- NOTE:**
- WHERE MULTI-USE TRAIL OR BICYCLE LANES ARE REQUIRED THE ROW WIDTH SHALL BE INCREASED TO 26.0m



**MINOR COLLECTOR
(10.0m ROAD ON 23.0m RIGHT-OF-WAY)**

| NO. | REVISIONS | DATE | APR'D |
|-----|-----------|------|-------|
| | | | |
| | | | |
| | | | |

SCALE: N.T.S.
 DATE: NOV. 2021
**ERIN SD.
 103**

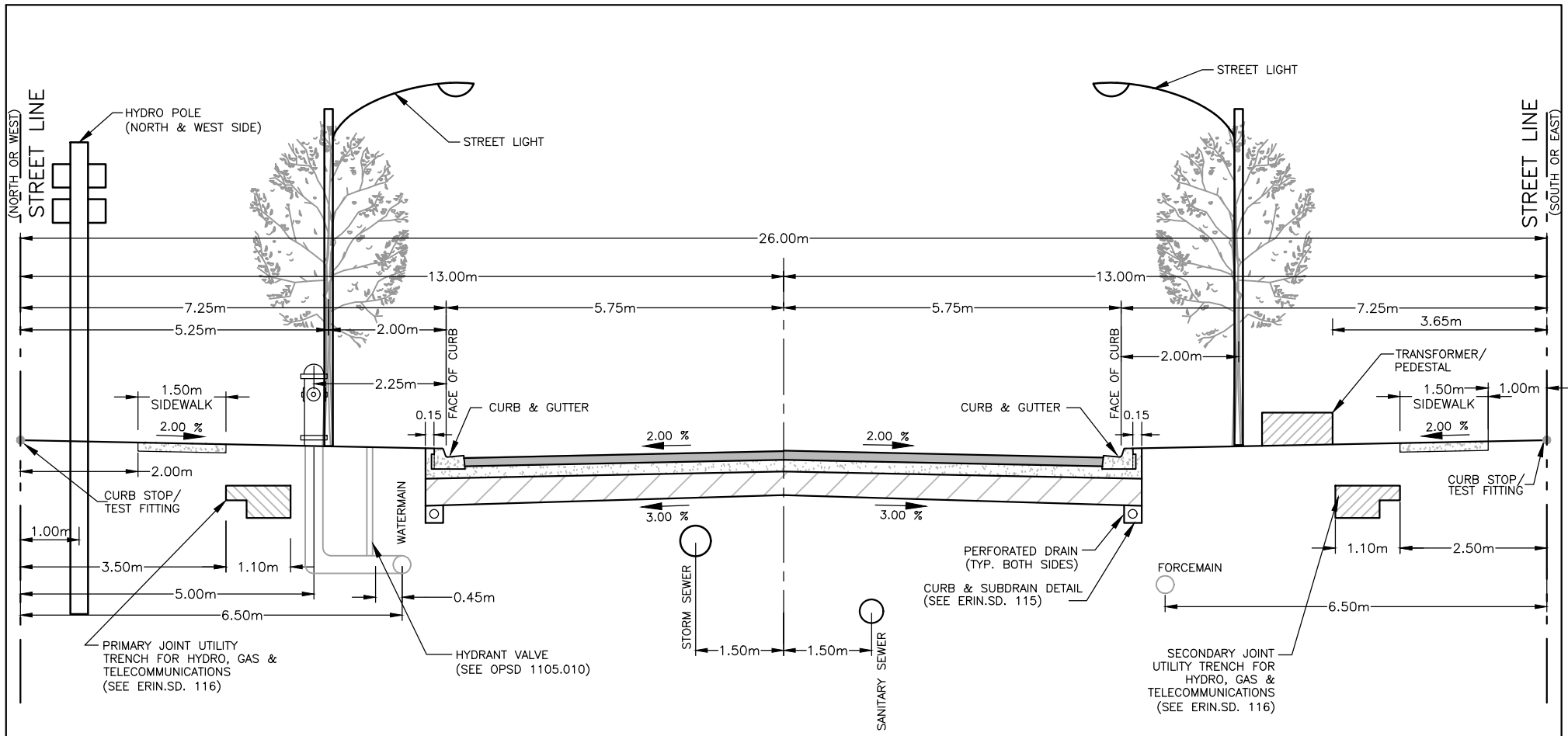

NOTE:
 1. WHERE MULTI-USE TRAIL OR BICYCLE LANES ARE REQUIRED THE ROW WIDTH SHALL BE INCREASED TO 30.0m

| | | | | | |
|---|-----|-----------|------|-------|----------------------------------|
| | | | | | SCALE: N.T.S. |
| | | | | | DATE: NOV. 2021 |
| 3-LANE MAJOR COLLECTOR (11.5m ROAD ON 26.0m RIGHT-OF-WAY) | | | | | ERIN SD. 104 |
| | NO. | REVISIONS | DATE | APR'D | |

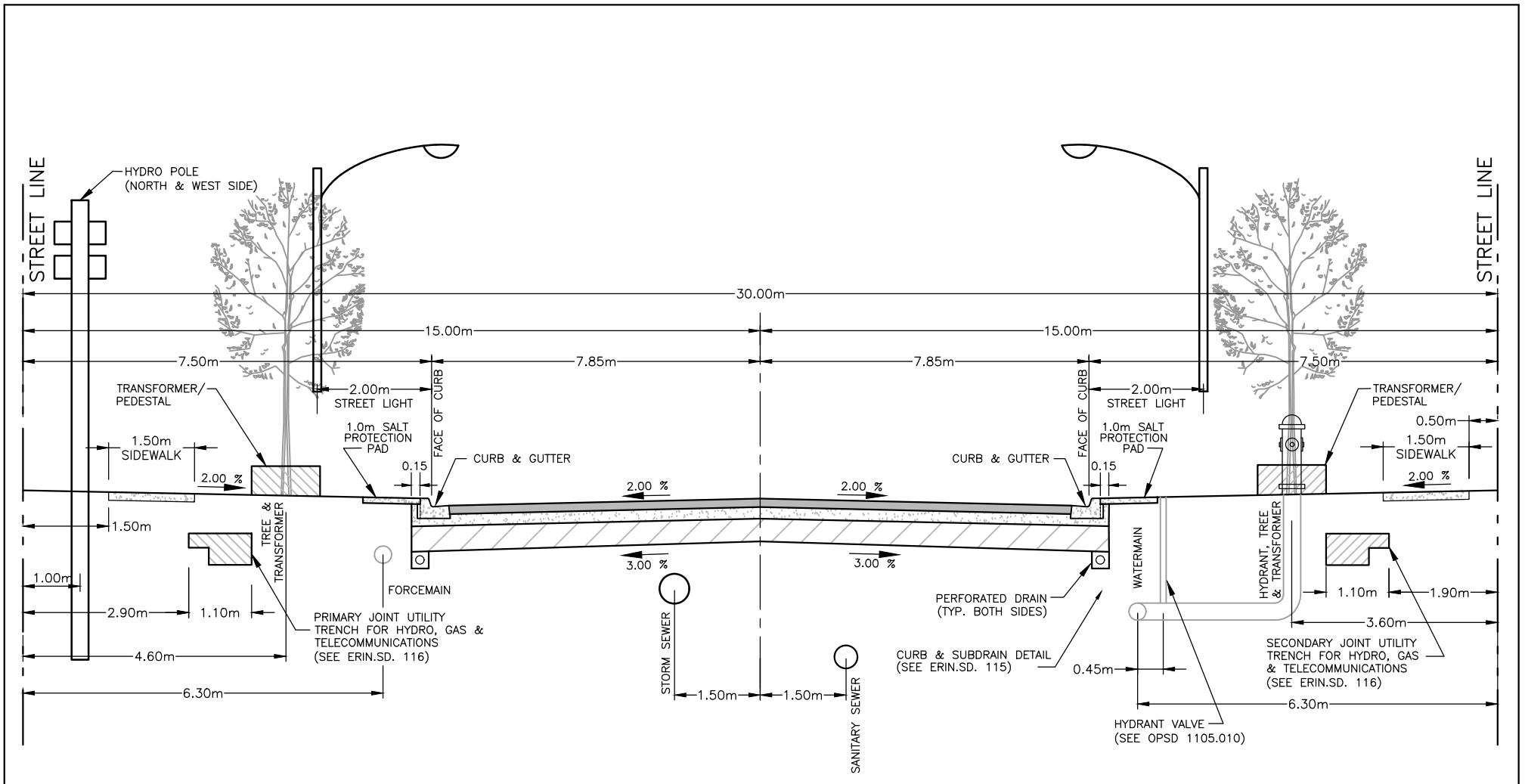

- NOTE:
1. CONCRETE BARRIER CURB WITH WIDE GUTTER TO BE INSTALLED
 2. WHERE MULTI-USE TRAIL OR BICYCLE LANES ARE REQUIRED THE ROW WIDTH SHALL BE INCREASED TO 36.0m

| | | | | | |
|--|-----|-----------|------|-------|-------------------------------|
|  TOWN OF ERIN | | | | | SCALE: N.T.S. |
| | | | | | DATE: NOV. 2021 |
| 4 LANE ARTERIAL (15.7m ROAD ON 30.0m RIGHT-OF-WAY) | | | | | ERIN SD. 105 |
| | NO. | REVISIONS | DATE | APR'D | |
| | | | | | |

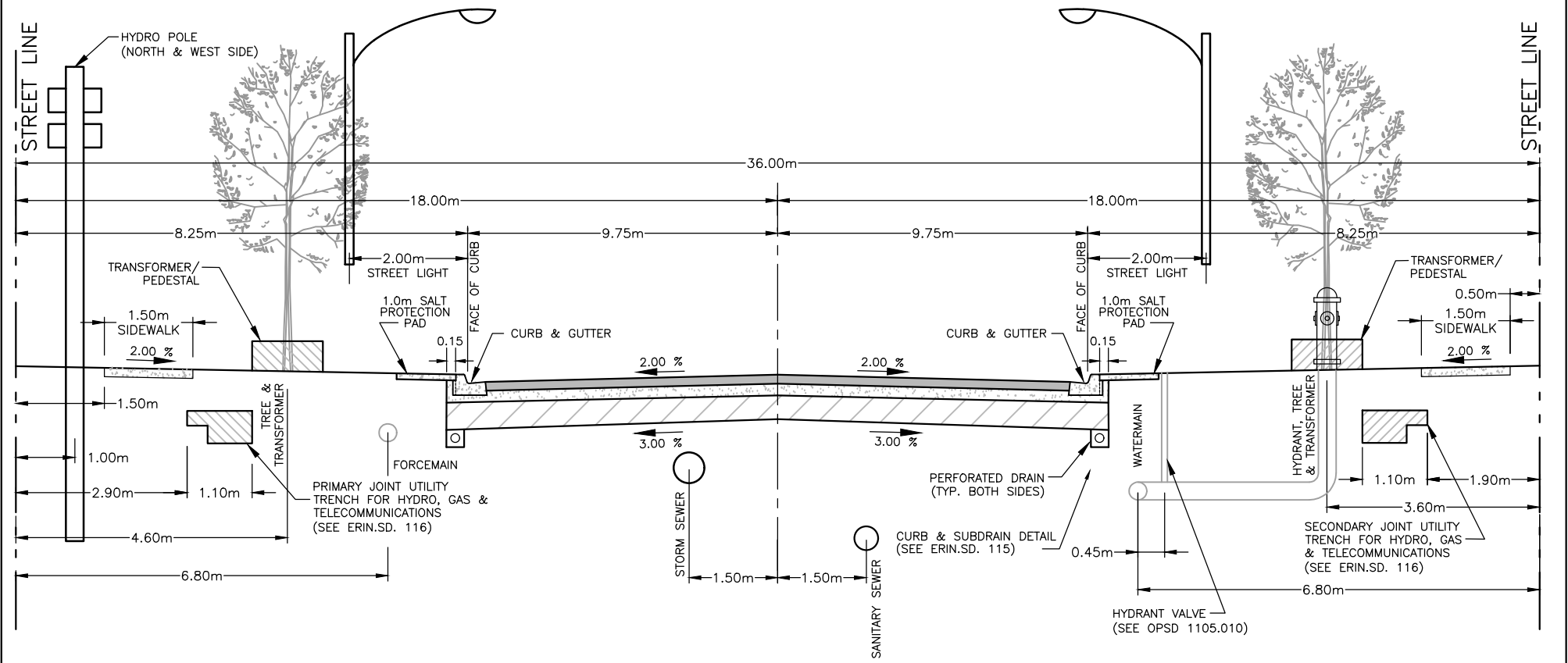

- NOTE:**
1. CONCRETE BARRIER CURB WITH WIDE GUTTER TO BE INSTALLED
 2. WHERE MULTI-USE TRAIL OR BICYCLE LANES ARE REQUIRED THE ROW WIDTH SHALL BE INCREASED TO 40.0m

| | | | | | |
|---|-----|-----------|------|-------|---------------------------------------|
| <p>TOWN OF ERIN</p> | | | | | SCALE: N.T.S. |
| | | | | | DATE: NOV. 2021 |
| <p>5 LANE ARTERIAL (19.5m ROAD ON 36.0m RIGHT-OF-WAY)</p> | | | | | <p>ERIN SD. 106</p> |
| | NO. | REVISIONS | DATE | APR'D | |

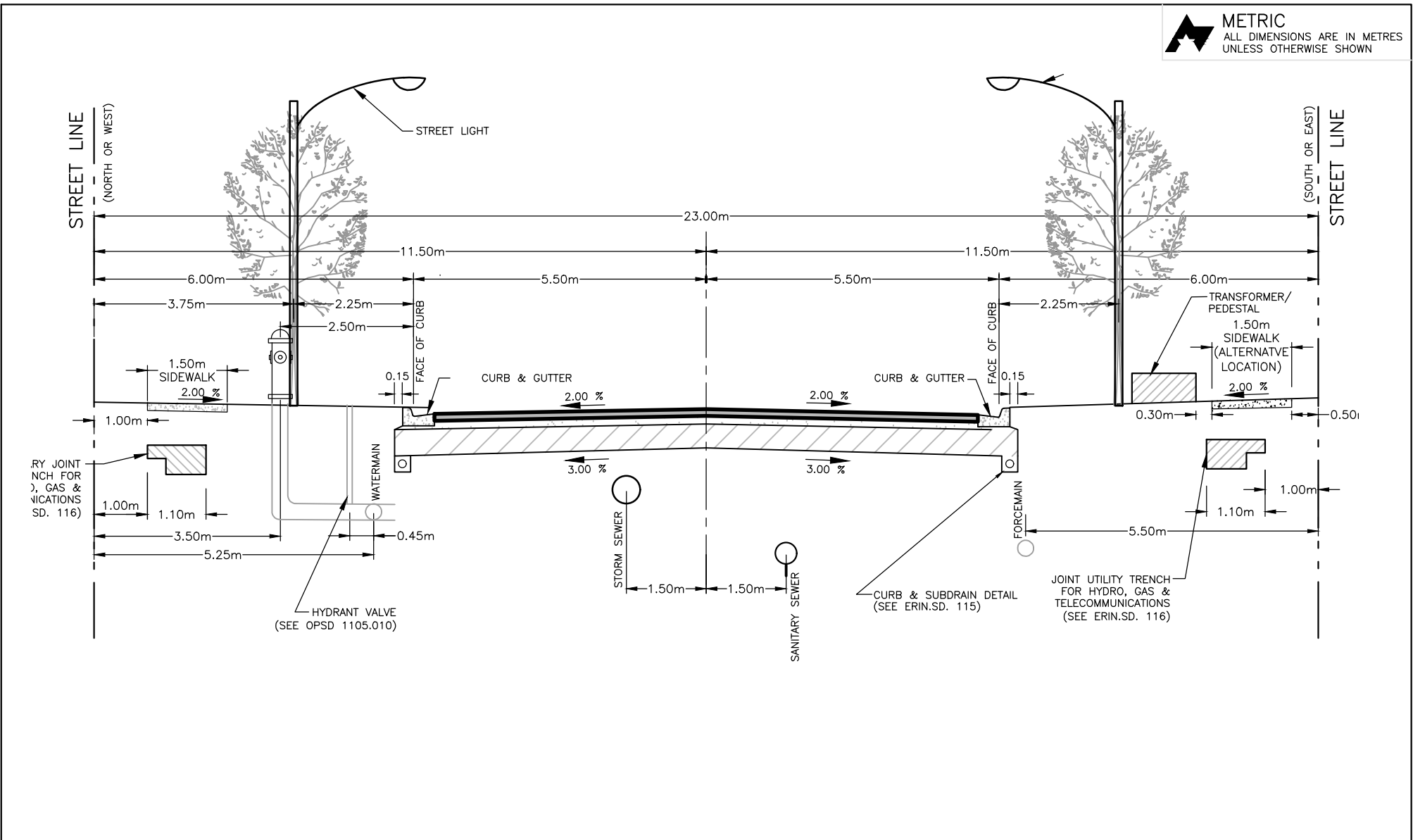

**2 LANE INDUSTRIAL
(10.0m ROAD ON 23.0m RIGHT-OF-WAY)**

| | | | |
|-----|-----------|------|-------|
| NO. | REVISIONS | DATE | APR'D |
| | | | |
| | | | |
| | | | |
| | | | |

SCALE: N.T.S.
DATE: NOV. 2021
**ERIN SD.
107**

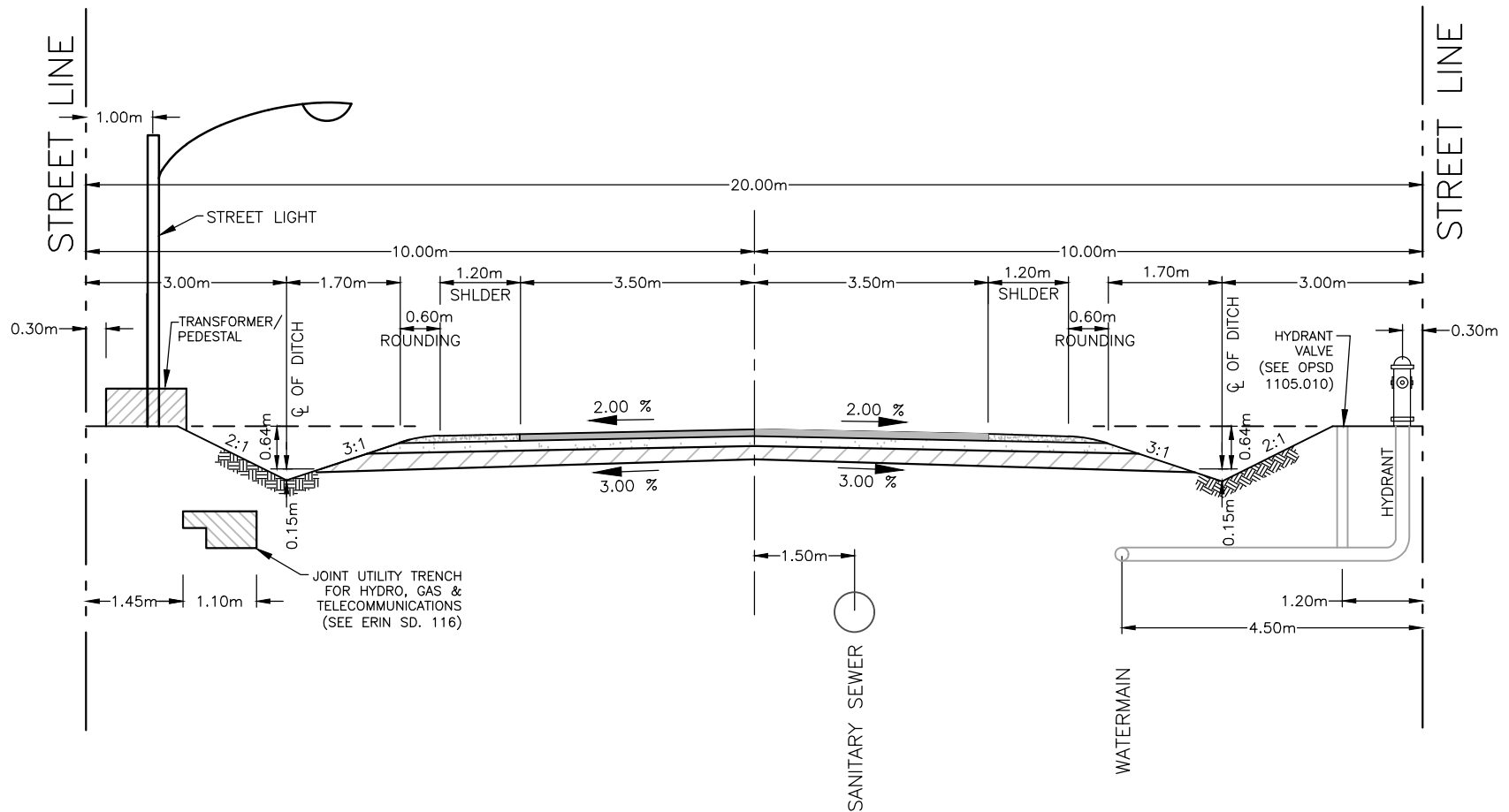

NOTE:

1. ALL DITCH INVERTS TO BE CONSTRUCTED TO A MINIMUM 0.15m BELOW THE ROAD GRANULAR SUB-BASE. IF THIS IS NOT POSSIBLE, THEN A 100mmØ PERFORATED SUB-DRAIN WRAPPED IN FILTER CLOTH IS TO BE INSTALLED BELOW THE DITCH. DRAINAGE TO A POSITIVE OUTLET.



RURAL
(7.0m ROAD ON 20.0m RIGHT-OF-WAY)

| NO. | REVISIONS | DATE | APR'D |
|-----|-----------|------|-------|
| | | | |
| | | | |
| | | | |
| | | | |

SCALE: N.T.S.

DATE: NOV. 2021

ERIN SD.
108

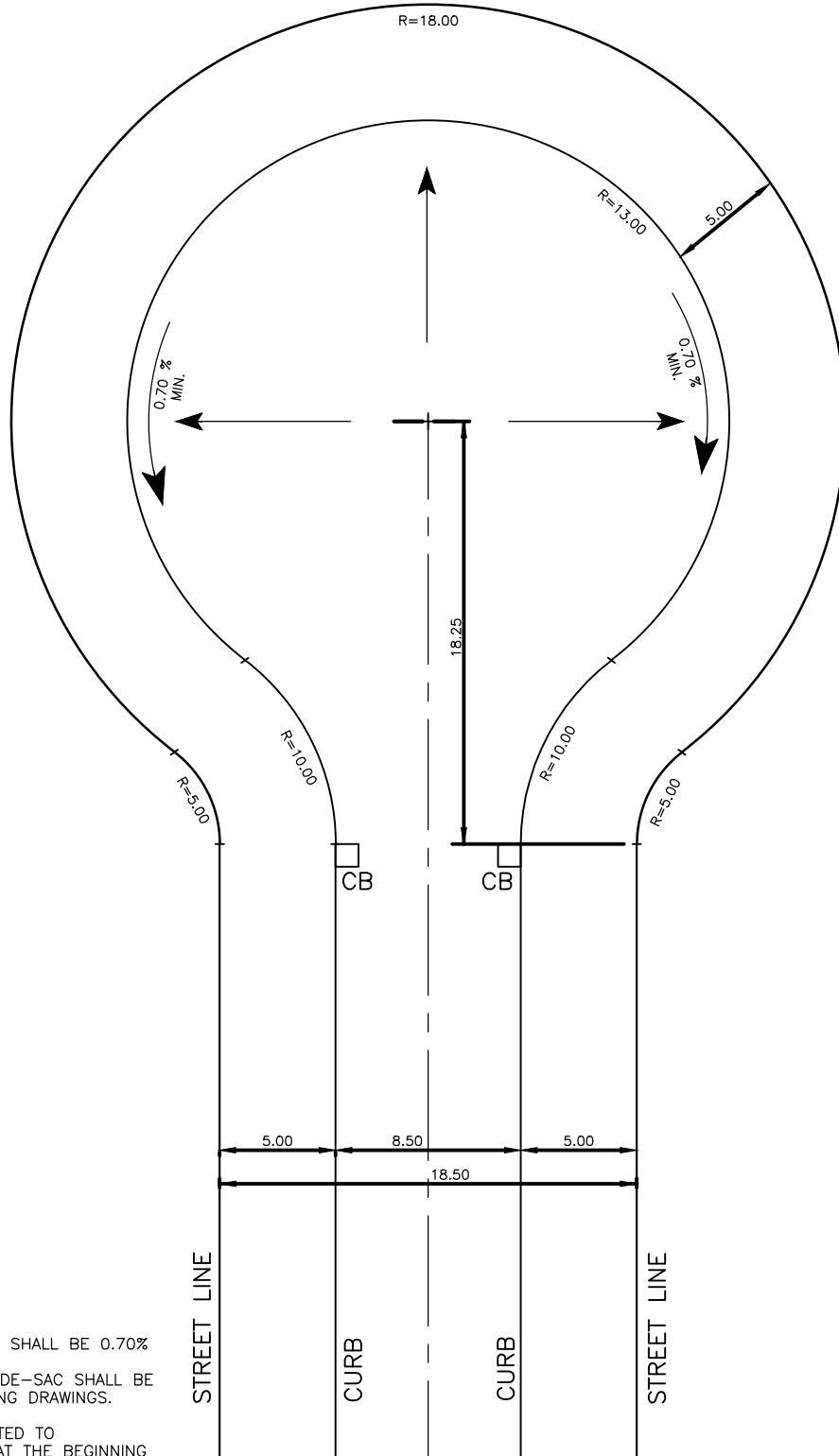

NOTES:

1. MINIMUM GUTTER GRADE SHALL BE 0.70%
2. GRADING AROUND CUL-DE-SAC SHALL BE DETAILED ON ENGINEERING DRAWINGS.
3. DRAINAGE TO BE DIRECTED TO CATCHBASINS LOCATED AT THE BEGINNING OF THE BULB.
4. MAXIMUM 40 UNITS ON CUL-DE-SAC.



**TYPICAL MINOR LOCAL CUL-DE-SAC
(18.5m ROAD ALLOWANCE)**



| NO. | REVISIONS | DATE | APR'D |
|-----|-----------|------|-------|
| | | | |
| | | | |
| | | | |

SCALE: N.T.S.
DATE: NOV. 2021

**ERIN SD.
109**

CUL-DE-SAC STANDARD

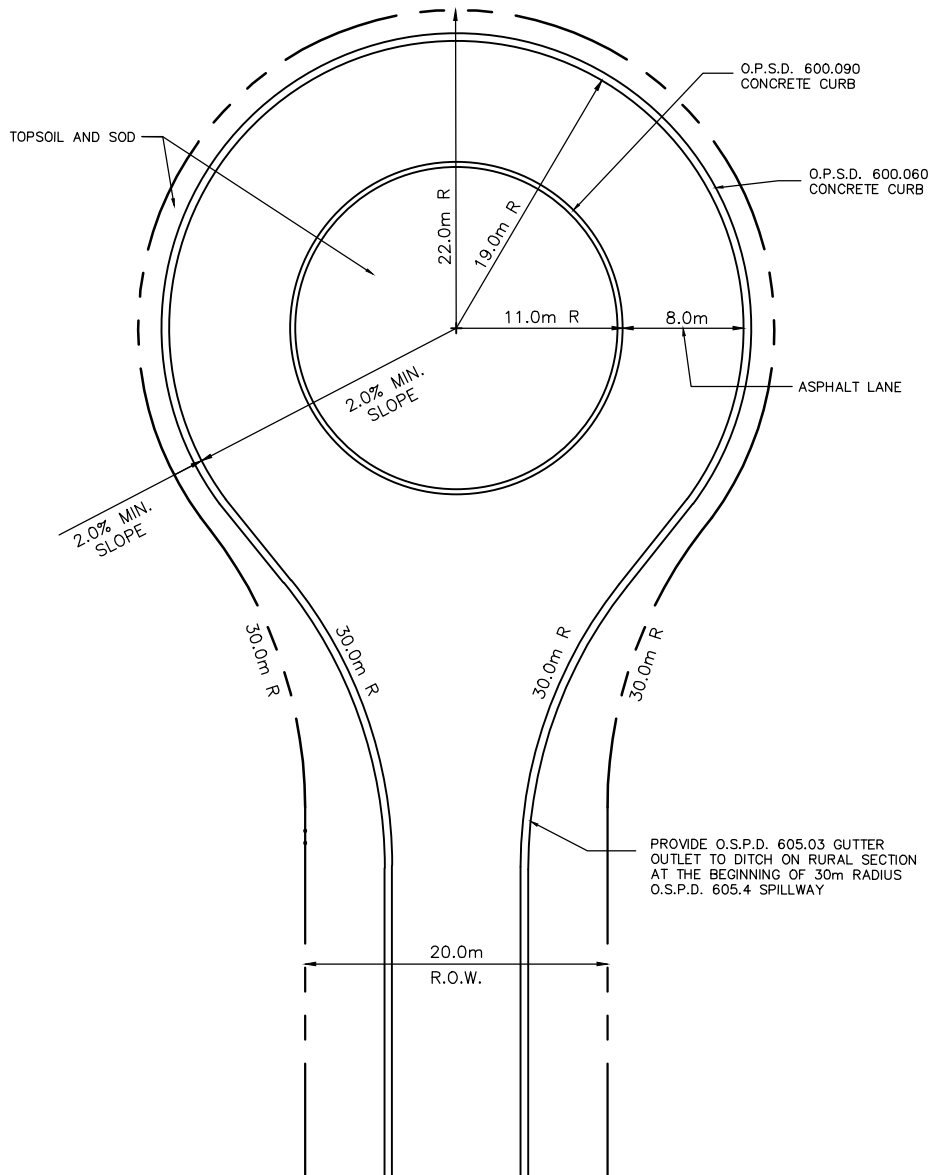

TOWN OF
ERIN

CUL-DE-SAC STANDARD



METRIC
ALL DIMENSIONS ARE
IN METRES UNLESS
OTHERWISE SHOWN

NO.

REVISIONS

DATE

APR'D

SCALE: N.T.S.
DATE: NOV. 2021

ERIN SD.
110

LOCAL ROAD 'ELBOW' DESIGN

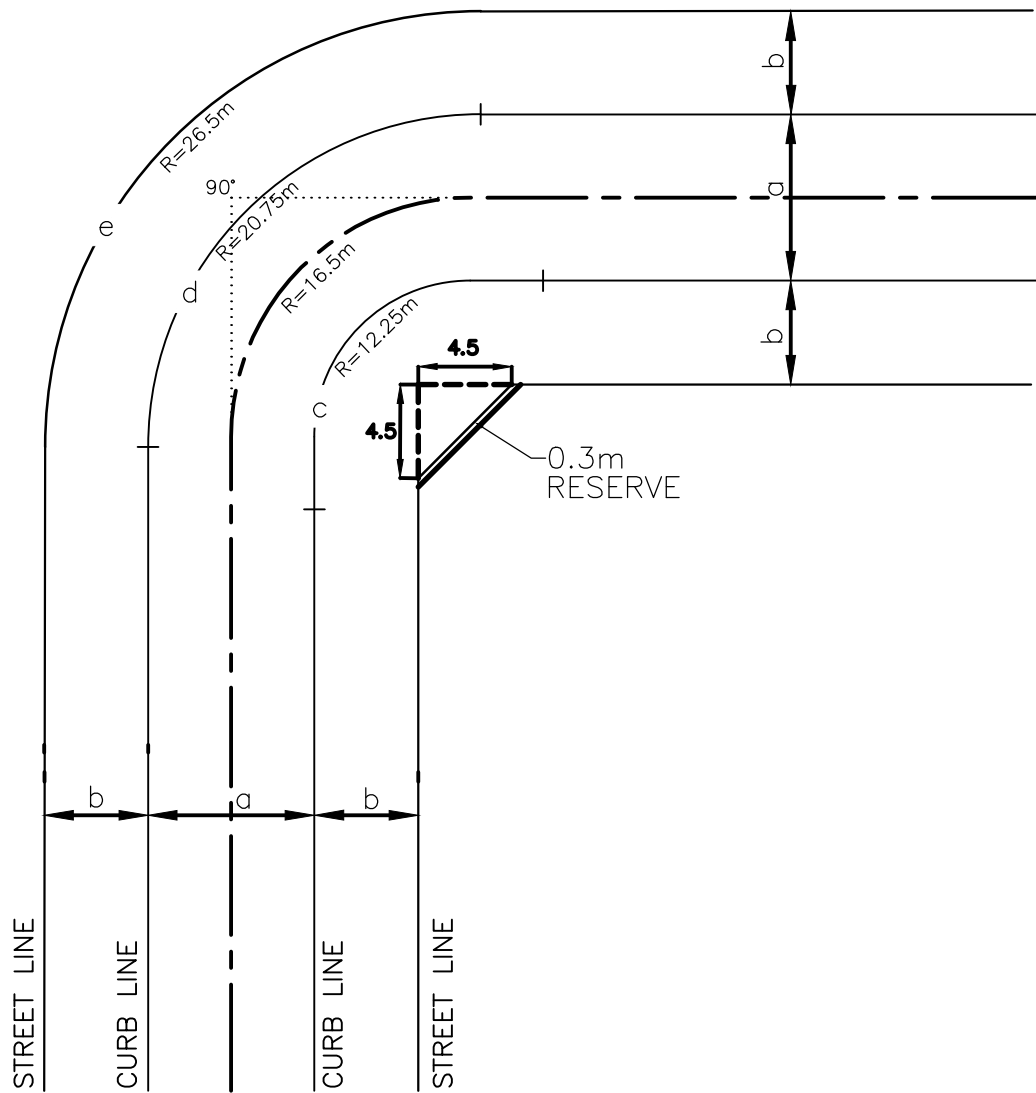

| LOCAL 20.0m R.O.W. | |
|-----------------------|--------|
| a | 8.50m |
| b | 5.75m |
| c | 12.25m |
| d | 20.75m |
| e | 26.5m |



ROAD 'ELBOW' DESIGN



METRIC
ALL DIMENSIONS ARE
IN METRES UNLESS
OTHERWISE SHOWN

| NO. | REVISIONS | DATE | APR'D |
|-----|-----------|------|-------|
| | | | |
| | | | |
| | | | |

SCALE: N.T.S.
DATE: NOV. 2021
ERIN SD.
111A

MINOR COLLECTOR ROAD 'ELBOW' DESIGN

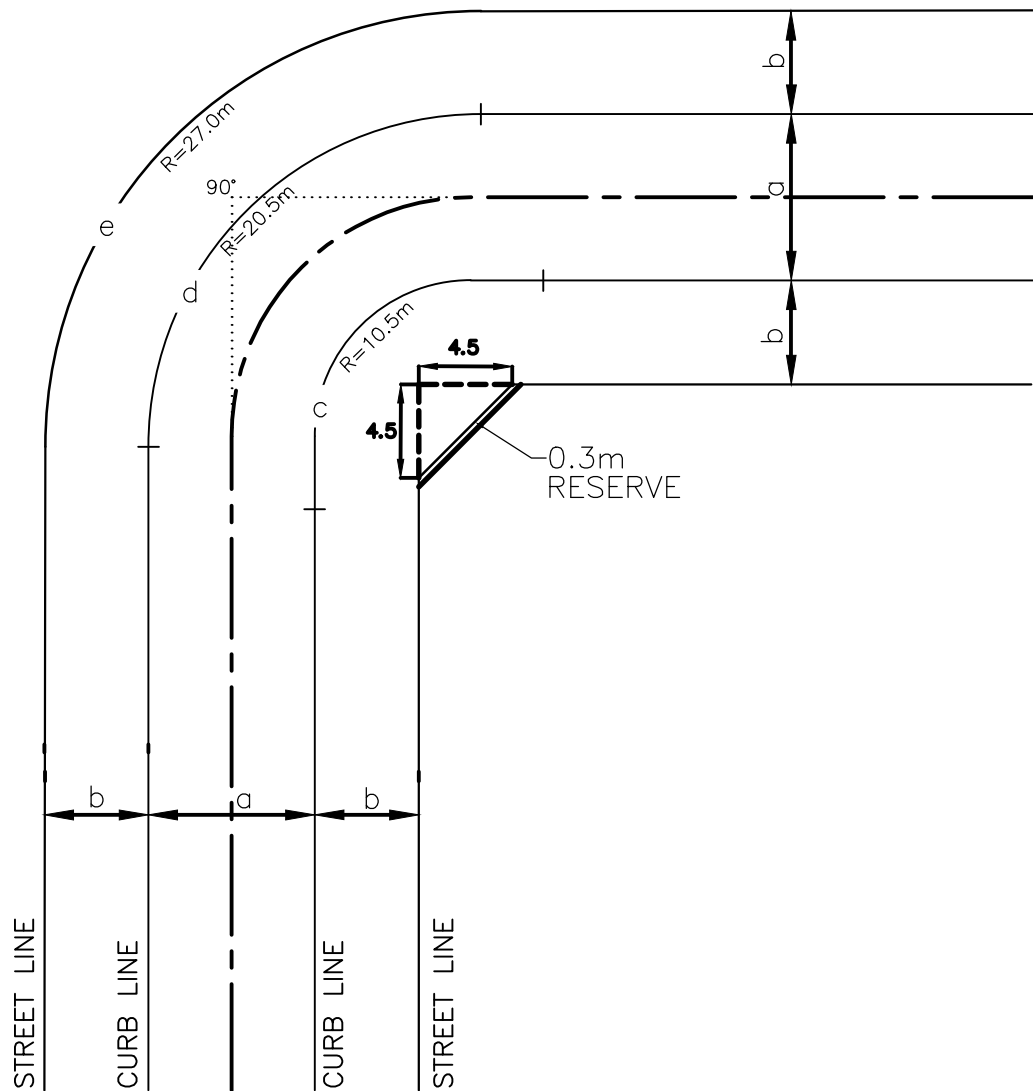

| MINOR COLLECTOR 23.0m R.O.W. | |
|---------------------------------|-------|
| a | 10.0m |
| b | 6.5m |
| c | 10.5m |
| d | 20.5m |
| e | 27.0m |



ROAD 'ELBOW' DESIGN



METRIC
ALL DIMENSIONS ARE
IN METRES UNLESS
OTHERWISE SHOWN

| NO. | REVISIONS | DATE | APR'D |
|-----|-----------|------|-------|
| | | | |
| | | | |
| | | | |

SCALE: N.T.S.
DATE: NOV. 2021
ERIN SD.
111B

INDUSTRIAL ROAD 'ELBOW' DESIGN

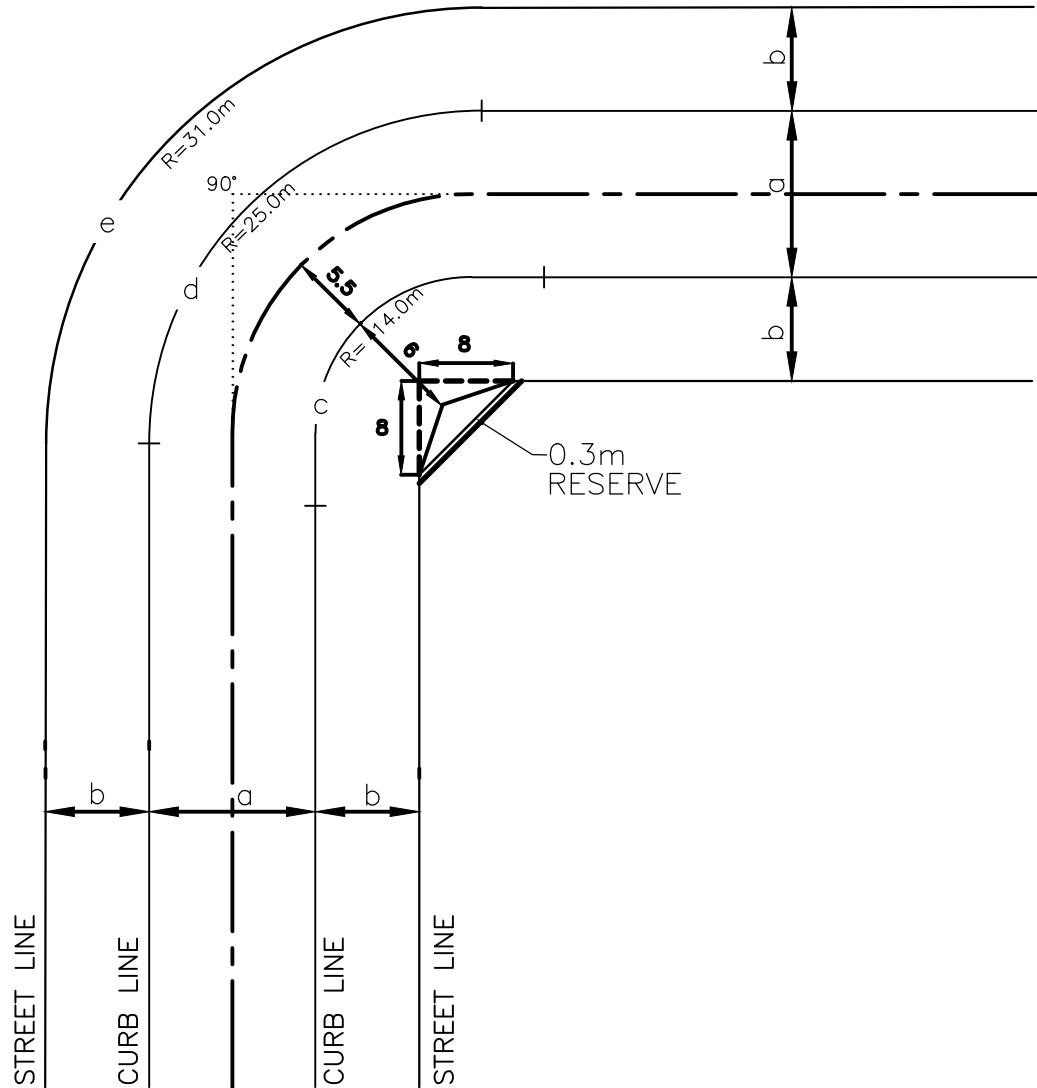

| INDUSTRIAL 23.0m R.O.W. | |
|----------------------------|-------|
| a | 11.0m |
| b | 6.0m |
| c | 14.0m |
| d | 25.0m |
| e | 31.0m |

TOWN OF
ERIN

ROAD 'ELBOW' DESIGN



METRIC
ALL DIMENSIONS ARE
IN METRES UNLESS
OTHERWISE SHOWN

NO.

REVISIONS

DATE

APR'D

SCALE: N.T.S.
DATE: NOV. 2021

ERIN SD.
111C

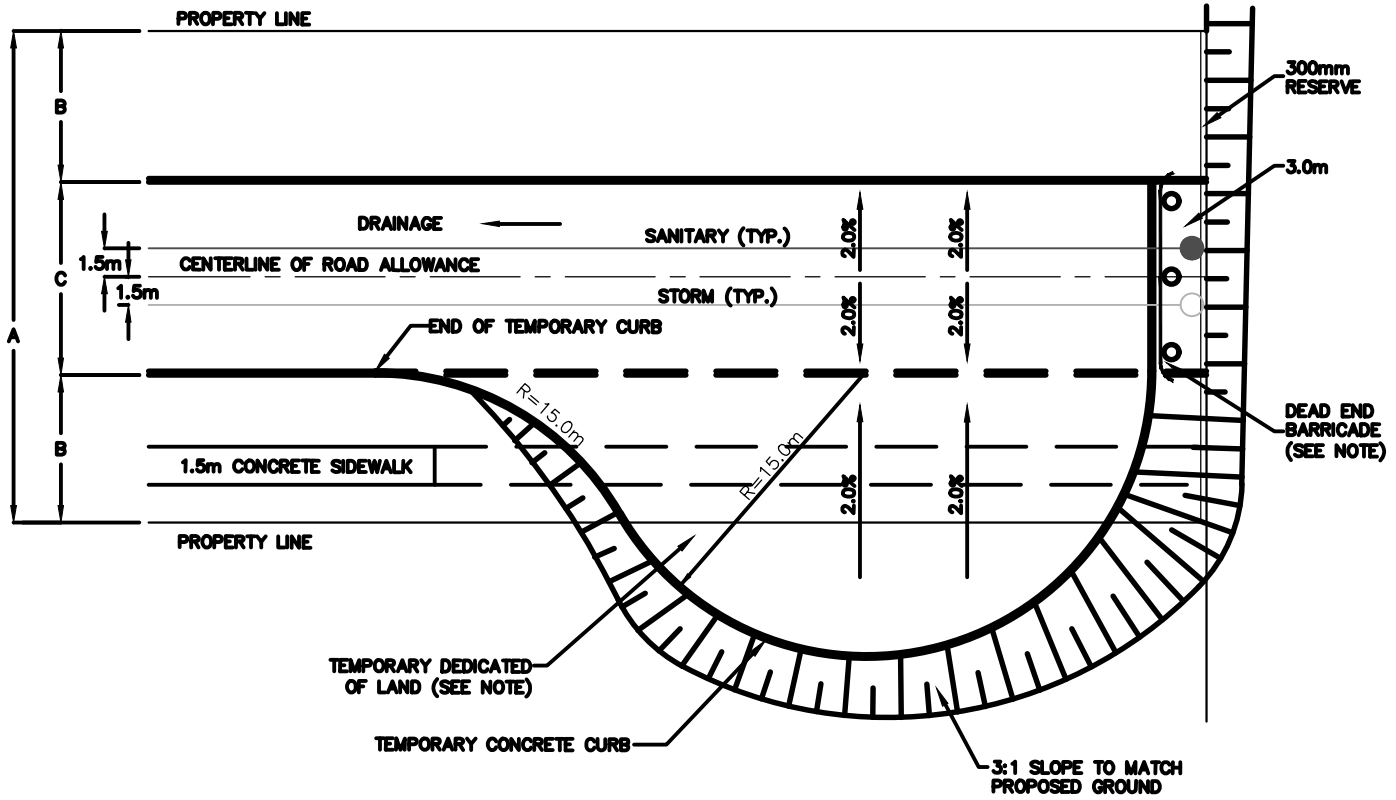

NOTES:

1. ALL CURB AND GUTTER SHALL BE TWO-STAGE CONCRETE BARRIER TYPE AS PER TOWN STANDARD.
2. ONLY TO BE USED WHEN ROAD IS TO BE EXTENDED IN A SHORT PERIOD OF TIME (E.G., 2 YEARS).
3. TEMPORARY CURB CAN BE SINGLE STAGE.
4. DEAD END BARRICADE PER OPSD 906.01 COMPLETE WITH ADDITIONAL 500mm x 500mm BLACK ON WHITE SIGN NOTING - TEMPORARY ONLY - LOCATION OF FUTURE ROAD.
5. TEMPORARY LAND DEDICATED VIA BLOCK ON PLAN.

| A | B | C |
|----|------|------|
| 20 | 5.75 | 8.50 |
| 18 | 5.00 | 8.00 |



TEMPORARY CUL-DE-SAC



| NO. | REVISIONS | DATE | APR'D |
|-----|-----------|------|-------|
| | | | |
| | | | |
| | | | |

SCALE: N.T.S.
DATE: NOV. 2021

**ERIN SD.
112**



METRIC
ALL DIMENSIONS ARE IN METRES
UNLESS OTHERWISE SHOWN

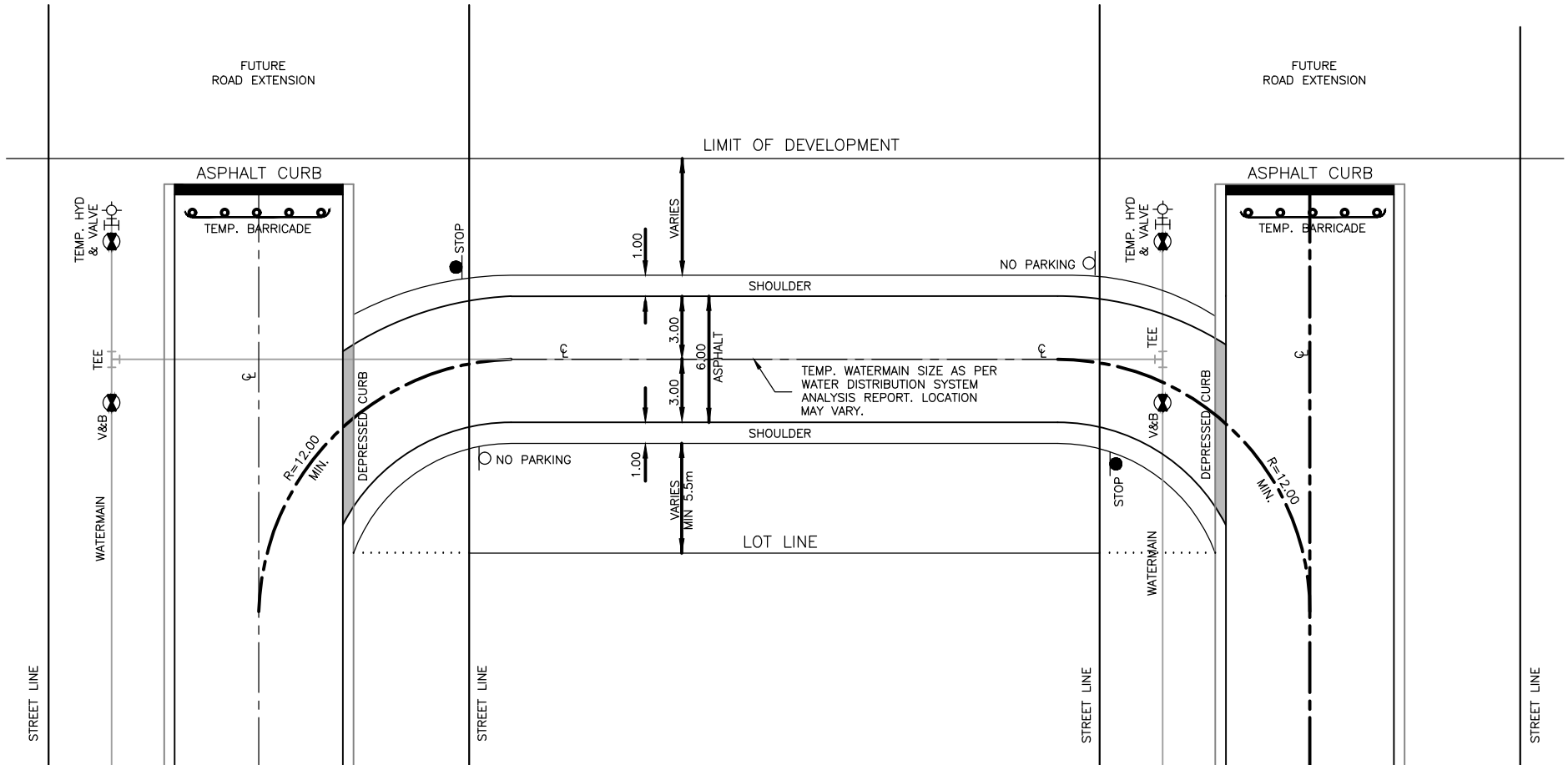

NOTE:
1. REFER TO ERIN.SD. 200.14 FOR TYPICAL TEMPORARY ROAD CROSS-SECTIONS



**TEMPORARY ROAD CONNECTING
PARALLEL STREETS**

| | | | | |
|-----|-----------|------|-------|--|
| | | | | |
| | | | | |
| | | | | |
| | | | | |
| | | | | |
| NO. | REVISIONS | DATE | APR'D | |

SCALE: N.T.S.
DATE: NOV. 2021

**ERIN SD.
113**

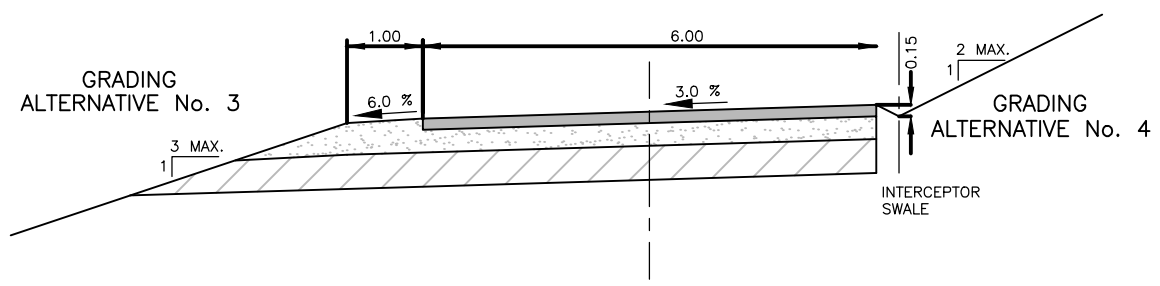
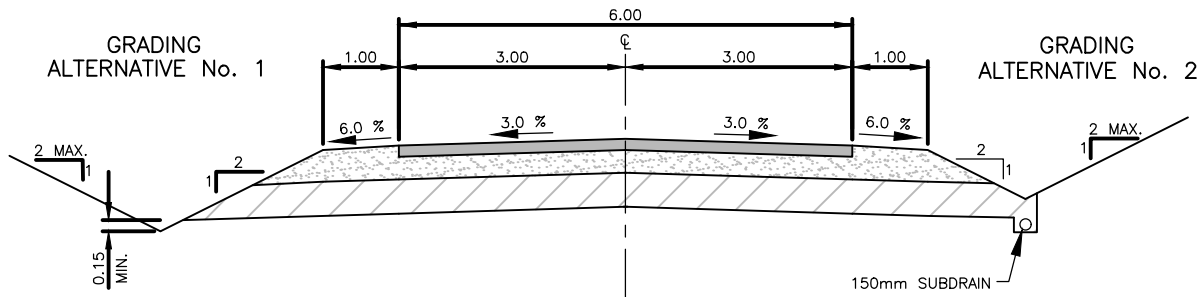

NOTE:

1. REFER TO ERIN SD. 113 FOR HORIZONTAL GEOMETRY OF TEMPORARY ROAD.



TYPICAL TEMPORARY ROAD CROSS-SECTIONS

| | | | | |
|---|-----|-----------|------|---------------------|
|  METRIC ALL DIMENSIONS ARE IN METRES UNLESS OTHERWISE SHOWN | | | | SCALE: N.T.S. |
| | | | | DATE: NOV. 2021 |
| | NO. | REVISIONS | DATE | APR'D |
| | | | | ERIN SD. 114 |

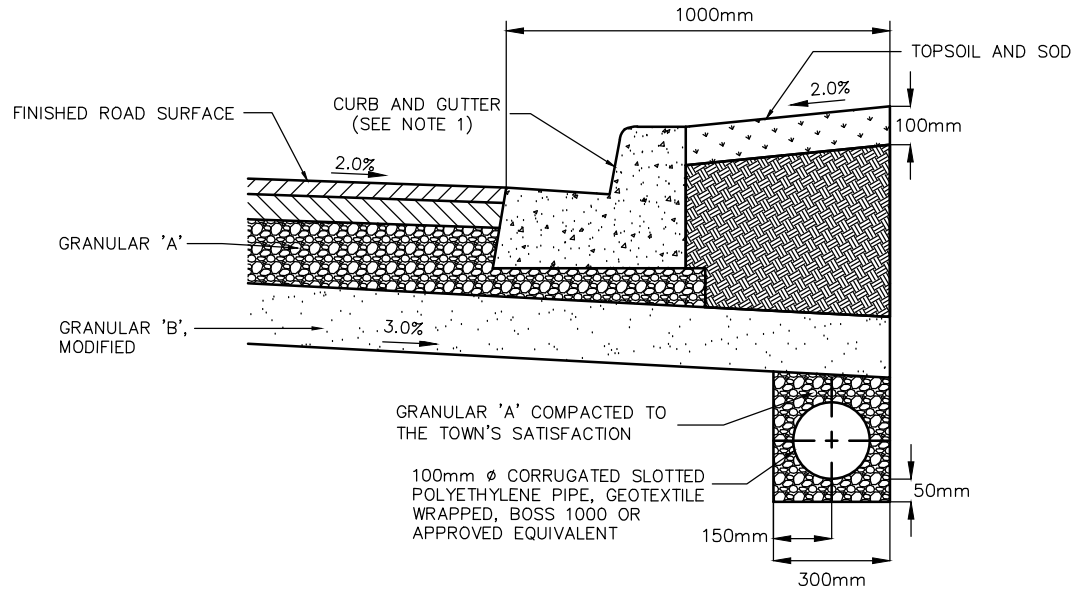

NOTES:

1. ALL CONNECTIONS TO CATCHBASINS TO BE MORTARED AT THE INSIDE AND OUTSIDE OF THE CATCHBASIN WALLS.
2. GEOTEXTILE WRAPPED SUBDRAIN PIPERS SHALL NOT BE EXPOSED TO SUNLIGHT OVER A PERIOD OF 10 HOURS.
3. THE SUBDRAIN SHALL BE INSTALLED IN A RECTANGULAR TRENCH.
4. THE LOCATION OF THE SUBDRAINS HORIZONTALLY PLUS OR MINUS (\pm) 50mm.
5. ALL THE SUBDRAINS SHALL BE CHECKED WITH A VIDEO CAMERA INSPECTION AT THE OWNER'S EXPENSE. THE TOWN MAY REQUIRE ADDITIONAL INSPECTIONS IF THERE ARE ANY UTILITY CROSSINGS SUBSEQUENT TO THE INSPECTIONS. ADDITIONAL INSPECTIONS MAY BE REQUIRED UP UNTIL FINAL ACCEPTANCE AS DETERMINED BY THE TOWN.
6. THE SUBDRAIN SHALL MAINTAIN ITS ROUND SHAPE TO THE SATISFACTION OF THE TOWN.
7. THE SUBDRAINS SHALL BE CONNECTED TO THE STORM SEWER STRUCTURES AT THE UPSTREAM AND DOWNSTREAM ENDS.
8. ALL SUBDRAINS SHALL BE CONNECTED TO STORM SEWER STRUCTURES AT THE UPSTREAM AND DOWNSTREAM ENDS.
9. SUBDRAINS EXITING STRUCTURES SHALL HAVE A REMOVABLE PLUG TO PREVENT SILTATION OF THE SUBDRAIN.



CURB AND SUBDRAIN DETAIL

| NO. | REVISIONS | DATE | APR'D |
|-----|-----------|------|-------|
| | | | |
| | | | |
| | | | |
| | | | |

SCALE: N.T.S.

DATE: NOV. 2021

**ERIN SD.
115**

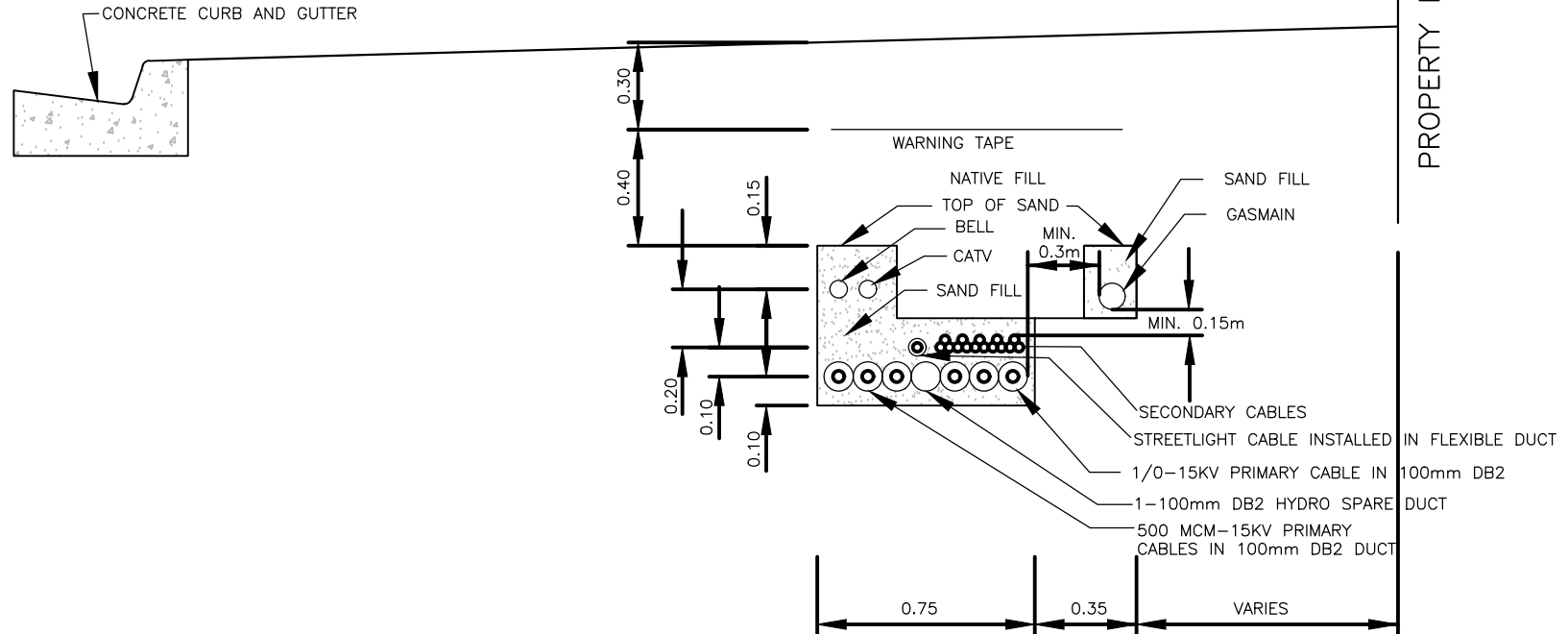

NOTES:

1. CROSSING LOCATION AND NUMBER OF DUCTS TO BE STATED ON ALL CONSTRUCTION DRAWINGS.
2. ALL DUCTS AND SPACING AS PER UTILITY SPECIFICATIONS.
3. BACKFILL TO BE COMPACTED AND VERIFIED TO 98 % STANDARD PROCTOR.



**DIRECT BURIED – JOINT USE TRENCH
 (FOR SUBDIVISIONS ONLY)**

| | | | |
|-----|-----------|------|-------|
| | | | |
| | | | |
| | | | |
| | | | |
| NO. | REVISIONS | DATE | APR'D |

SCALE: N.T.S.

DATE: NOV. 2021

**ERIN SD.
 116**

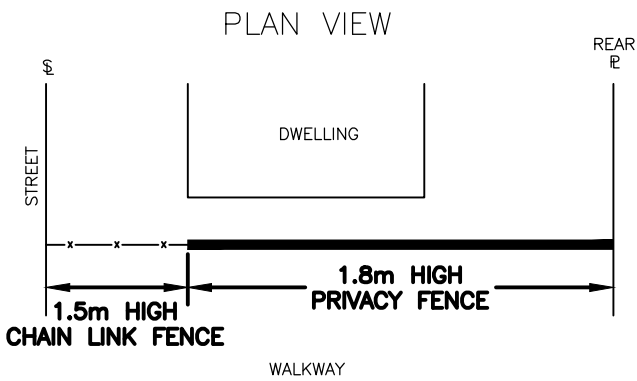
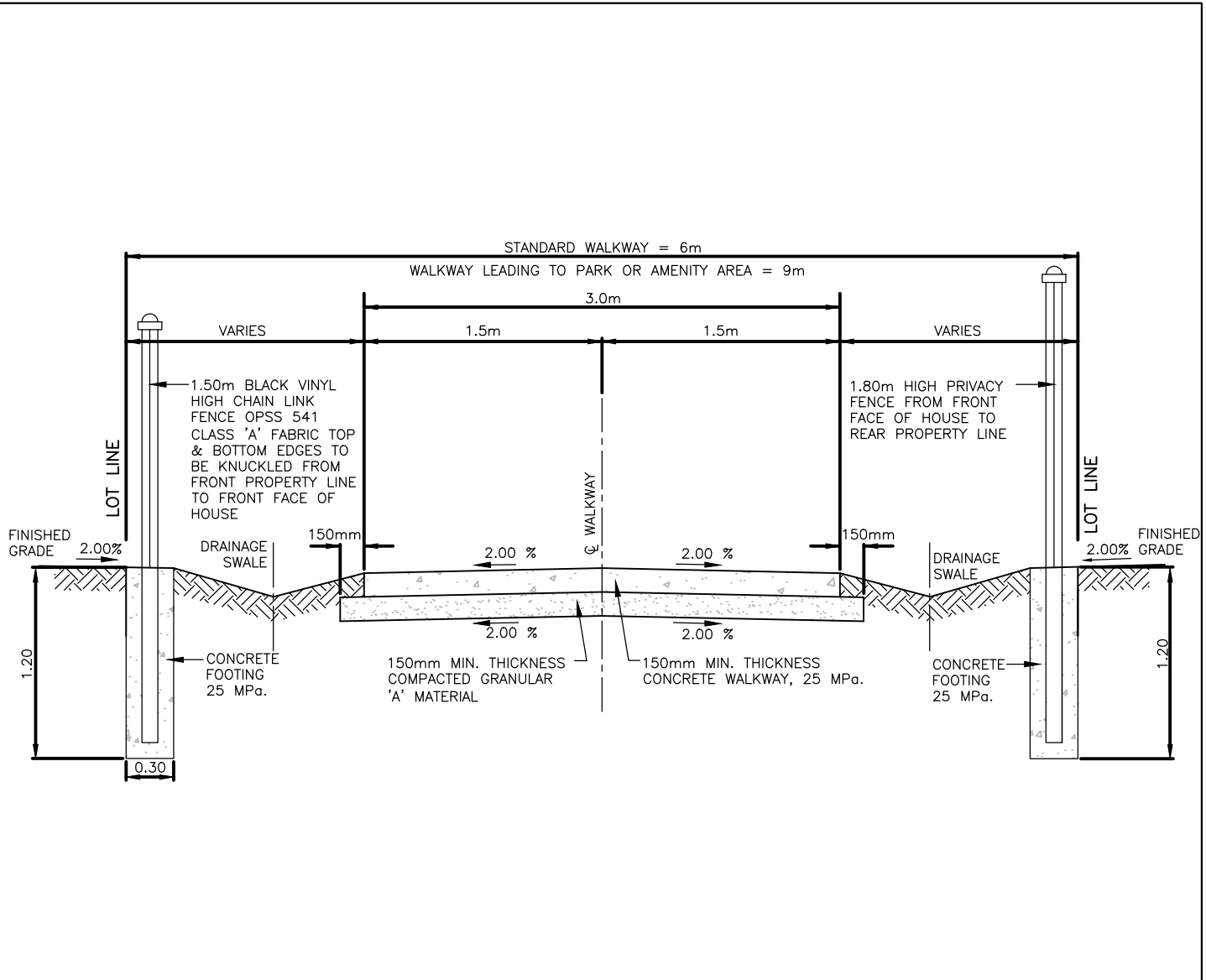

NOTES:

1. BLACK VINYL CHAIN LINK FENCE WITH TOP RAIL TO OPSS 541 CLASS 'A' FABRIC. SEE OPSD 900.01 FOR ADDITIONAL DETAILS.
2. CONCRETE WALKWAY TO OPSS 351 (25 MPa. CONCRETE). SEE OPSD 303.03 FOR ADDITIONAL DETAILS. EXPANSION JOINTS BETWEEN CURBS & WALKWAY AND AT 6.00 INTERVAL ALONG WALKWAY. DUMMY JOINTS AT 1.50 INTERVALS.
3. CONCRETE CURB TO OPSS 353 (25 MPa. CONCRETE). TRANSVERSE JOINT SPACING TO COINCIDE WITH THAT OF WALKWAY.
4. A MINIMUM 1.00% GRADE MUST BE MAINTAINED ALONG WALKWAYS, WITH DRAINAGE OUTLETS AS REQUIRED BY THE TOWN.
5. WALKWAY LIGHTING DESIGN TO BE APPROVED BY THE TOWN.



TYPICAL WALKWAY CROSS-SECTION

| | | | | |
|---|-----------|------|-------|-------------------------------|
|  METRIC ALL DIMENSIONS ARE IN METRES UNLESS OTHERWISE SHOWN | | | | SCALE: N.T.S. |
| | | | | DATE: NOV. 2021 |
| NO. | REVISIONS | DATE | APR'D | ERIN SD. 118 |
| | | | | |

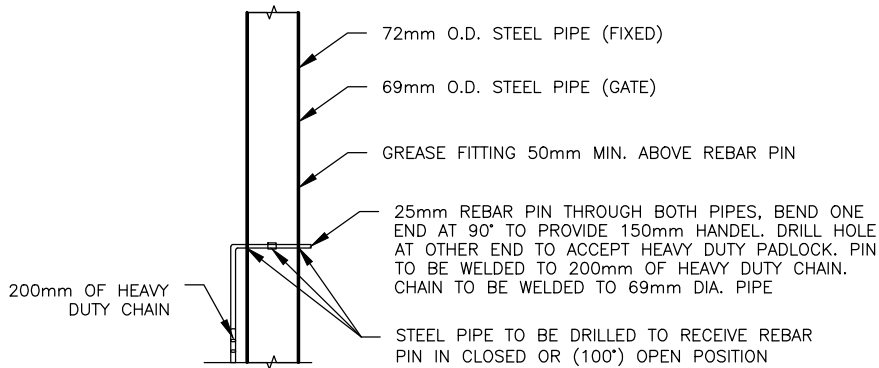
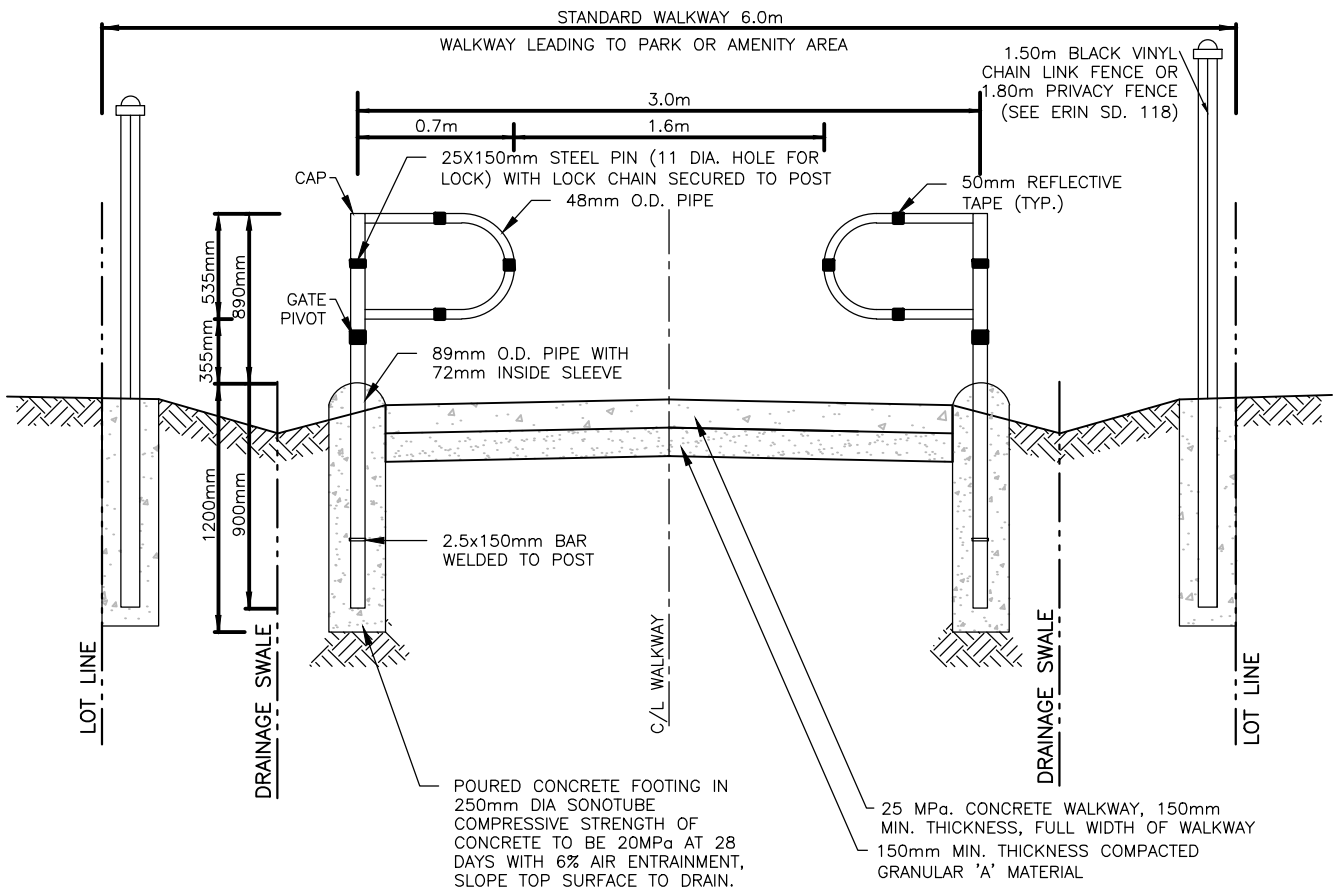

LOCKING DEVICE

NOTES

1. ALL JOINTS WELDED.
2. GATES & POSTS TO BE PRE-MANUFACTURED AND HOT DIPPED GALVANIZED.
3. FENCE AS PER ERIN SD. 118.
4. HINGE PINS TO BE 19mm ϕ STAINLESS STEEL BOLTS WITH LOCK NUTS WELDED.



WALKWAY GATE DETAIL

METRIC
ALL DIMENSIONS ARE
IN METRES UNLESS
OTHERWISE SHOWN

NO.

REVISIONS

DATE

APR'D

SCALE: N.T.S.
DATE: NOV. 2021

ERIN SD.
119

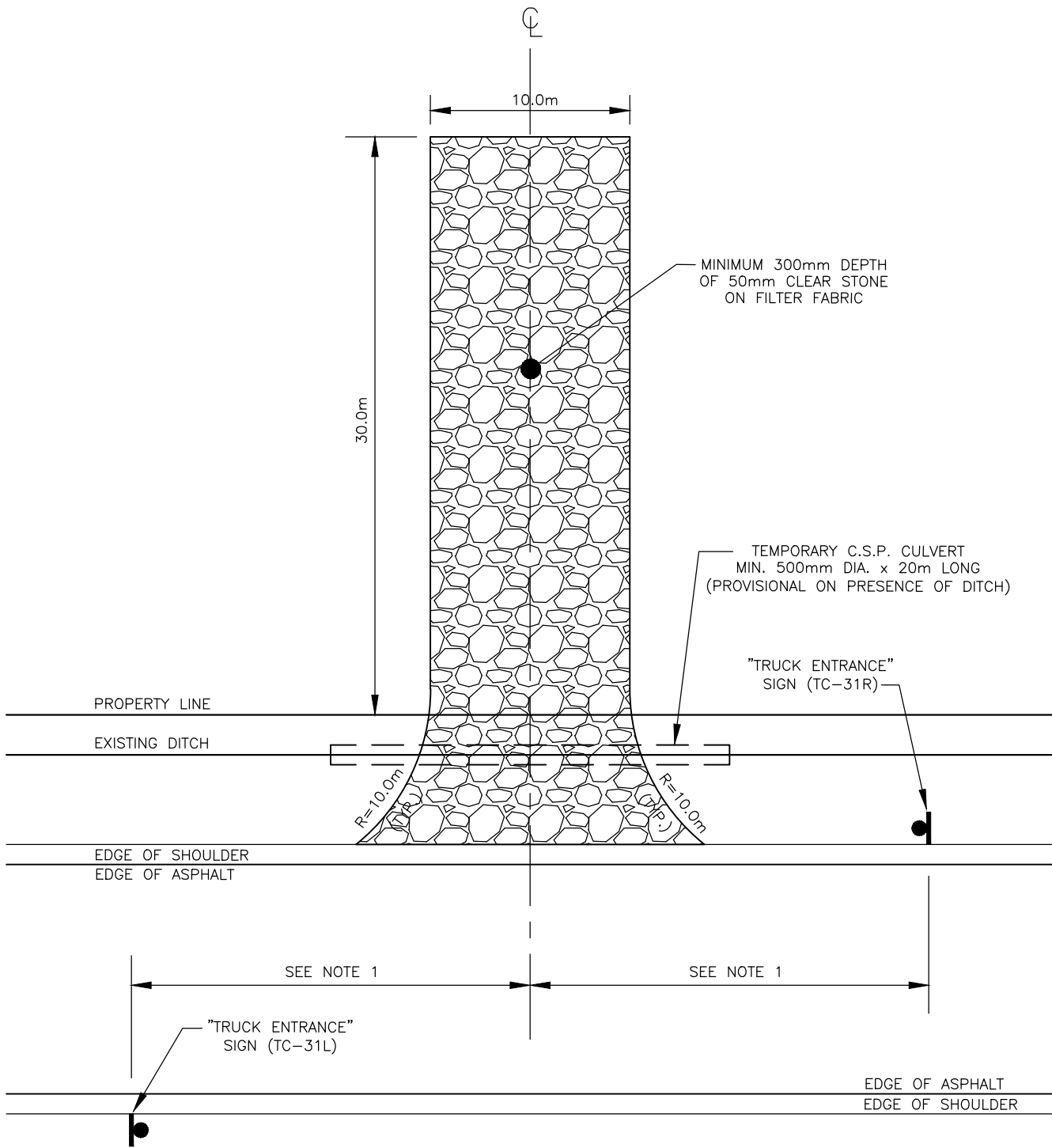

NOTES

1. TEMPORARY "TRUCK ENTRANCE" SIGNS (TC-31) SHALL BE INSTALLED ON THE SHOULDER, 150m IN ADVANCE OF THE CONSTRUCTION ACCESS. THE APPLICANT WILL BE RESPONSIBLE FOR THE COST OF OBTAINING, ERECTING AND MAINTAINING THESE SIGNS.
2. THE TEMPORARY CONSTRUCTION ACCESS SHALL BE REMOVED FROM THE ROAD ALLOWANCE WHEN ITS USE IS FINISHED AND ALL DISTURBED AREAS SHALL BE RESTORED TO ORIGINAL OR BETTER CONDITION.



TEMPORARY CONSTRUCTION ACCESS DETAIL



| NO. | REVISIONS | DATE | APR'D |
|-----|-----------|------|-------|
| | | | |
| | | | |
| | | | |

| |
|-----------------|
| SCALE: N.T.S. |
| DATE: NOV. 2021 |
| ERIN SD. |
| 120 |

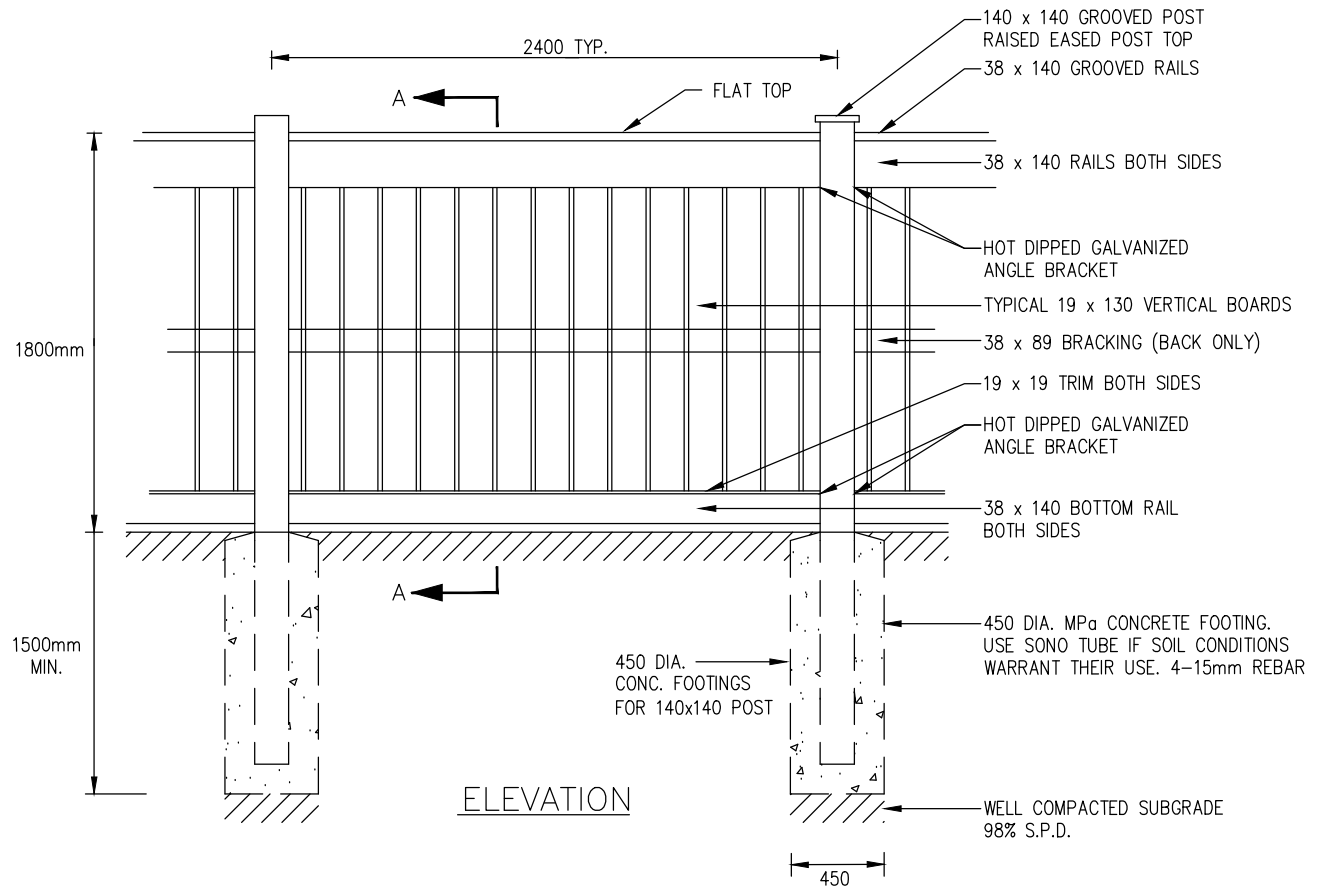
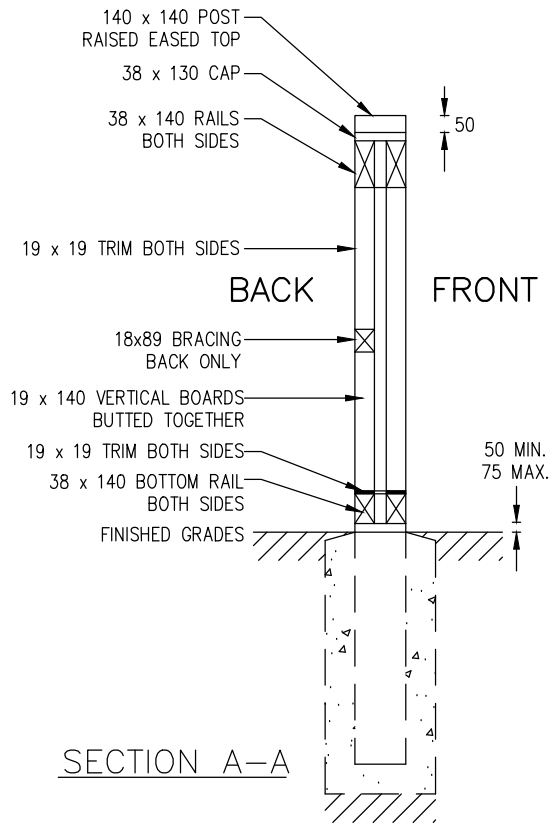

NOTE:

1. ALL WOOD TO BE NO.1 CONSTRUCTION GRADE WESTERN RED CEDAR OR NORTHERN WHITE SELECTED FOR GOOD APPEARANCE AND FREE OF WAVE, BARK AND PITCH POCKETS. POSTS TO BE SELECTED STRUCTURAL.
2. ALL WOOD COMPONENTS SHALL BE TREATED WITH 2 COATS OF SIKKENS STAIN OR APPROVED EQUAL. COLOUR TO BE GRAY UNLESS OTHERWISE APPROVED BY THE TOWN.
3. USE HOT DIPPED GALVANIZED ARDOX NAILS AND HARDWARE WHERE REQUIRED.
4. COMPLETE FENCE AND ALL APPURTENANCES INCLUDING FOOTINGS, TO BE LOCATED ENTIRELY ON PRIVATE PROPERTY.

ADDITION NOTES:

1. FOR SINGLE / SEMI-DETACHED LOTS, 0.15m SETBACK REQUIRED FROM PROPERTY LINE ABUTTING MUNICIPAL BOULEVARD.
2. FENCE SHOULD RETURN TO HOUSE AT REAR FACE.
3. 1.0m OPENING AT HOUSE FOR REAR YARD ACCESS.
4. SOIL BENEATH AND WITHIN 2m RADIUS OF ANY FOOTING, SHALL BE CERTIFIED 95% STANDARD PROCTOR DENSITY PRIOR TO CONSTRUCTION.



PRIVACY FENCE DETAIL

SCALE: N.T.S.

DATE: NOV. 2021

**ERIN SD.
121**

| NO. | REVISIONS | DATE | APR'D |
|-----|-----------|------|-------|
| | | | |
| | | | |
| | | | |
| | | | |

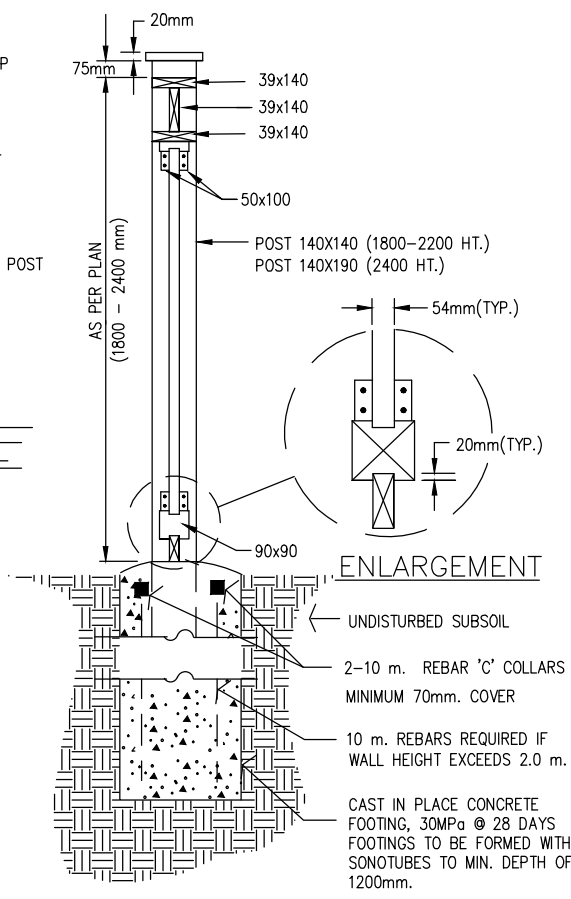
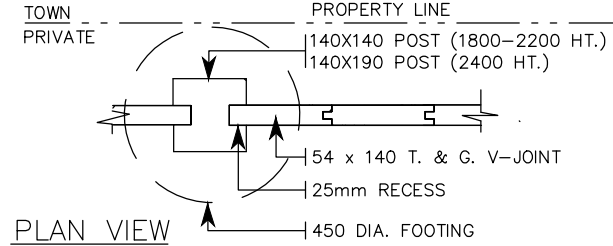
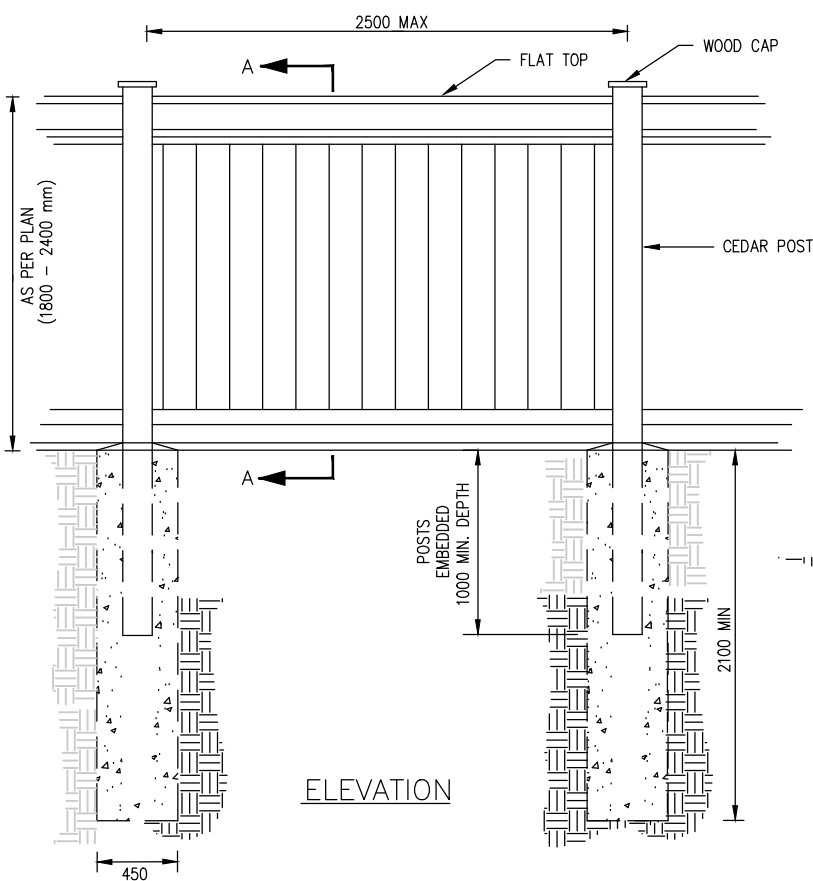

SECTION A-A

WARRANTY
 The fence shall be guaranteed for until assumption as follows: 5 mm/m on plumb of posts and level of infill members. Gaps between infill members shall not exceed 6 mm (1/4"). Infill members shall be tight and free of rattling.

NOTES:

MATERIALS

WOOD (GENERAL SPECIFICATIONS)

All wood to be select tight knot western red cedar or northern white. All torn grain and surface stain shall be eliminated by sanding or planing. Members with heavy knots and/or sap stain shall be well distributed throughout the installation.

INFILL - Tongue & Groove select (sound) tight knot NLGA pattern 18-(200) modified 54 mm 2 1/8" (dressed both sides) with bevelled edges on both sides.

HORIZONTAL MEMBERS

- Shall be 39 x 140 mm dressed to pattern, the grade to be NLGA 204B or better select tight knot grade.

POSTS - Shall be 140 x 140 mm (for 1800 to 2200 mm ht) or 140 x 190 mm (for 2400 mm ht) dressed to pattern, the grade to be NLGA 131B#1 structural post and timber.

FASTENERS - Including ardox nails, bolts, nuts and washers, shall be hot-dip galvanized steel.

CONCRETE - Shall be 30 MPA at 28 days minimum.

DIMENSIONS - All noted are in millimeters.

EXECUTION

SOIL - Beneath and within 2 m. radius of any footing, shall be certified 95% standard proctor density prior to construction.

POSTS - Shall be plumb within 5 mm/m. above grade.

INFILL - Members shall be tight fitted to eliminate all gaps and rattling.

STEP FENCE - On slopes minimum 50 mm and 150 mm maximum at each post.

DOUBLE POST - All direction changes greater than 20°.

NAILING

All nails galv. ardox and 75 mm (3") unless noted otherwise. All nails to be evenly spaced and set not less than 25 mm from edge of any member.

Rails : 3 nails to post at each end, 3 nails thru bottom front rail to vertical members and 3 nails to skirt board in staggered pattern.

Skirt Rail : 2 nails to post at each end.

Facia Board : 2 nails (50mm - 2") each end to vertical members and 5 nails in staggered pattern along board.

Vertical Members : 2 nails (88 mm - 3 1/2") top and bottom to rails and 6 nails 50 mm (2") staggered pattern thru 19 mm boards to 39 mm boards for panel option 'B'.

Coping : 2 nails thru edges to post at each end and 6 nails thru top to vertical members.



MINIMUM ACOUSTIC FENCE DETAIL

SCALE: N.T.S.

DATE: NOV. 2021

**ERIN SD.
122**

| NO. | REVISIONS | DATE | APR'D |
|-----|-----------|------|-------|
| | | | |
| | | | |
| | | | |
| | | | |

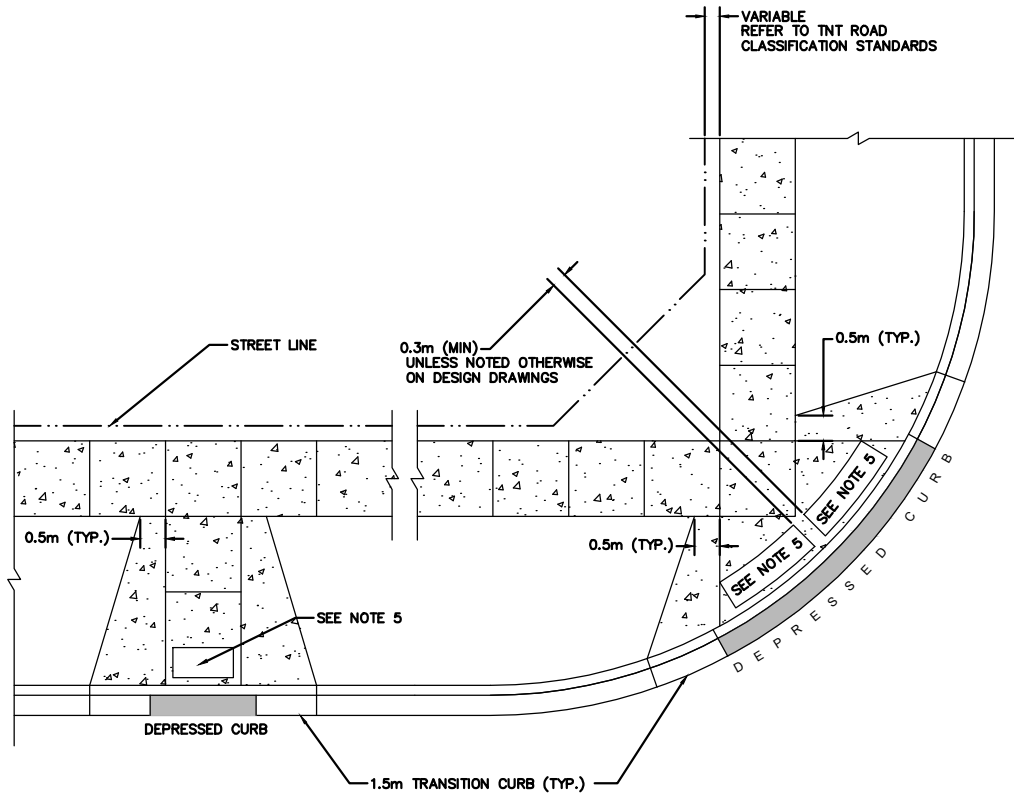

NOTES:

1. CURB RAMP WIDTH SHOULD MATCH SIDEWALK WIDTH, AND BE A MINIMUM OF 1.5m WIDE.
2. FOR CURB RAMP SLOPE OF 2% AND 5%, MAXIMUM 8%.
3. ALL DIMENSIONS ARE IN MILLIMETERS UNLESS OTHERWISE NOTED.
4. DEPRESSED CURB HEIGHT – FOR PEDESTRIAN CURB RAMPS 0 TO 6 mm.
5. CORNER OF TACTILE WALKING SURFACE INDICATOR (TWSI) TO MATCH OFFSET FROM THE BACK OF CURB RADIUS. ALL TWSI'S SHALL HAVE 6mm WIDE AND 6mm DEEP DRAIN GROOVES AT CORNERS BETWEEN TWSI AND CURB. PANEL JOINTS MAY BE ADAPTED FOR USE IF TOUCHING. TOP OF TWSI SHALL BE ALIGNED AND LEVEL WITH ADJACENT SURFACE.
6. TWSI COMPONENTS TO BE PER OPSD 310.039 AND OPSS 351.
7. MINIMUM THICKNESS OF RAMP SHALL BE 200mm. MINIMUM THICKNESS OF SIDEWALK AND FLARED SIDES ADJACENT TO RAMP SHALL BE 150mm.



PEDESTRIAN CURB RAMP WITH BOULEVARD



| NO. | REVISIONS | DATE | APR'D |
|-----|-----------|------|-------|
| | | | |
| | | | |
| | | | |

SCALE: N.T.S.
 DATE: NOV. 2021
ERIN SD.
123

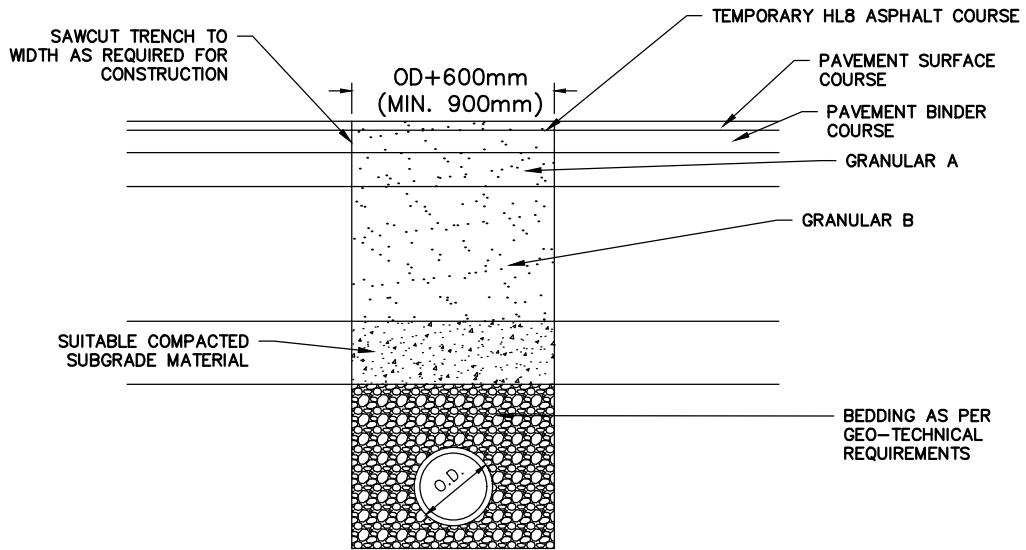

TEMPORARY RESTORATION

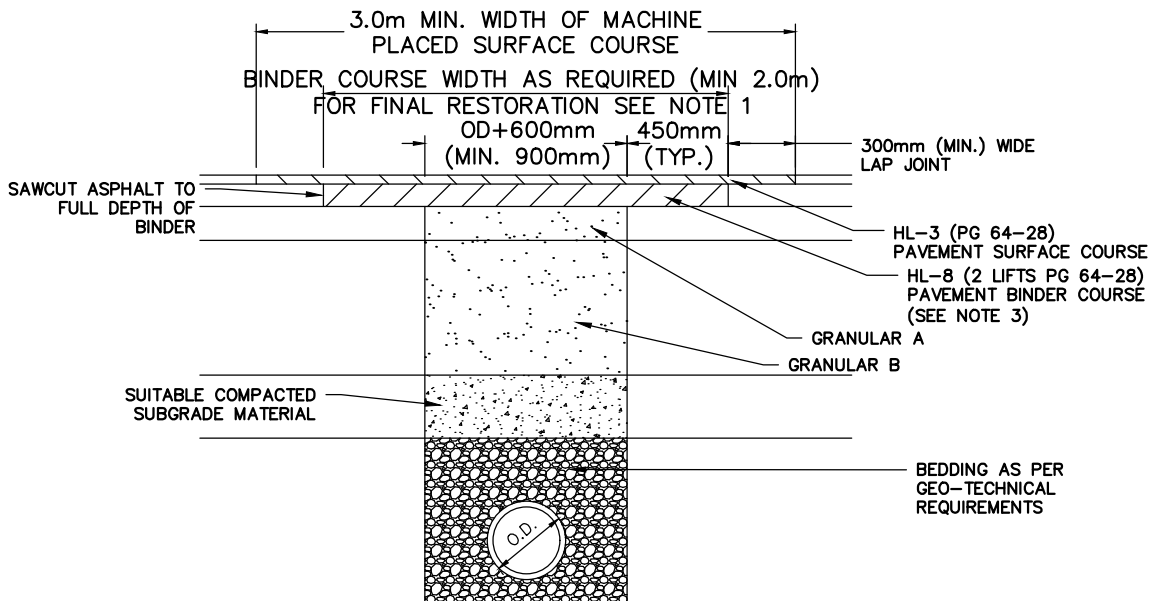

FINAL RESTORATION

NOTES:

1. WHERE EDGE OF TRENCH IS WITHIN 1.0 METRE OF EDGE OF PAVEMENT, FULL DEPTH PAVEMENT REMOVAL SHALL BE REQUIRED
2. REMOVE AND REPLACE EXISTING ASPHALT FULL DEPTH TO 450 mm BEYOND LONGITUDINAL ENDS OF TRENCH
3. DEPTH OF GRANULAR AND ASPHALT MATERIALS SHALL BE AS SPECIFIED ON CONTRACT DRAWINGS OR AS SPECIFIED BY THE ROAD AUTHORITY



**TRENCH RESTORATION
DETAIL**



| NO. | REVISIONS | DATE | APR'D |
|-----|-----------|------|-------|
| | | | |
| | | | |
| | | | |

SCALE: N.T.S.
DATE: NOV. 2021
ERIN SD.
124

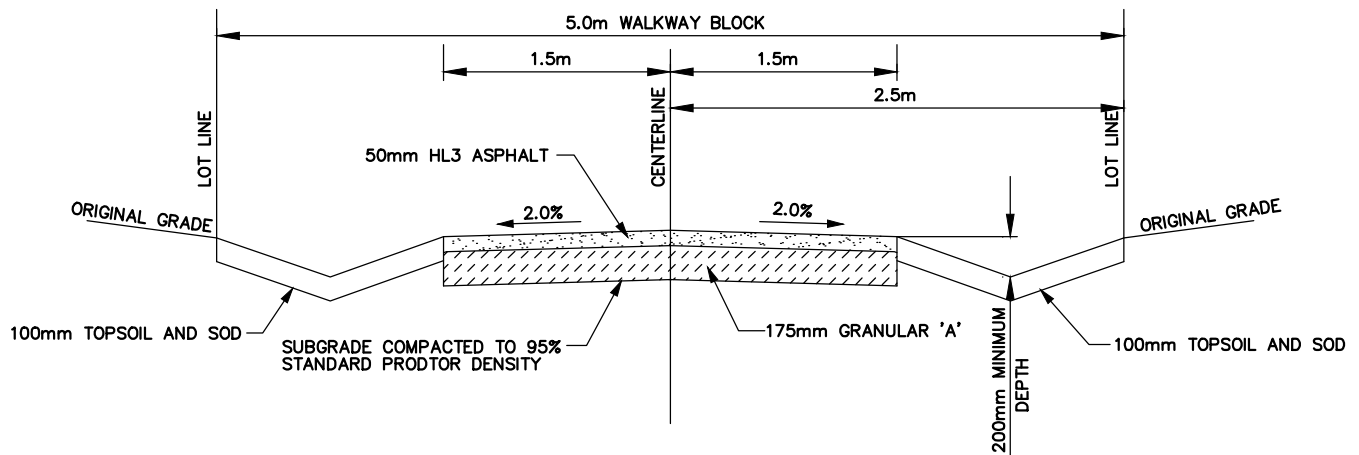

NOTES:

1. ALL GRANULAR MATERIALS TO BE COMPACTED TO 100% STANDARD PROCTOR DENSITY.
2. PROPOSED LONGITUDIAL GRADE OF WALKWAY TO BE IDENTIFIED ON ENGINEERING DRAWINGS.
MINIMUM LONGITUDINAL GRADE TO BE 1.5%.



MULTI USE TRAIL



METRIC
ALL DIMENSIONS ARE
IN METRES UNLESS
OTHERWISE SHOWN

| NO. | REVISIONS | DATE | APR'D |
|-----|-----------|------|-------|
| | | | |
| | | | |
| | | | |

SCALE: N.T.S.
DATE: NOV. 2021
ERIN SD.
125

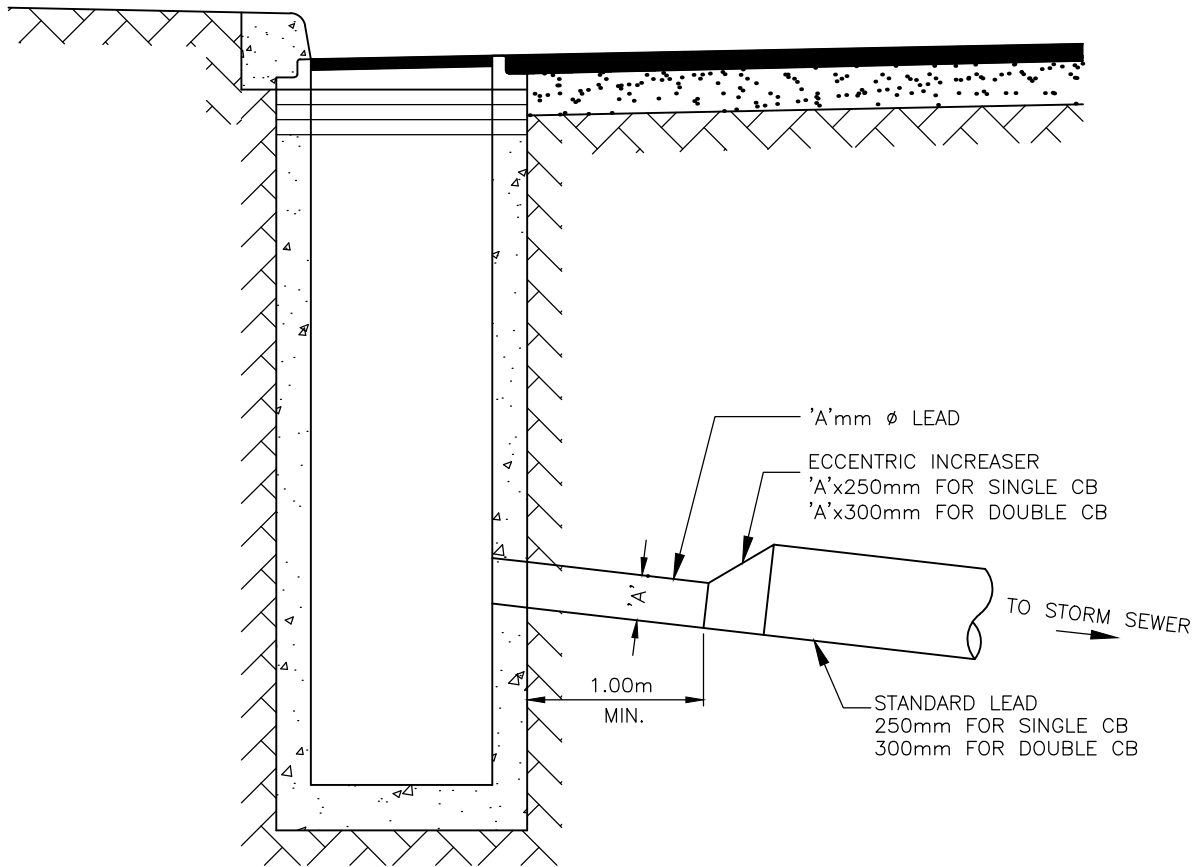

REDUCED CATCHBASIN LEAD DETAIL

LEAD CAPACITIES AT 1.50m TYPICAL DEPTH TO CENTROID;
DISCHARGE COEFFICIENT = 0.64

- 100mm ø – 0.027 m³/s
- 125mm ø – 0.043 m³/s
- 150mm ø – 0.061 m³/s



**REDUCED CATCHBASIN
LEAD DETAIL**



| NO. | REVISIONS | DATE | APR'D |
|-----|-----------|------|-------|
| | | | |
| | | | |
| | | | |

| |
|-------------------------|
| SCALE: N.T.S. |
| DATE: NOV. 2021 |
| ERIN SD. 201 |

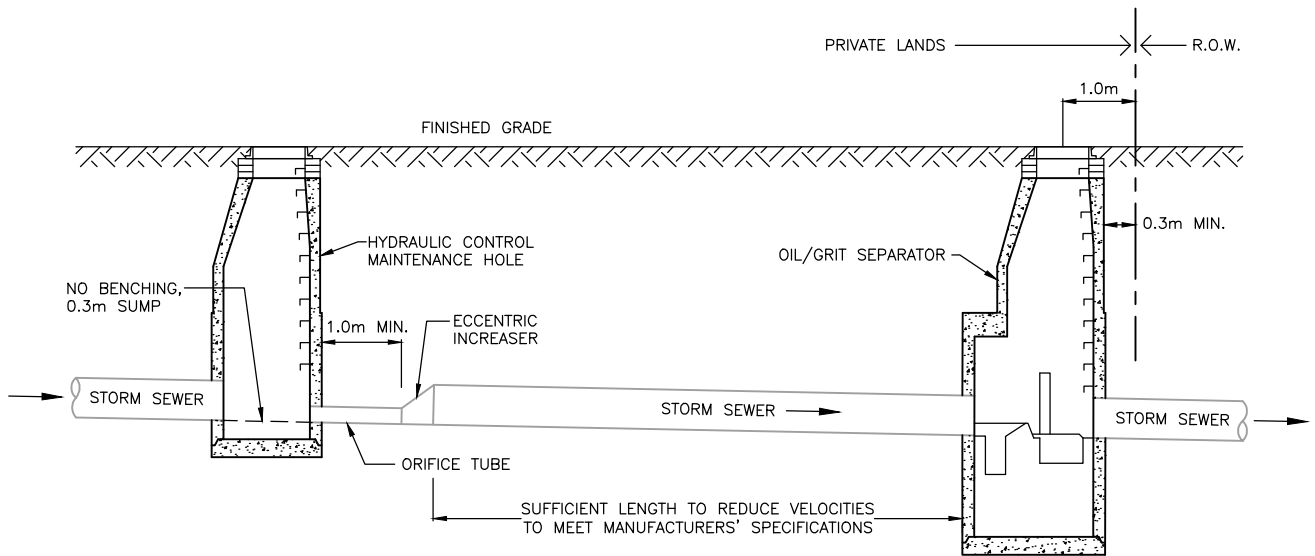

WHERE QUALITY CONTROL REQUIRED

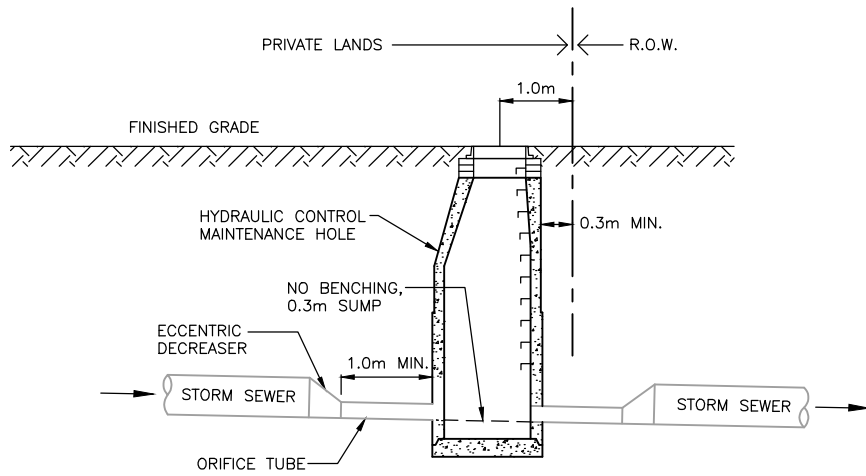

WHERE QUALITY CONTROL NOT REQUIRED



**ON-SITE STORMWATER
MANAGEMENT CONTROL DETAIL**



METRIC
ALL DIMENSIONS ARE
IN METRES UNLESS
OTHERWISE SHOWN

| NO. | REVISIONS | DATE | APR'D |
|-----|-----------|------|-------|
| | | | |
| | | | |
| | | | |

SCALE: N.T.S.
DATE: NOV. 2021

**ERIN SD.
202**

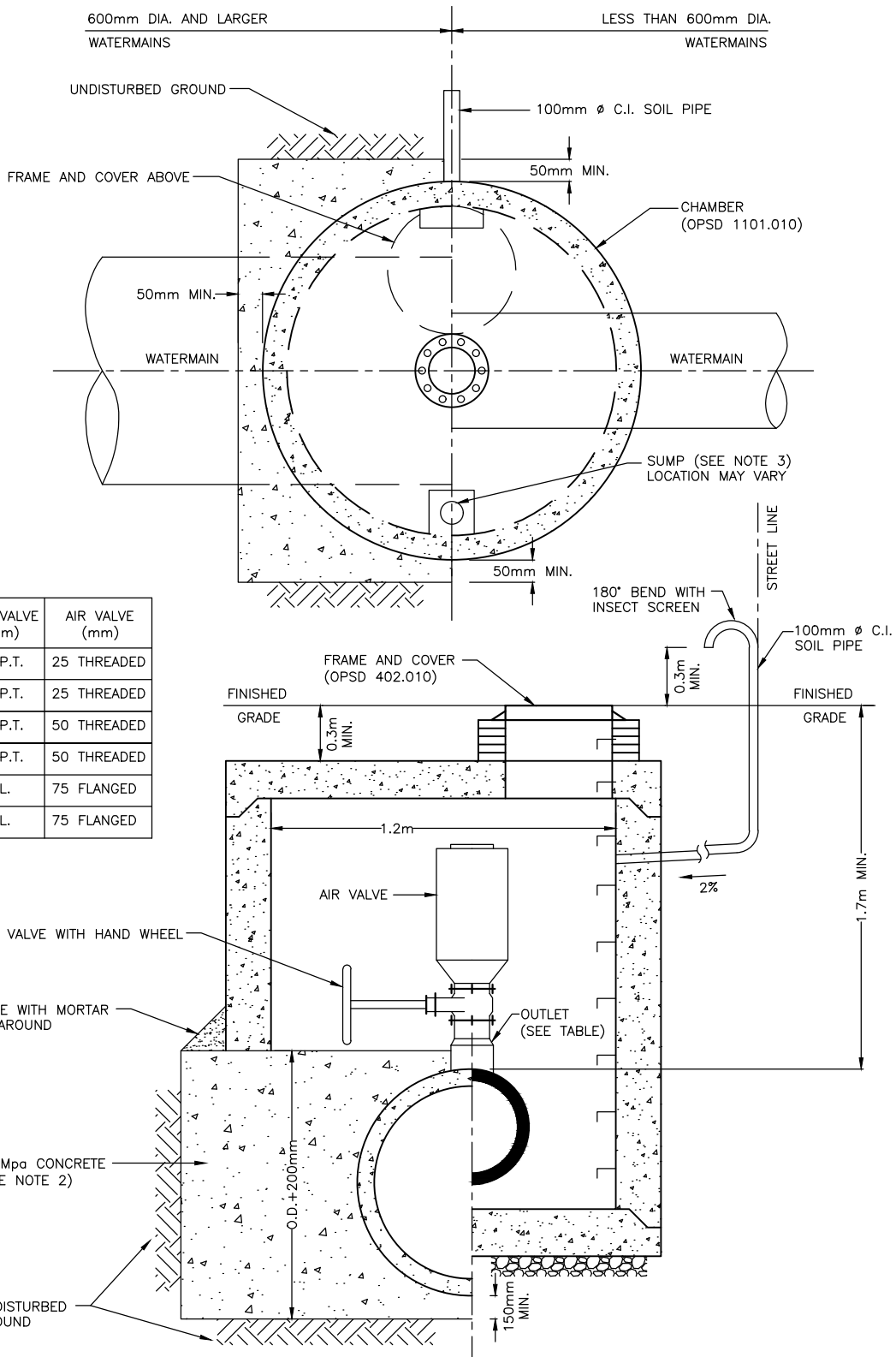

- NOTES:**
- FOR 25mm AND 50mm AIR VALVE MUST USE I.P.T. THREADED OUTLET WITH BRASS NIPPLES AS REQUIRED.
 - CONCRETE REQUIRED ON WATERMANS 600mm DIA. AND LARGER.
 - SUMP AND 100mmØ DRAIN CONNECTED TO STORM SEWER OR OTHER SUITABLE OUTLET WHEREVER POSSIBLE.



AIR VALVE IN CHAMBER DETAIL



| NO. | REVISIONS | DATE | APR'D |
|-----|-----------|------|-------|
| | | | |
| | | | |
| | | | |

| |
|-----------------|
| SCALE: N.T.S. |
| DATE: NOV. 2021 |
| ERIN SD. |
| 301 |

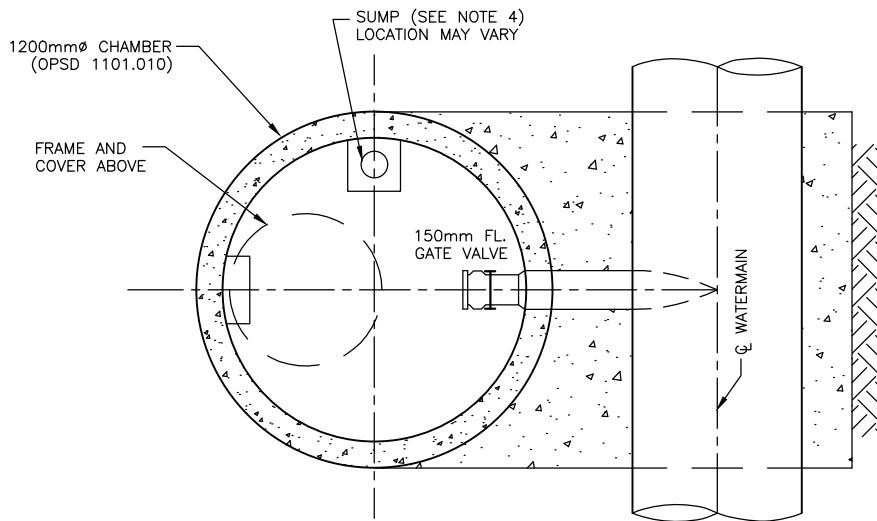

TOP VIEW
(CONC. PIPE ONLY)

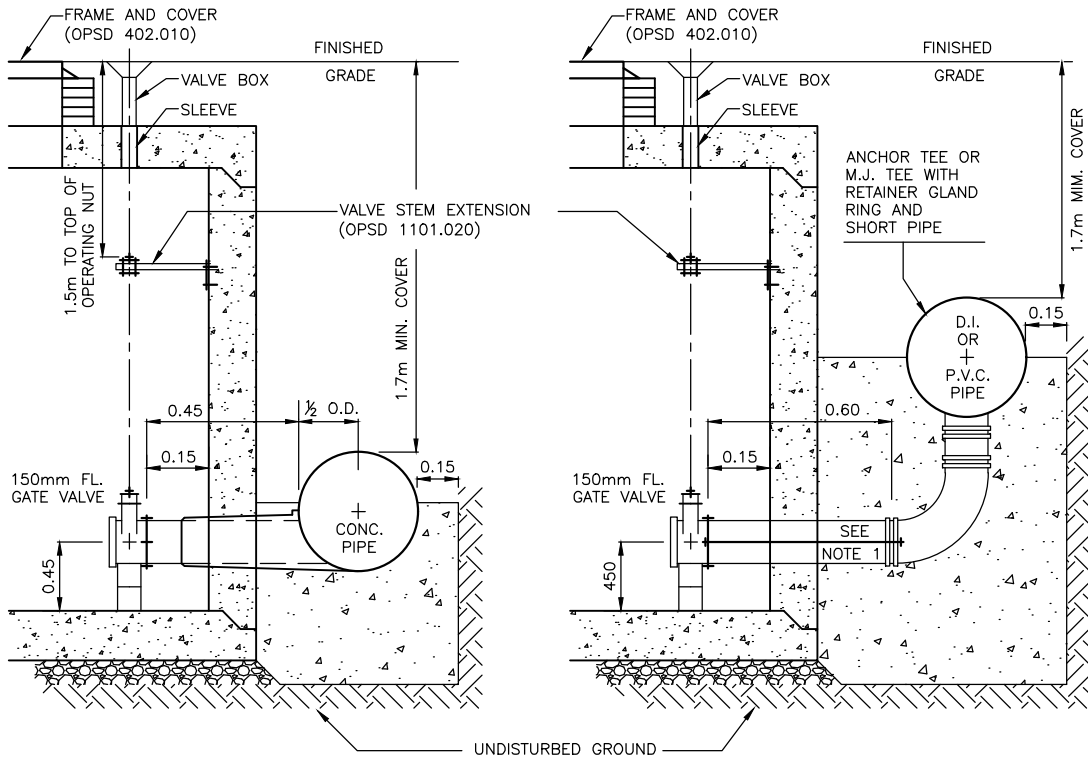

NOTES:

1. ON D.I. AND P.V.C. PIPE, VALVE TO BE TIED BACK TO WM. WITH S.S. TIE RODS. RETAINER GLAND RINGS OR UNI-FLANGE 1300C.
2. IF CHAMBER REQUIRES A SAFETY PLATFORM, CHAMBER TO BE 1500mm DIA. (SEE OPSD 1101.010 FOR DETAILS)
3. PROVIDE 200mm DIA. DRAIN VALVE FOR MAIN 750mm DIA. AND LARGER.
4. SUMP AND 100mmØ DRAIN CONNECTED TO STORM SEWER OR OTHER SUITABLE OUTLET WHEREVER POSSIBLE.

| NO. | REVISIONS | DATE | APR'D |
|-----|-----------|------|-------|
| | | | |
| | | | |
| | | | |

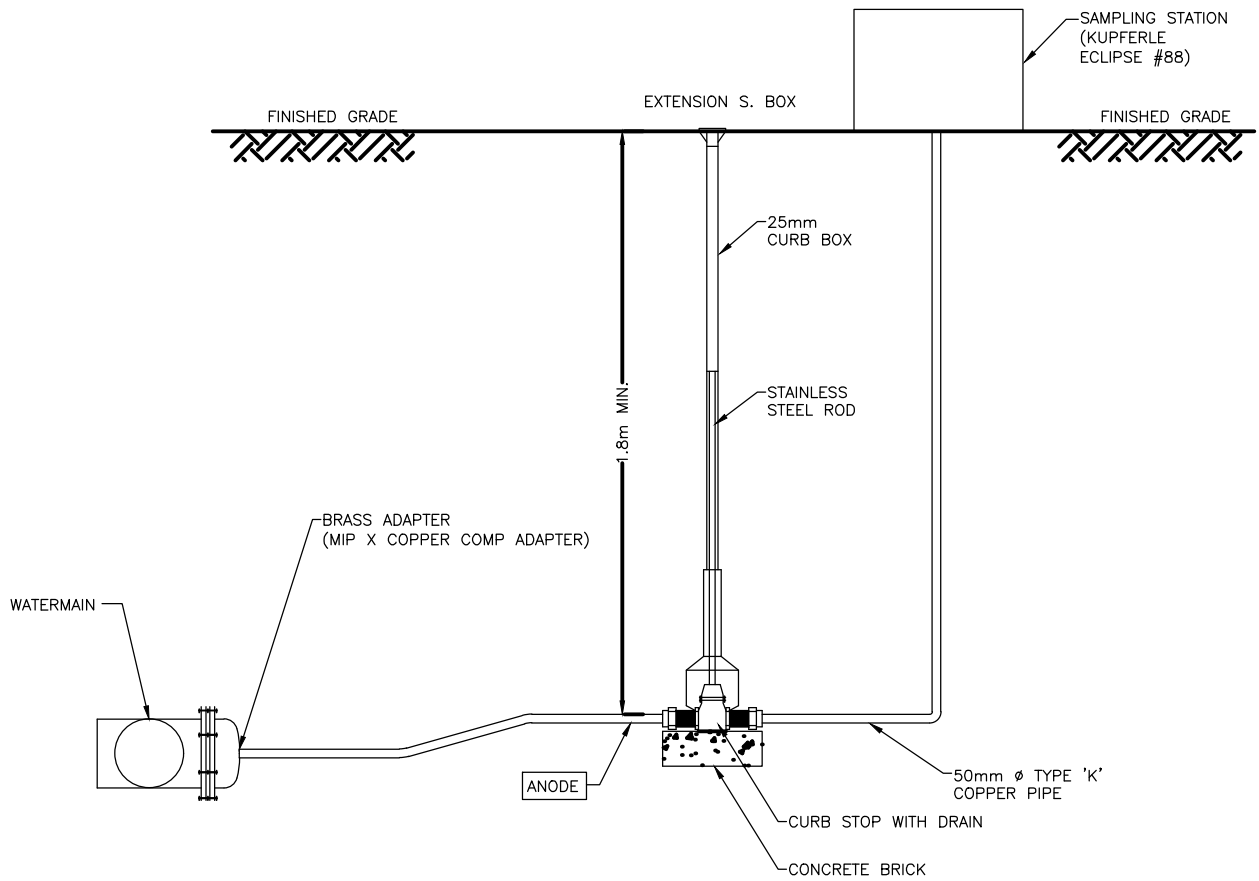

ELEVATION

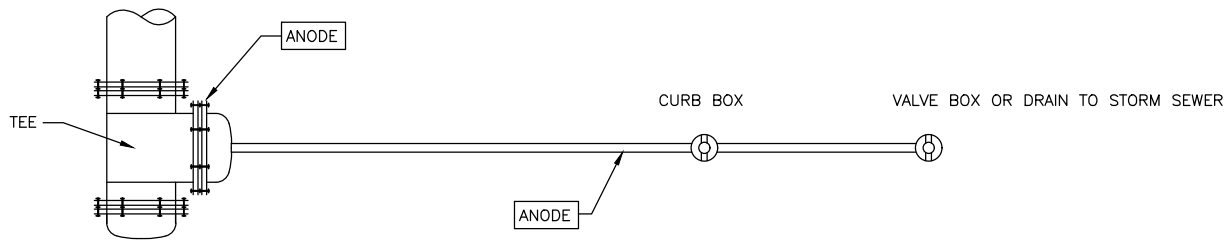

PLAN

NOTES:

1. REFER TO WATERWORKS MATERIAL SPECIFICATIONS.
2. ANY JUNCTIONS IN SERVICE TO BE MADE WITH APPROVED COUPLINGS.
3. CURB STOP WITH DRAIN TO BE USED.
4. USE 25mm CURB STOP FOR WATERMAIN DIA. UP TO 200mm. FOR WATERMAIN GREATER THAN 200mm DIA., USE 50mm CURB STOP.



**SAMPLING STATION
CHAMBER STANDARD**



METRIC
ALL DIMENSIONS ARE
IN METRES UNLESS
OTHERWISE SHOWN

| NO. | REVISIONS | DATE | APR'D |
|-----|-----------|------|-------|
| | | | |
| | | | |
| | | | |

SCALE: N.T.S.
DATE: NOV. 2021
ERIN SD.
303

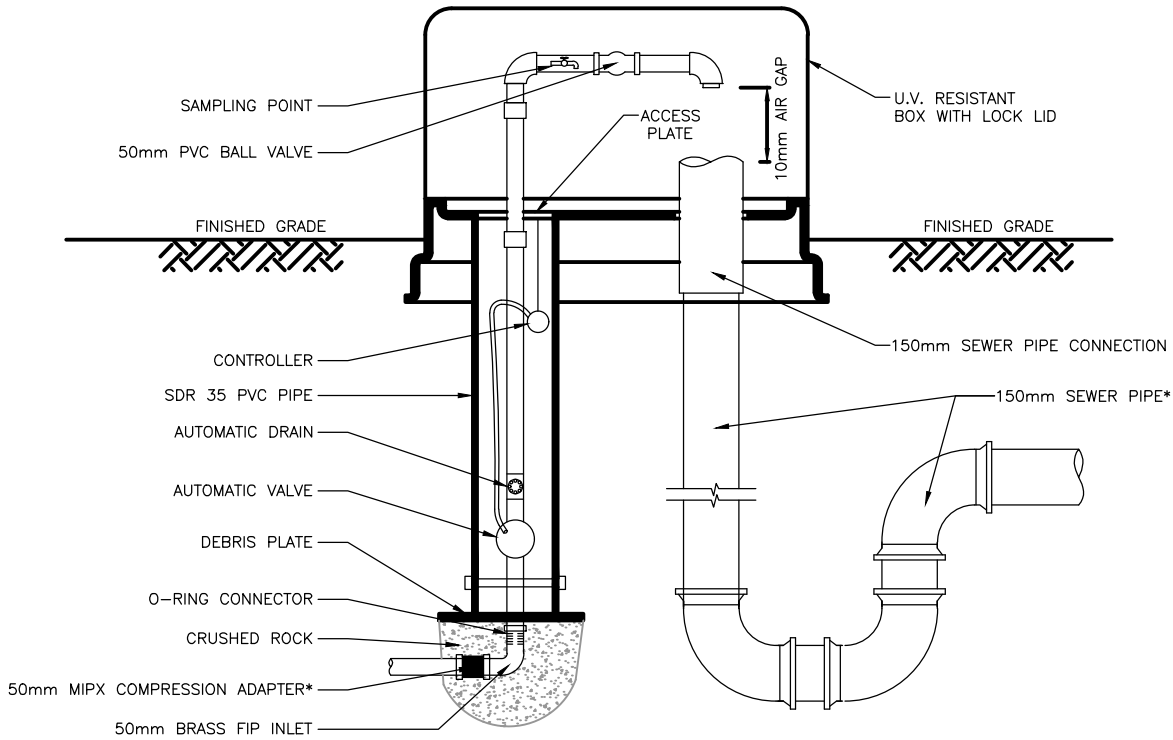

AUTOMATIC FLUSHING DEVICE SHALL HAVE A 50mm BRASS FIP INLET, LEADING VERTICALLY INTO A 50mm SOLENOID VALVE. AUTOMATIC SOLENOID VALVE SHALL HAVE AN INTERNAL, SELF-CLEANING DEBRIS SCREEN, AND HAVE A 220 PSI RATING EACH UNIT SHALL BE FURNISHED WITH A STAND-ALONE VALVE CONTROLLER. VALVE CONTROLLER WILL NOT REQUIRE A SECOND HAND-HELD DEVICE FOR PROGRAMMING. CONTROLLER MUST HAVE A MINIMUM OF 9 POSSIBLE FLUSHING CYCLES PER DAY, SHALL BE SUBMERSIBLE TO 3.65m, OPERATE WITH A 9 VOLT BATTERY AND HAVE RESIN-SEALED ELECTRICAL COMPONENTS, SOLENOID SHALL HAVE NO LOOSE PARTS WHEN REMOVED FROM VALVE. EACH UNIT SHALL HAVE A DOUBLE-VALVE, ALL BRASS SAMPLING POINT. REMOVAL OF 50mm SOLENOID VALVE SHALL BE POSSIBLE VIA AN O-RING CONNECTOR LOCATED UNDER THE VALVE AFTER REMOVAL OF STAINLESS STEEL ACCESS PLATE. VALVE ASSEMBLY SHALL BE HOUSED IN A PVC ENCLOSURE AND EACH UNIT SHALL BE SELF-DRAINING, NON FREEZING, ALL ABOVE-GROUND COMPONENTS SHALL BE CONTAINED WITHIN A UV-RESISTANT LOCING COVER, AS MANUFACTURED BY KUPFERLE FOUNDRY COMPANY.

TOWN OF
ERIN

FLUSHING STATION
(KUPFERLE ECLIPSE MODEL 9800)



METRIC
ALL DIMENSIONS ARE
IN METRES UNLESS
OTHERWISE SHOWN

| NO. | REVISIONS | DATE | APR'D |
|-----|-----------|------|-------|
| | | | |
| | | | |
| | | | |

SCALE: N.T.S.
DATE: NOV. 2021

ERIN SD.
304

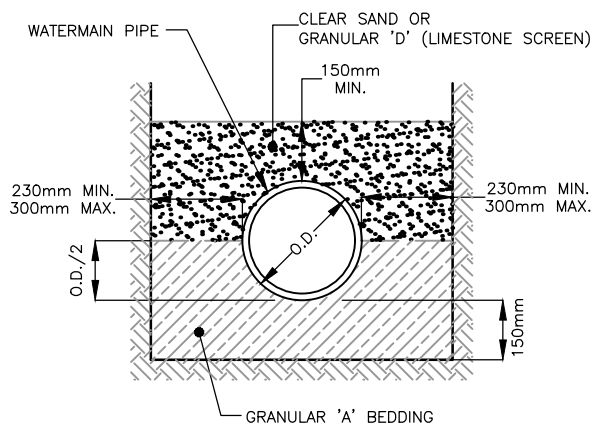

**PREFERRED METHOD
NORMAL SOIL CONDITIONS**

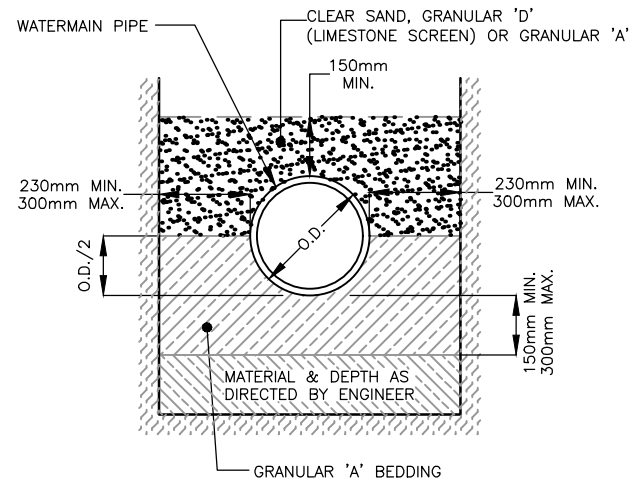

POOR SOIL CONDITIONS

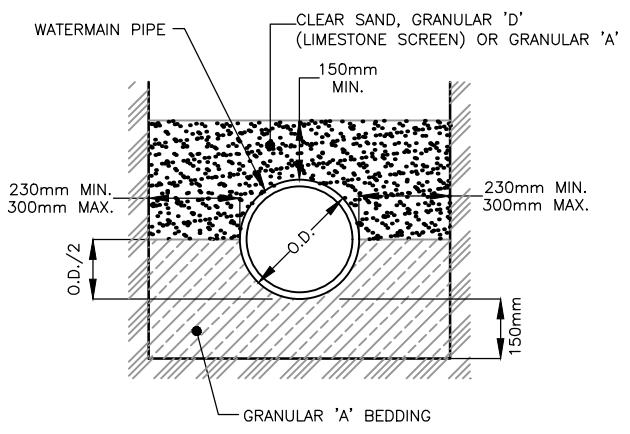

ROCK TRENCHES

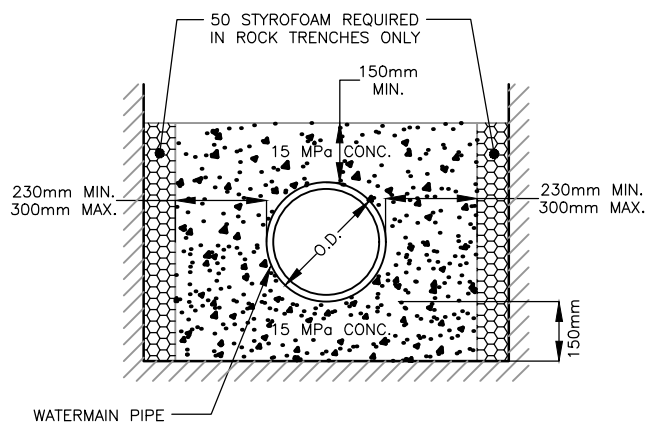

CONCRETE ENCASED WHERE SPECIFIED

NOTES:

1. BEDDING MATERIAL TO BE FULLY EXTENDED AND COMPACTED AGAINST TRENCH WALL AND BE PLACED IN 150mm LAYERS AND COMPACTED TO 100% STANDARD PROCTOR DENSITY.
2. CLASS "F1" BEDDING TO BE USED AND ALL JOINTS RESTRAINED IN FILL AREAS, SILTY CLAY, WET TRENCH. ENGINEER MAY VARY PIPE FOUNDATION TO SUIT.
3. BACKFILL ABOVE BEDDING AS APPROVED BY GEOTECHNICAL ENGINEER.
4. GRANULAR MATERIAL AS PER OPSS SPECIFICATION.



WATERMAIN BEDDING DETAIL



| NO. | REVISIONS | DATE | APR'D |
|-----|-----------|------|-------|
| | | | |
| | | | |
| | | | |

SCALE: N.T.S.
 DATE: NOV. 2021
**ERIN SD.
 305**

MODIFIED 600x600mm
PRECAST CONCRETE
HANDHOLE PER OPSD
2112.040

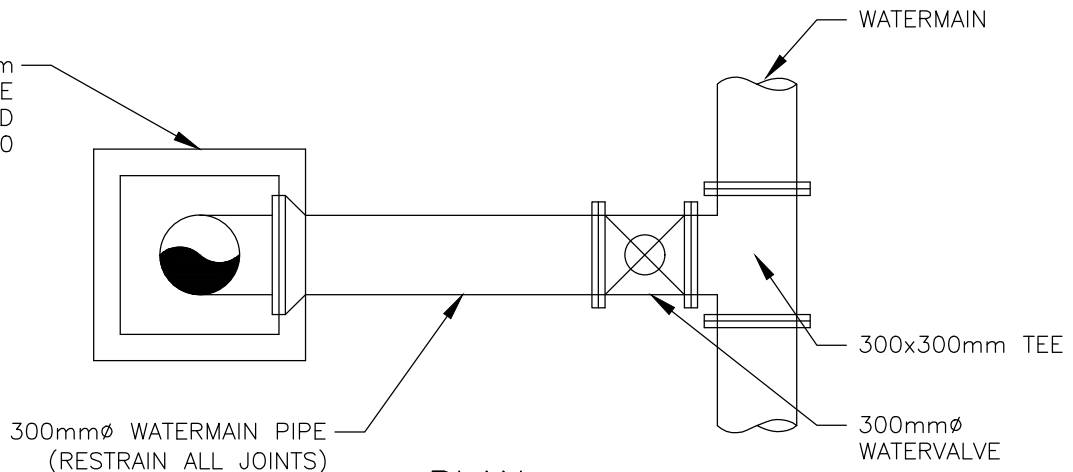

PLAN

FRAME AND COVER
AS PER OPSD 401.010

25mm ϕ IPT THREADED
NIPPLE c/w 25mm ϕ
THREADED GATE VALVE
(JENKINS MODEL 810 OR
EQUAL) BLIND FLANGE
FOR PRESSURE RELEASE

MODIFIED 600x600mm
PRE-CAST CONCRETE
HANDHOLE PER OPSD 2112.040

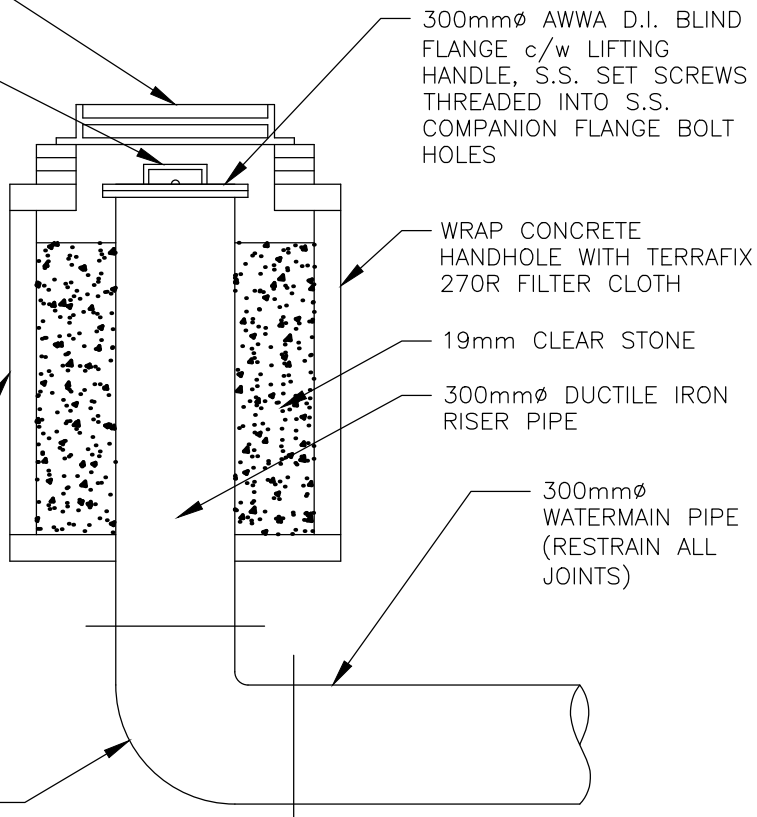

PROFILE



**WATERMAIN SWABBING
PORT DETAIL**



METRIC
ALL DIMENSIONS ARE
IN METRES UNLESS
OTHERWISE SHOWN

| NO. | REVISIONS | DATE | APR'D |
|-----|-----------|------|-------|
| | | | |
| | | | |
| | | | |

SCALE: N.T.S.
DATE: NOV. 2021

**ERIN SD.
308**

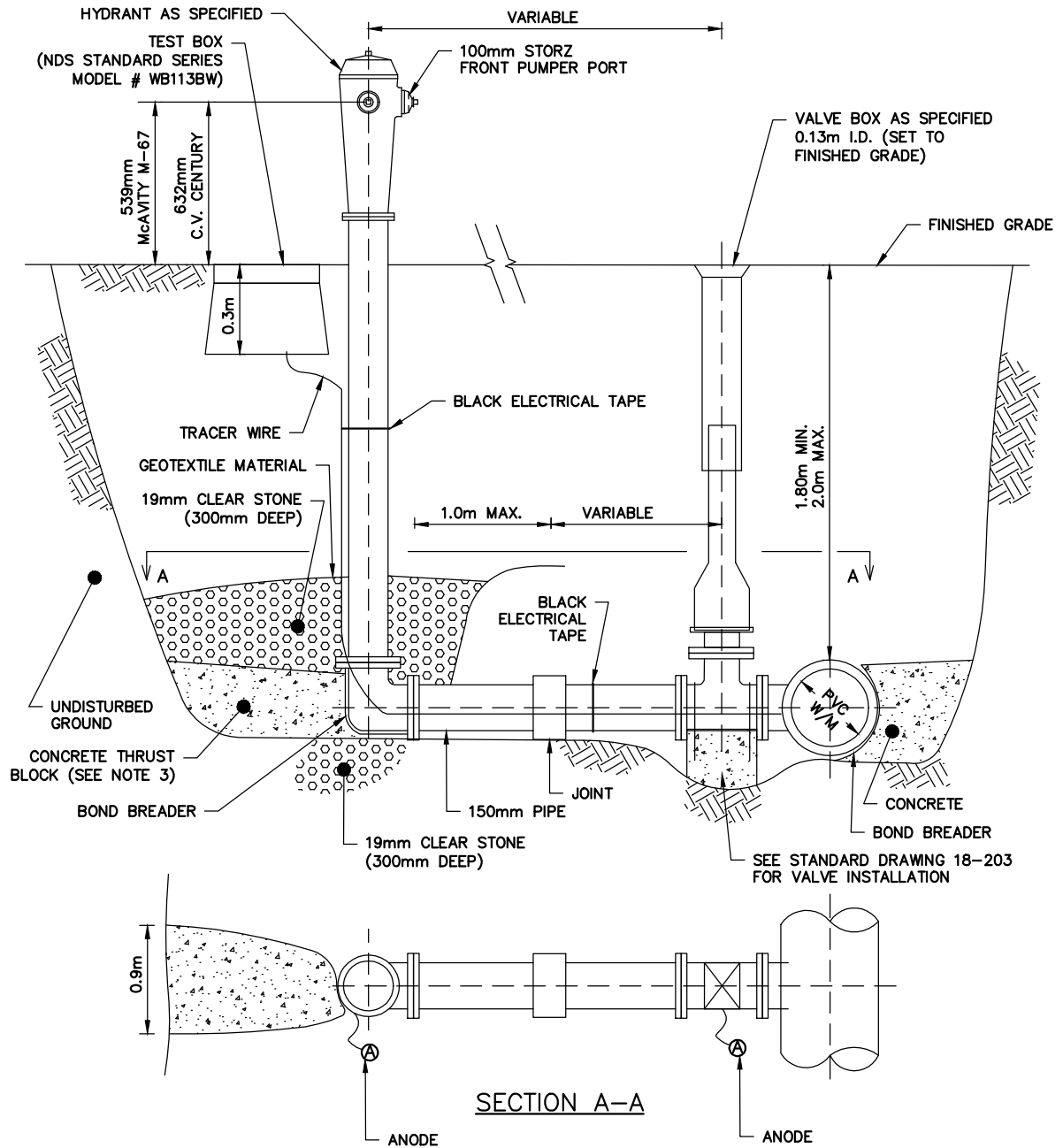

NOTES:

1. MIN. STRENGTH OF CONCRETE 20MPa UNLESS SPECIFIED OTHERWISE.
2. ALL CONCRETE BLOCK TO BE POURED AGAINST UNDISTURBED GROUND.
3. IN ADDITION TO CONCRETE THRUST BLOCK, MECHANICAL RESTRAINTS SHALL BE USED AT ALL JOINTS ALONG THE HYDRANT LEAD.
4. ALL HYDRANT LEADS MUST HAVE A JOINT BETWEEN MAIN AND HYDRANT BOOT. THE FIRST JOINT MUST BE NO FURTHER THAN 1.0m FROM THE HYDRANT BOOT.
5. HYDRANT RISER SECTIONS SHALL BE GENERALLY AVOIDED. IF HYDRANT RISERS ARE REQUIRED, THEY SHALL BE INSTALLED AT THE BOOT OF THE CANADA VALVE(CENTURY) AND THE TOP OF THE McAVITY M-67. HYDRANT RISER SHALL IN NO CASE EXCEED 0.9m IN HEIGHT.
6. PROVIDE 300mm OF CLEAR STONE BELOW BOOT.

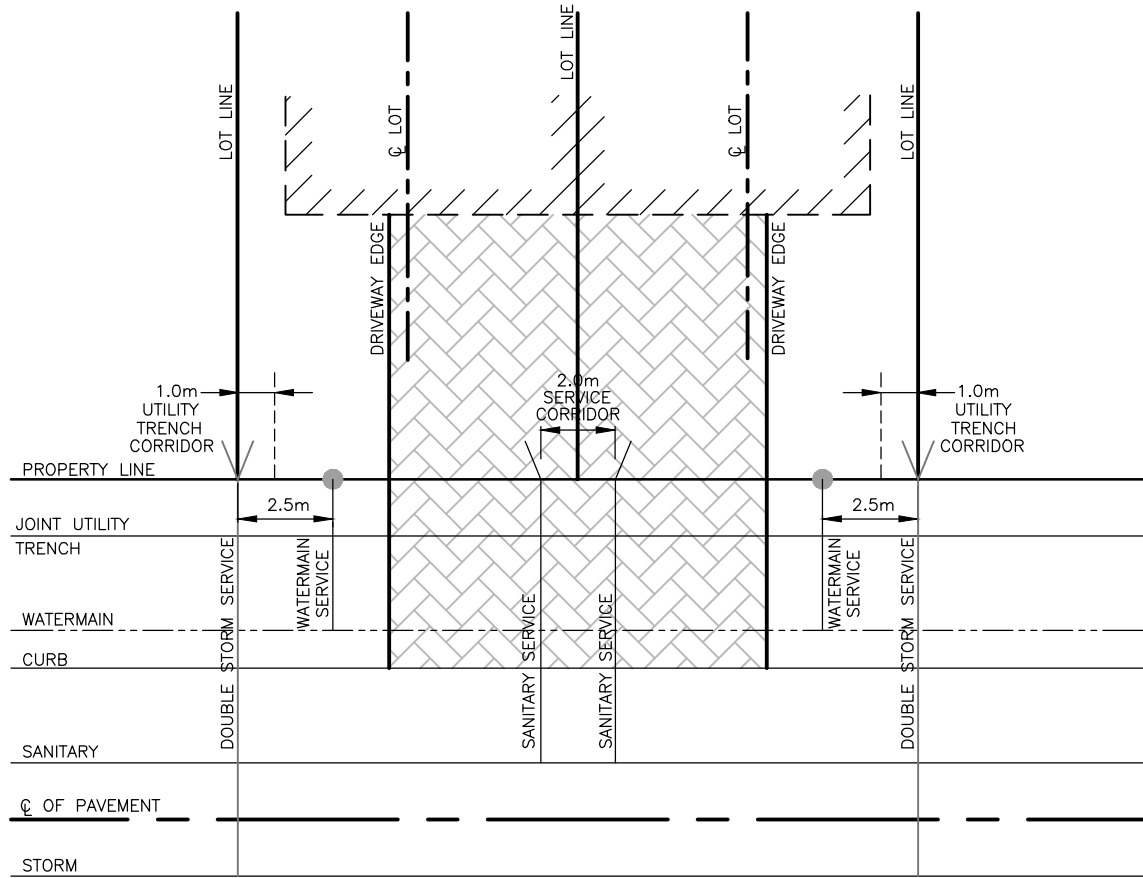

NOTES:

1. CLEAN OUT REQUIRED IF SEWER CONNECTION LENGTH IS GREATER THAN 30.0m.



**TYPICAL SEMI-DETACHED UNIT
SERVICE ARRANGEMENT**



METRIC
ALL DIMENSIONS ARE
IN METRES UNLESS
OTHERWISE SHOWN

| NO. | REVISIONS | DATE | APR'D |
|-----|-----------|------|-------|
| | | | |
| | | | |
| | | | |

SCALE: N.T.S.
DATE: NOV. 2021
ERIN SD.
402

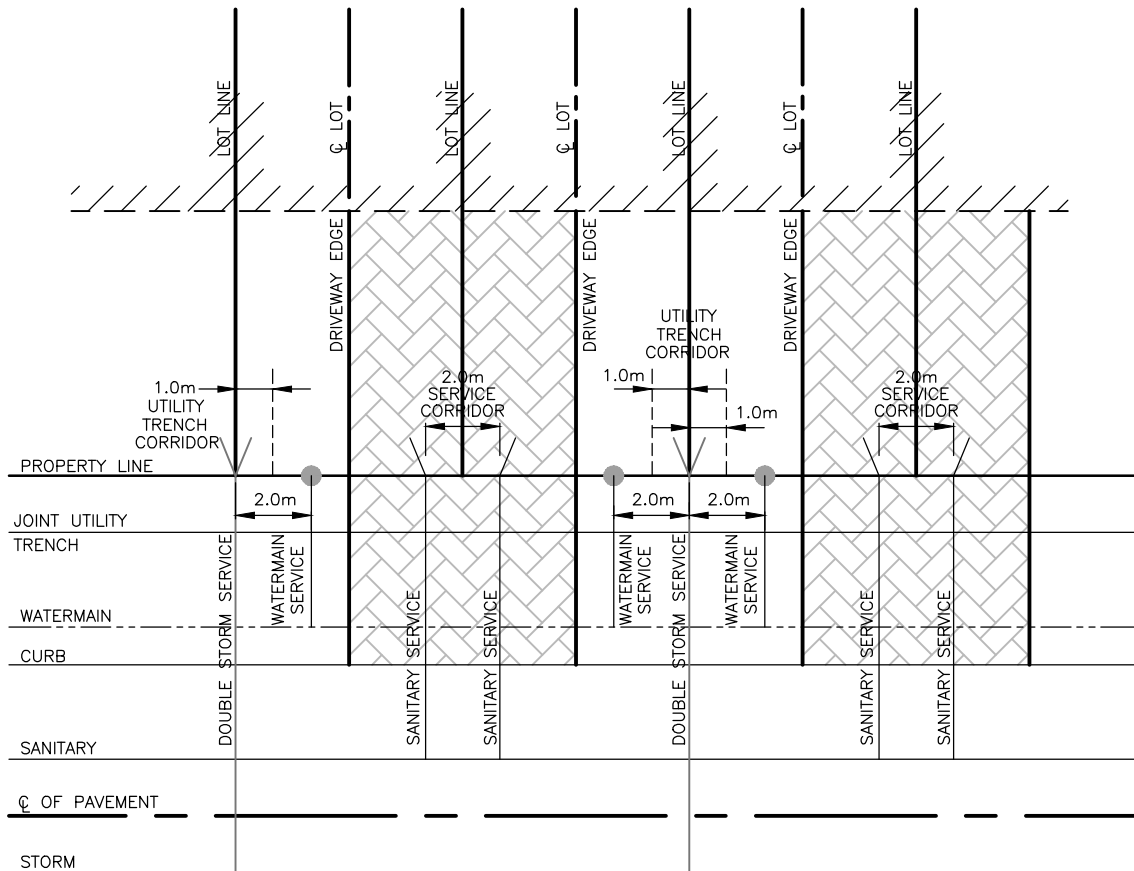

NOTES:

1. CLEAN OUT REQUIRED IF SEWER CONNECTION LENGTH IS GREATER THAN 30.0m.



**TYPICAL TOWNHOUSE UNIT
SERVICE ARRANGEMENT**



METRIC
ALL DIMENSIONS ARE
IN METRES UNLESS
OTHERWISE SHOWN

| NO. | REVISIONS | DATE | APR'D |
|-----|-----------|------|-------|
| | | | |
| | | | |
| | | | |

SCALE: N.T.S.
DATE: NOV. 2021
ERIN SD.
403

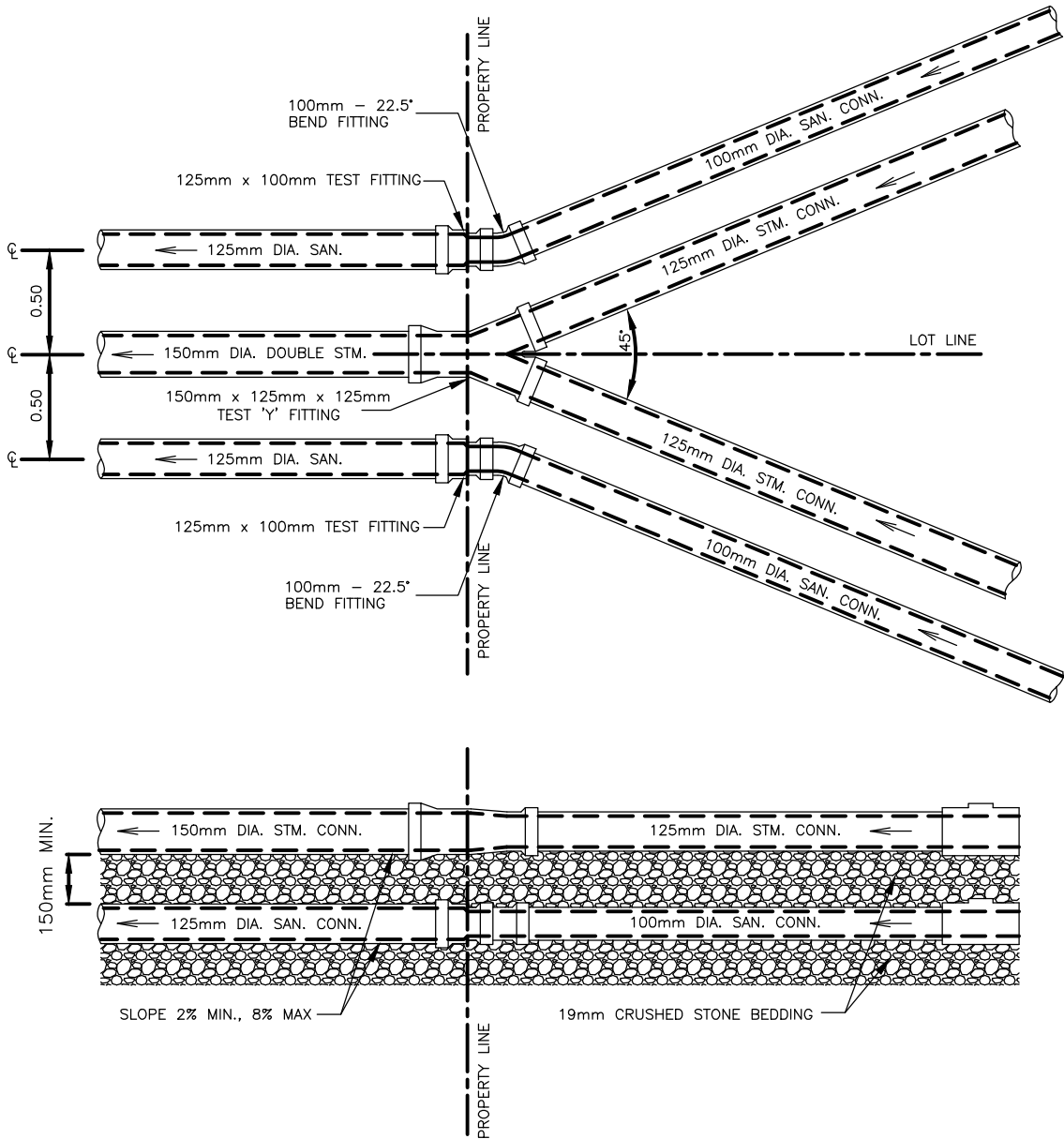

NOTE:

1. SERVICE CORRIDOR TRENCH WIDTH TO BE 2.0m.
2. MIN. COVER TO STM. SERVICE TO BE 2.5m, MIN. COVER TO SAN. SERVICE TO BE 2.7m.
3. GRANULAR 'A' BEDDING TO BE USED.
4. 100mm DIA. TEST FITTING TO BE MARKED "SAN"; 125mm DIA. TEST FITTING TO BE MARKED "STM".
5. SANITARY CONNECTION PIPE TO BE GREEN IN COLOUR; STORM CONNECTION PIPE TO BE WHITE IN COLOUR.
6. SANITARY AND STORM CONNECTIONS MUST BE SECURELY PLUGGED AT PROPERTY LINE WITH AN APPROVED PLUG.



**DOUBLE SERVICE CONNECTIONS
IN COMMON TRENCH**



METRIC
ALL DIMENSIONS ARE
IN METRES UNLESS
OTHERWISE SHOWN

| NO. | REVISIONS | DATE | APR'D |
|-----|-----------|------|-------|
| | | | |
| | | | |
| | | | |

SCALE: N.T.S.
DATE: NOV. 2021
ERIN SD.
404

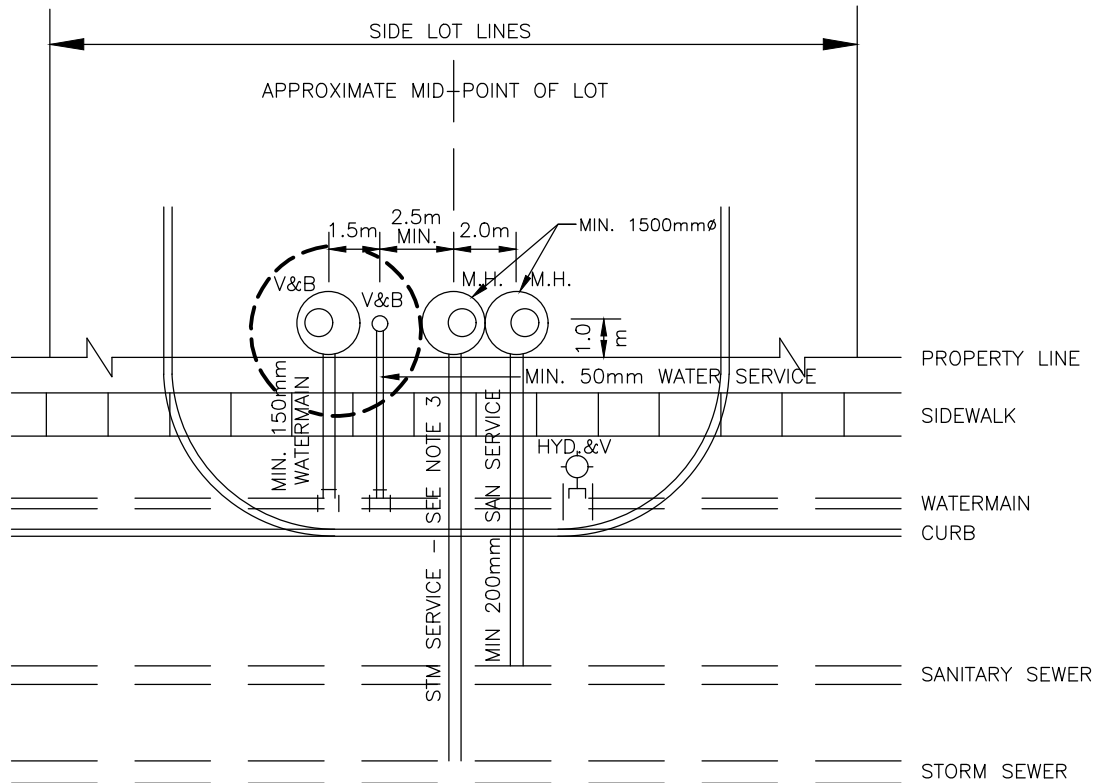

NOTES:

1. ABOVEGROUND UTILITIES TO BE LOCATED MINIMUM 1.0m FROM CURBS, SIDEWALK AND DRIVEWAYS.
2. MAINTENANCE HOLES FOR SERVICE CONNECTIONS TO BE LOCATED AT 1.0m OFF STREET LINE ON PRIVATE PROPERTY.
3. STORM SEWER CONNECTIONS SHALL BE SIZED BASED UPON STORM WATER MANAGEMENT REQUIREMENTS.
4. BOND BREAKER TO BE USED BETWEEN ALL WATERMAIN FITTINGS AND CONCRETE.
5. PROVIDE RESTRAINED MECHANICAL JOINTS OR SLIP-ON JOINTS WITH TIE RODS & CLAMPS FOR WATERMAIN, AS REQUIRED.



**INDUSTRIAL/COMMERCIAL/INSTITUTIONAL
SERVICE CONNECTIONS**

| NO. | REVISIONS | DATE | APR'D |
|-----|-----------|------|-------|
| | | | |
| | | | |
| | | | |
| | | | |

SCALE: N.T.S.

DATE: NOV. 2021

**ERIN SD.
405**

NOTES:

1. PIPE SHALL BE 125mm DIA. PVC.
MEETING CSA-B182.4-M90, RUBBER GASKET TYPE JOINTS.
2. MIN. SLOPE OF PIPE TO BE 1%.
3. JUNCTION OF SUMP DISCHARGE AND STORM SERVICE MUST BE ABOVE FINISHED GRADE AND IS NOT TO BE SEALED.
4. SUMP DISCHARGE PIPE TO BE CONNECTED TO THE SUMP PUMP AND FASTENED AS PER PART 7 OF THE ONTARIO BUILDING CODE.

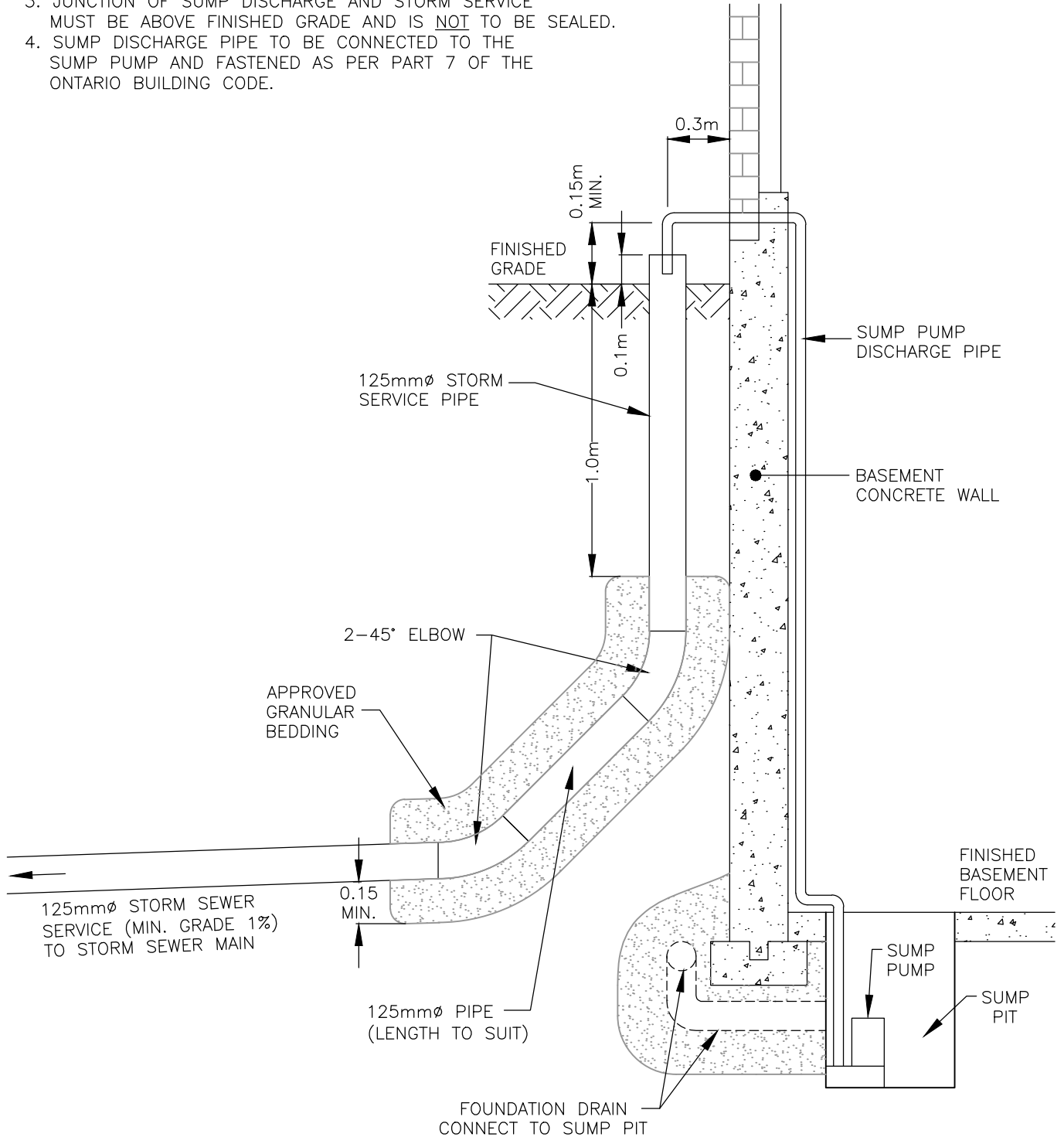

TYPICAL RESIDENTIAL STORM SEWER CONNECTION (125mm)



METRIC
ALL DIMENSIONS ARE
IN METRES UNLESS
OTHERWISE SHOWN

| NO. | REVISIONS | DATE | APR'D |
|-----|-----------|------|-------|
| | | | |
| | | | |
| | | | |

SCALE: N.T.S.
DATE: NOV. 2021
ERIN SD.
406

RADIO BOX
TO BE
INSTALLED
OVER SCAN
DISC (510R2)

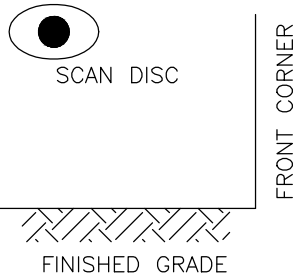

TOWN OF ERIN
APPROVED
WATER METER

INLET VALVE
CAMP/PAK JOINT
INLET VALVE WITH
PULL-OUT RESTRAINT
LOCKING SCREW
(NOTE 4)

STAINLESS
INSERT AND
TRACER
WIRE IF
POLY IS
USED

TO SCAN DISC
3 WIRE IN CONDUIT

SPLIT RING CLAMP
AND THREADED ROD
TO WALL PLATE IF
POLY IS USED

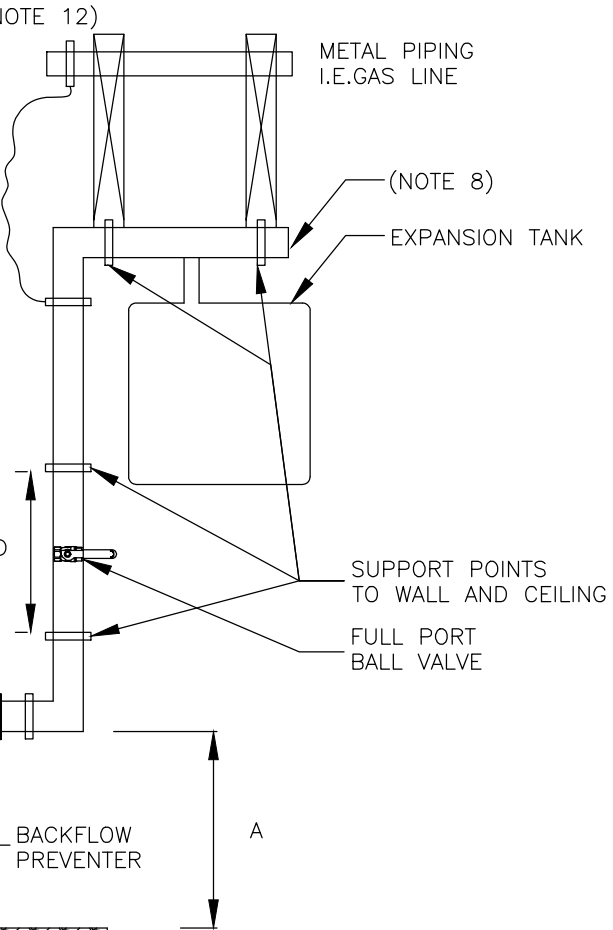

| PIPE IN | METER | PIPE OUT | CODE |
|---------|-------|----------|------|
| 19mm | 19mm | 19mm | R |
| 25mm | 19mm | 19mm | R/O |
| 25mm | 25mm | 25mm | L/C |

INSTALLATION NOTES - RESIDENTIAL

- SUPPLY LINE TO BE "K" TYPE COPPER, 25mm FOR NEW CONSTRUCTION OPTIONAL 19mm FOR EXISTING DEVELOPMENT OR POLY SERIES 160 OR BETTER.
- SUPPLY LINE MUST BE INSTALLED AS PER BUILDING CODE AND BUILDING DEPARTMENTS REQUIREMENTS PROTECTED FROM FROST AND BE FLUSHED, PRESSURE TESTED AND INSPECTED PRIOR TO BACKFILLING.
- LINE TO BE SET INTO BUILDING AT CLOSEST FRONT PORTION IN A HEATED AREA THAT IS ACCESSIBLE FOR READING, SERVICE WORK AND THAT IT ADHERES TO TOWN STANDARDS DRAWINGS.
- THE METER INLET VALVE SHALL BE A PACK JOINT OR CAMP/PAK INLET VALVE WITH PULL-OUT RESTRAINT LOCKING SCREW FULL PORT BALL TYPE WITH DIRECT SEAL CONNECTION TO THE METER INLET ONLY. THIS IS A MUNICIPAL TYPE VALVE, THE VALVE IS TO HAVE ONLY A GASKET CONNECTION TO THE METER, NO TREAD OR SEALANT COMPOUND.
- A BACKFLOW IS REQUIRED ON THE OUTLET SIDE OF THE METER USING ONLY A GASKET.
- AN ISOLATION VALVE IS ALSO DOWNSTREAM OF THE BACKFLOW PREVENTER FOR SERVICE WORK.
- A PRESSURE EXPANSION TANK AND/OR PRESSURE RELIEF VALVE IS REQUIRED TO PROTECT THE BUILDING FROM OVERPRESSURE DUE TO THERMAL EXPANSION. SHOULD AN EXPANSION TANK BE INSTALLED, THIS DEVICE MUST NOT BE INSTALLED ON THE METER RISER LINE TO THE CEILING, BUT BETWEEN CEILING AND COLD INLET LINE TO HOT WATER TANK. IT MUST BE WELL SUPPORTED TO CARRY THE WEIGHT AND LINE SHOCK OF THE WATER. THE INSTALLING PLUMBER WILL BE RESPONSIBLE TO DETERMINE THE SIZE & LOCATION OF THE EXPANSION TANK.
- SEE METER SERVICE DIAGRAM AND USE ONLY COPPER "U" TYPE DRIVE CLIPS AS OUTLINED. THE METER RISER MUST RUN FROM THE METER TO THE CEILING IN COPPER ONLY AS PER DRAWING. THE TYPE OF MATERIAL BEYOND THE CEILING SUPPORT IS TO BE APPROVED BY THE BUILDING DEPARTMENT.
- REMOTE READING SCAN DISK AND RADIO READ BOX ARE TO BE LOCATED ON THE FRONT WALL OR SIDEWALL NO FURTHER THAN 1 TO 1.5 METRES FROM FINISHED GRADE AND A MAXIMUM OF 1 METRE BACK FROM THE FRONT WALL. USING ONLY #8 RED ROBERTSON MACHINE SCREWS AND EXTERIOR GRADE WALL PLUGS.
- ALL WIRING TO BE RUN IN A CONDUIT FROM THE REMOTE READER TO THE METRE AREA USING PROPER CLIPS AND CONDUIT TO BE INSTALLED IN SUCH A WAY NOT TO BE DAMAGED FROM FINISHING IN THE AREA. ANY EXPOSED WIRE FROM THE CONDUIT TO THE METRE REGISTER ONLY CABLE TIES AND/OR "U" TYPE STAPLES TO BE USED.
- 3 CONDUCTOR 22 GAUGE WIRE ONLY WILL BE ACCEPTED.
- WHERE THE WATER SUPPLY LINE IS USED FOR ELECTRICAL SYSTEM GROUND, THE APPROPRIATE GROUND CLAMP AND CABLE IS TO BE LOCATED AS CLOSE AS POSSIBLE TO THE ENTRY POINT OF THE WATER SUPPLY LINE INTO THE HOUSE AND BEFORE OR UPSTREAM OF THE WATER METER. WHERE GROUND RODS OR PLATES ARE USED FOR ELECTRICAL SYSTEM GROUND THE COPPER WATER SUPPLY LINE MUST BE BONDED TO INTERNAL METAL PIPING WITH APPROPRIATE SIZED COPPER WIRING AND CLAMP.
- ADHERE TO TOWNS STANDARDS DRAWING AND ANY QUESTIONS CALL PUBLIC WORKS PRIOR TO COMMENCING OR INTERPRETING ANY INFORMATION NOT UNDERSTOOD.
- CALL FOR INSPECTION AFTER WORK IS COMPLETED TO OBC REQUIREMENTS.

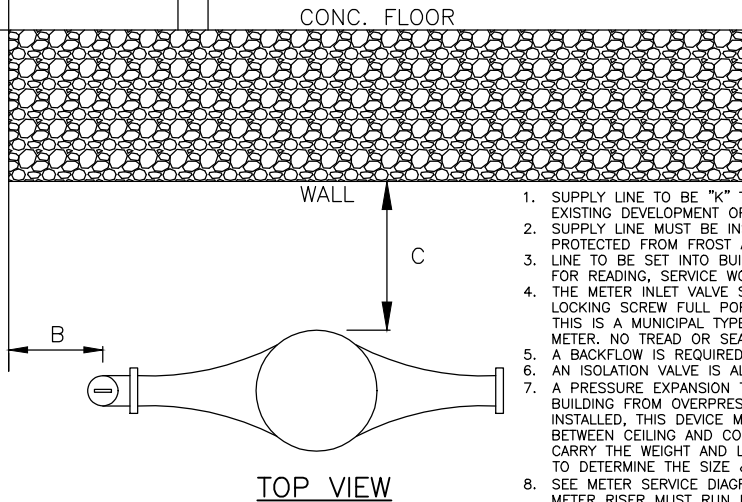

| MINIMUM CLEARANCE TABLE | |
|-------------------------|---|
| A | BOTTOM PLATE TO FLOOR 300mm-500mm MAX |
| B | INLET TO OBSTRUCTION 200mm |
| C | REAR BODY TO WALL 150mm |
| D | REGISTER TO OVER OBSTRUCTION (MIN. ONLY) 1m |
| E | SCAN DISC FINISH GRADE 1.0-1.5m |
| F | FRONT CORNER ON SIDE OR FRONT 0-1.0m MAX. |



TYPICAL RESIDENTIAL METER
INSTALLATION (25mm SUPPLY LINE)



| NO. | REVISIONS | DATE | APR'D |
|-----|-----------|------|-------|
| | | | |
| | | | |
| | | | |

SCALE: N.T.S.
DATE: NOV. 2021
ERIN SD.
407

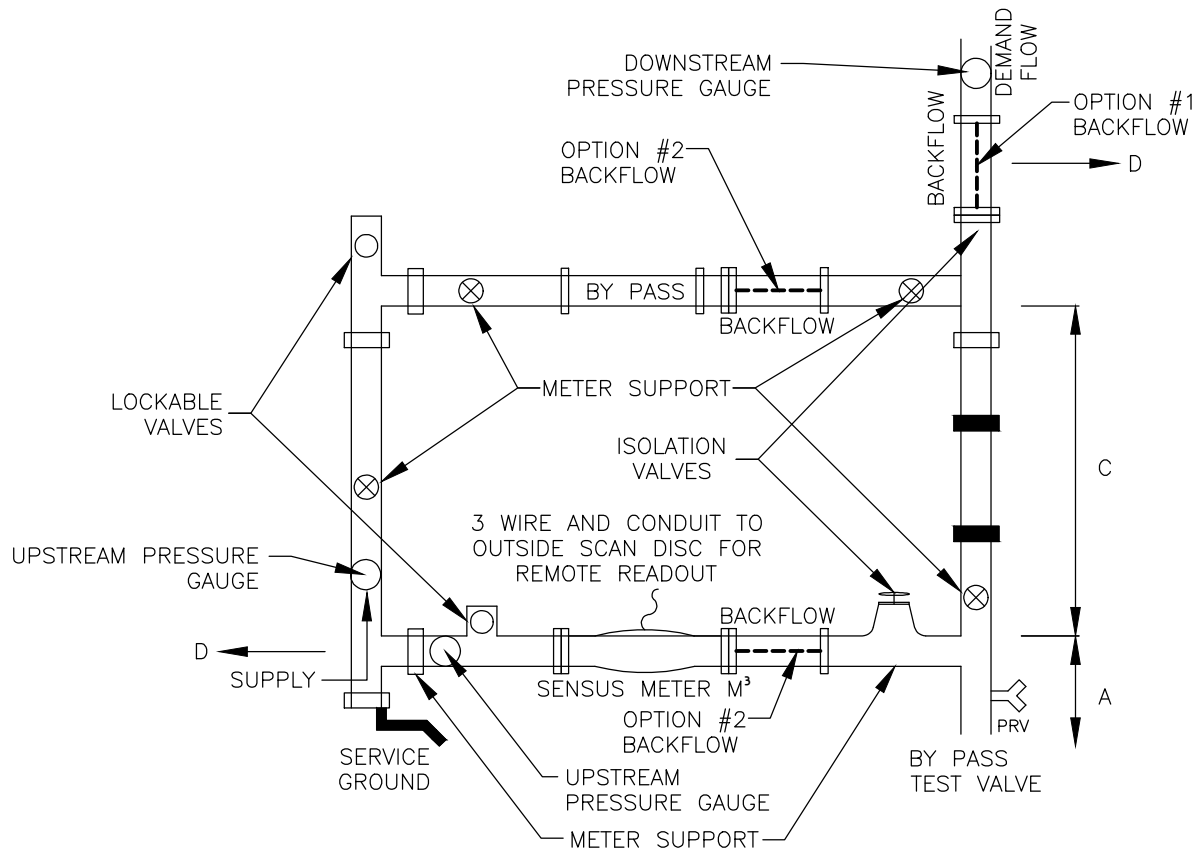

| MINIMUM CLEARANCE TABLE | |
|-------------------------|--|
| A | BOTTOM OF SERVICE TO FLOOR 300mm-500mm MAX |
| B | TO OF REGISTER TO BY PASS OF OBSTRUCTION 1m MIN. |
| C | REAR SERVICE TO WALL 150mm MIN |
| D | PIPING TO ANY OBSTRUCTION 200mm MIN |
| E | SCAN DISC FROM FINISH GRADE 1.0-1.5m |
| F | FRONT CORNER OR SIDE OF FRONT 0-1.0m MAX. |

INSTALLATION NOTES – COMMERCIAL

1. PRE INSPECTION REQUIRED BY TOWN PRIOR TO COMMENCEMENT OF WORK.
2. BY PASS LINE MUST EQUAL SERVICE LINE IN SIZE.
3. FLOOR DRAIN MUST BE WITHIN 2m OF SERVICE.
4. WORKING AREA MUST BE 2m MINIMUM AT SERVICE FLOOR TO ANY OVERHEAD OBSTRUCTION.
5. TEST DRAIN AND PRV MUST BE LOCATED IN OUTGOING SUPPLY BETWEEN SERVICE VALVES AS PER DRAWING.
6. A PRESSURE EXPANSION TANK AND/OR PRESSURE RELIEF VALVE IS REQUIRED TO PROTECT THE BUILDING FROM OVERPRESSURE DUE TO THERMAL EXPANSION. SHOULD AN EXPANSION TANK BE INSTALLED, THIS DEVICE MUST NOT BE INSTALLED ON THE METER RISER LINE TO THE CEILING, BUT BETWEEN CEILING AND COLD INLET LINE TO HOT WATER TANK. IT MUST BE WELL SUPPORTED TO CARRY THE WEIGHT AND LINE SHOCK OF THE WATER. THE INSTALLING PLUMBER WILL BE RESPONSIBLE TO DETERMINE THE SIZE & LOCATION OF THE EXPANSION TANK.
7. SUPPLY VALVES FOR SERVICE AND BY PASS MUST BE LOCKABLE TYPE.
8. METER AND PIPING SUPPORT MUST BE PROVIDED.
9. METER TYPE SENSUS FOR 1m³ REGISTER WITH RADIO READ BOX 510 MODEL USING CONDUIT AND 3 CONDUCTOR 22 GAUGE WIRE FROM METER TO REMOTE READER.
10. METER GROUND TO BE ON INLET SUPPLY USING MINIMUM #8 STANDARD COPPER AND GROUND CLAMPS AS PER PIPE SIZE.
11. CLEAR ACCESS REQUIRED AT ALL TIMES FOR READING, SERVICE, AND INSPECTION.
12. MUST BE HEATED ENVIRONMENT WITH ADEQUATE LIGHTING.
13. UPON COMPLETION, CALL TOWN PUBLIC WORKS FOR FINAL INSPECTION.
14. BACKFLOW PREVENTOR OPTION #1 – BACKFLOW PREVENTOR DOWNSTREAM OF BYPASS LOOP.
15. BACKFLOW PREVENTOR OPTION #2 – FOR BUILDINGS THAT NEED CONTINUOUS FLOW AND DON'T WANT THE WATER TO BE SHUT OFF. TWO BACKFLOWS CAN BE INSTALLED. ONE AFTER THE WATER METER AND ANOTHER IN THE BYPASS LOOP.
16. PRESSURE GAUGE – ONE GAUGE ON THE SUPPLY COMING IN AND ANOTHER AFTER THE BYPASS DOWN STREAM OF THE BACKFLOW PREVENTOR(S).



TYPICAL COMMERCIAL METER INSTALLATION (38mm TO 50mm)



| NO. | REVISIONS | DATE | APR'D |
|-----|-----------|------|-------|
| | | | |
| | | | |
| | | | |

SCALE: N.T.S.
 DATE: NOV. 2021
ERIN SD.
408

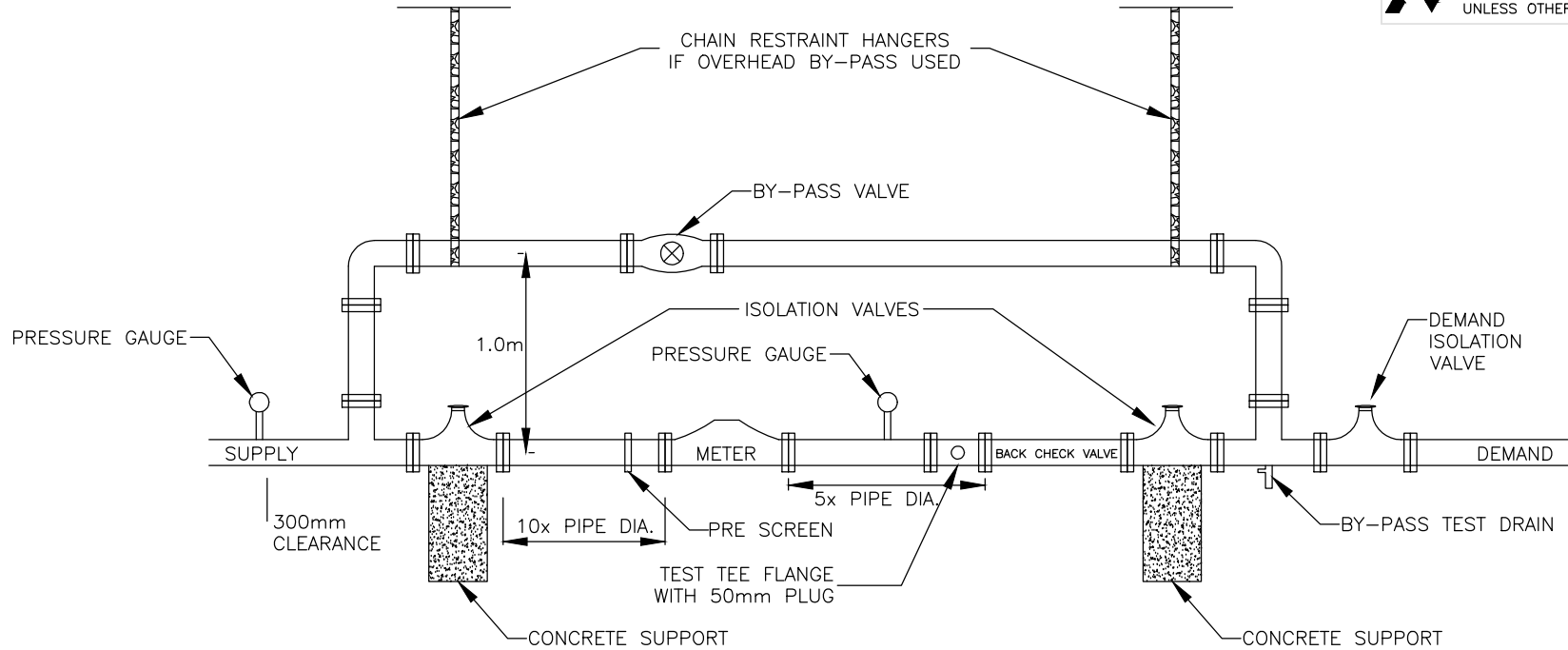

INSTALLATION NOTES – INDUSTRIAL, COMMERCIAL, INSTITUTIONAL

1. PRE-INSPECTION REQUIRED BY TOWN PRIOR TO COMMENCEMENT OF WORK (WATER SERVICE AND PIPING).
2. ALL EQUIPMENT IS TO BE HOUSED ABOVE GROUND, IN A HEATED AND ADEQUATELY LIT ROOM OR BUILDING WITH ACCESS AVAILABLE AT ALL TIMES FOR SERVICING EQUIPMENT.
3. WORKING AREA MUST BE 2 METRES MINIMUM FROM FLOOR TO ANY OVERHEAD OBSTRUCTION AND CLEAR OF ANY OBSTRUCTIONS.
4. METER TYPE TO BE APPROVED BY TOWN, USING INVENSYS ECR REGISTER TO 1cu.m WITH RADIO READ BOX MODEL 510.
5. REMOTE READER WIRING MUST BE 22 GAUGE, 3 CONDUCTOR WIRE, USING CONDUIT FROM METER TO REMOTE READ LOCATION.
6. STAINLESS STEEL PIPING IS RECOMMENDED.
7. BY-PASS LINE MUST EQUAL SERVICE LINE SIZE.
8. FLOOR DRAIN MUST BE WITHIN 2 METRES OF SERVICE.
9. TEST TEE MUST BE FLANGED WITH THREADED 50mm PLUG.
10. BY-PASS TEST DRAIN MUST BE LOCATED BETWEEN BY-PASS VALVE, SERVICE ISOLATION VALVE AND DEMAND ISOLATION VALVE.
11. PRESSURE GAUGES ARE TO BE INSTALLED PRIOR TO BY-PASS LINE AND AFTER METER.
12. ALL VALVES MUST BE WHEEL TYPE AND LOCKABLE EXCEPT SMALL SERVICE VALVES.
13. METER AND PIPING MUST BE SUPPORTED AS PER DRAWING OR EQUIVALENT.
14. METER EQUIPMENT MUST BE EARTH GROUNDED.
15. CALIBRATION AND BACKFLOW TESTING RESULTS TO BE PROVIDED TO TOWN.
16. UPON COMPLETION OF THE COMPLETE METER INSTALLATION AND TESTING, CONTACT THE PUBLIC WORKS DEPARTMENT FOR FINAL INSPECTION.



**ICI WATER METER INSTALLATION
75mm AND LARGER**

| | | | |
|-----|-----------|------|-------|
| | | | |
| | | | |
| | | | |
| | | | |
| | | | |
| NO. | REVISIONS | DATE | APR'D |

SCALE: N.T.S.

DATE: NOV. 2021

**ERIN SD.
409**

PRIVATE LAND

PUBLIC LAND

SWM FACILITY

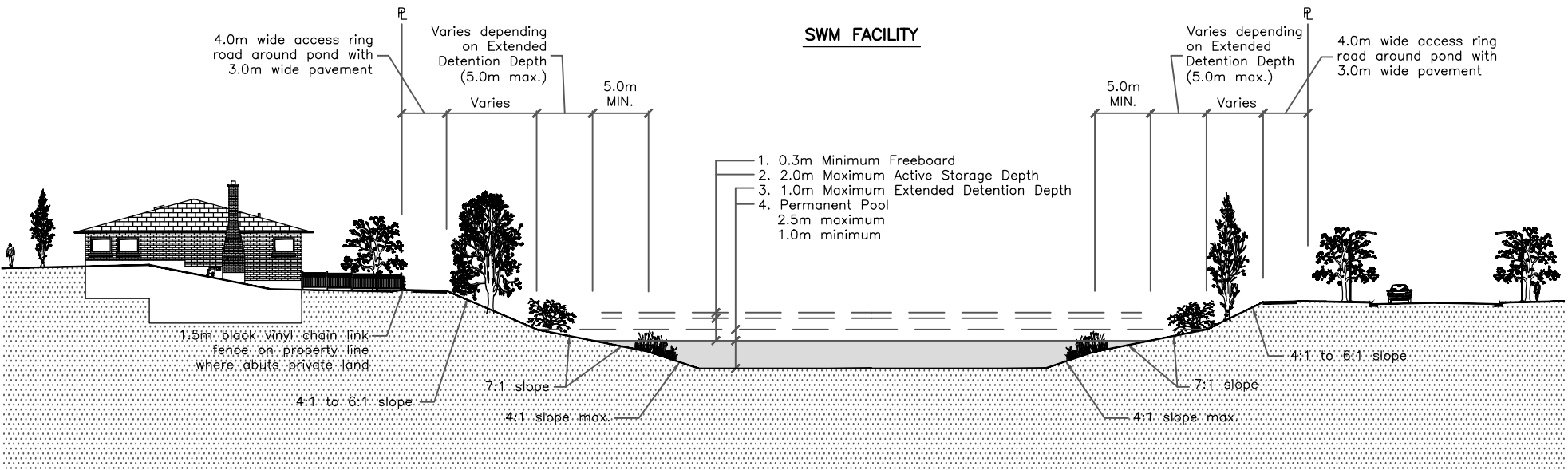

NOTES:

1. For all wet ponds and wetlands, vegetation strategies are required in all areas, including dry and permanent wet areas.
2. For sediment forebay design refer to ERIN SD. 503.
3. Slope and depth must meet MOE preferred pond criteria.



TYPICAL WET POND

SCALE: N.T.S.

DATE: NOV. 2021

ERIN SD.
501

| NO. | REVISIONS | DATE | APR'D |
|-----|-----------|------|-------|
| | | | |
| | | | |
| | | | |

PRIVATE LAND

PUBLIC LAND

SWM FACILITY

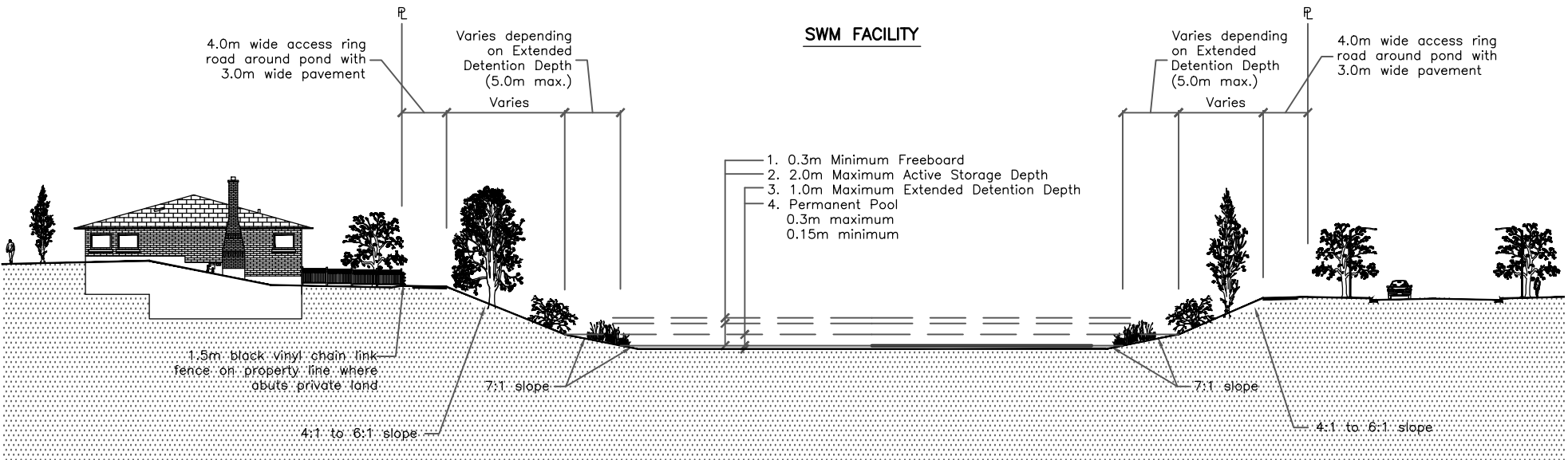

NOTES:

1. For all wet ponds and wetlands, vegetation strategies are required in all areas, including dry and permanent wet areas.
2. For sediment forebay design refer to ERIN SD. 503.
3. For micropool design refer to ERIN SD. 504.
4. Slope and depth must meet MOE preferred pond criteria.

| NO. | REVISIONS | DATE | APR'D |
|-----|-----------|------|-------|
| | | | |
| | | | |
| | | | |



METRIC
ALL DIMENSIONS ARE IN METRES
UNLESS OTHERWISE SHOWN

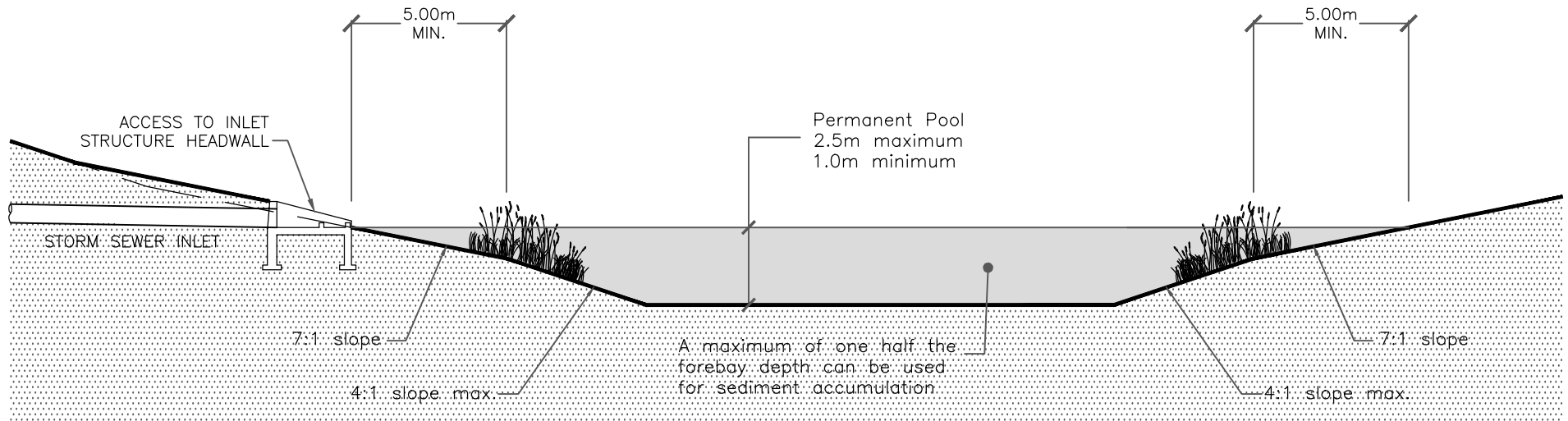

TOWN OF
ERIN

SEDIMENT FOREBAY DETAIL

| NO. | REVISIONS | DATE | APR'D |
|-----|-----------|------|-------|
| | | | |
| | | | |
| | | | |

SCALE: N.T.S.

DATE: NOV. 2021

**ERIN SD.
503**

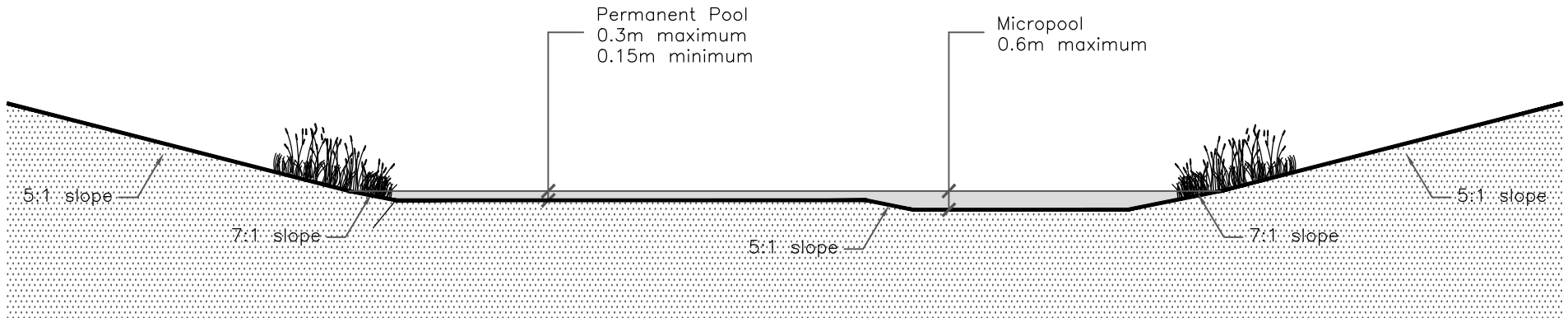

NOTE:

Micropools shall have an additional maximum depth of 0.3m below the permanent pool level.
 Micropools shall not exceed 5% of the total permanent pool surface area.



WETLAND MICROPOOL DETAILS

| NO. | REVISIONS | DATE | APR'D |
|-----|-----------|------|-------|
| | | | |
| | | | |
| | | | |

SCALE: N.T.S.
 DATE: NOV. 2021
ERIN SD.
504

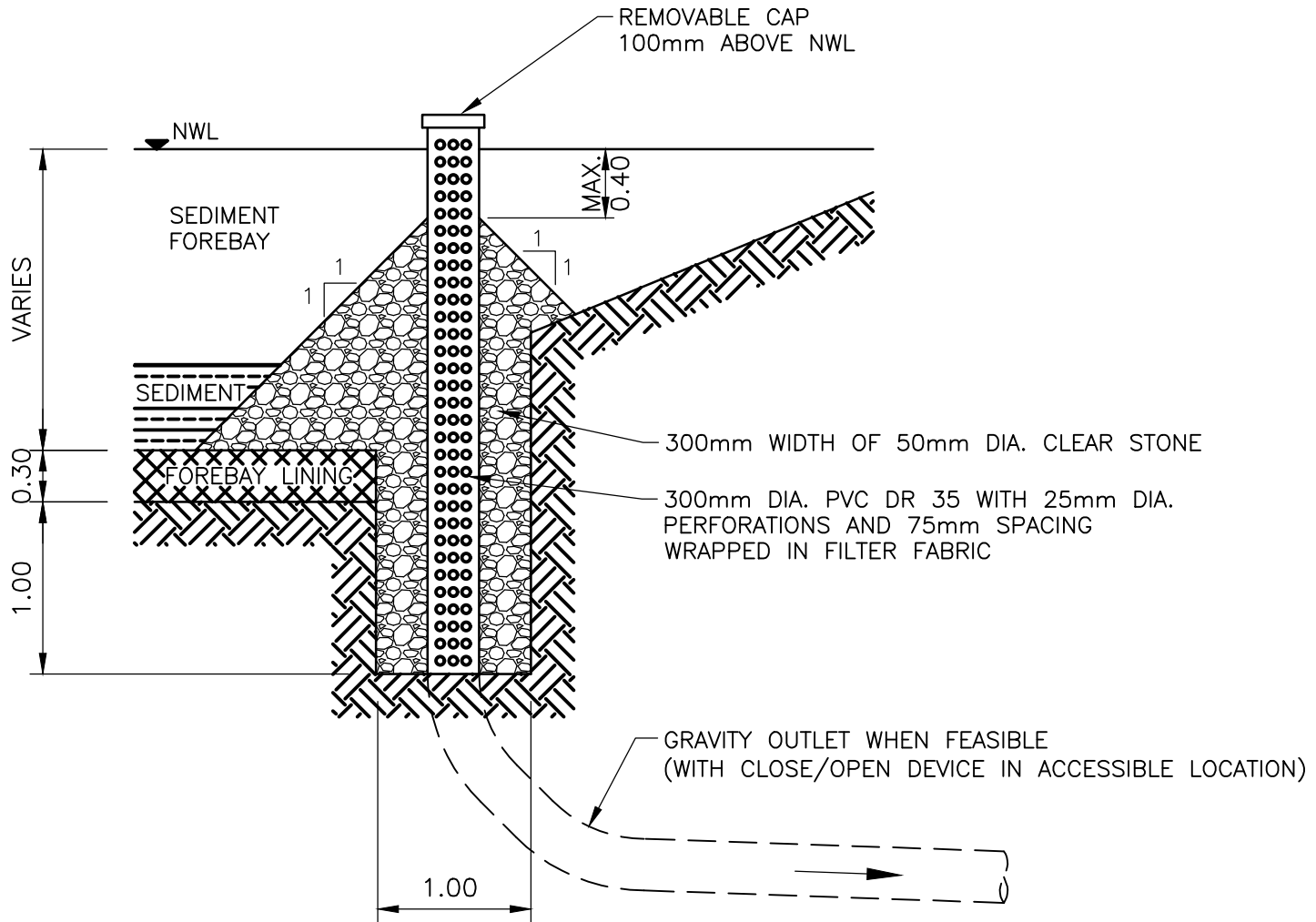

| NO. | REVISIONS | DATE | APR'D |
|-----|-----------|------|-------|
| | | | |
| | | | |
| | | | |



METRIC
ALL DIMENSIONS ARE IN METRES
UNLESS OTHERWISE SHOWN

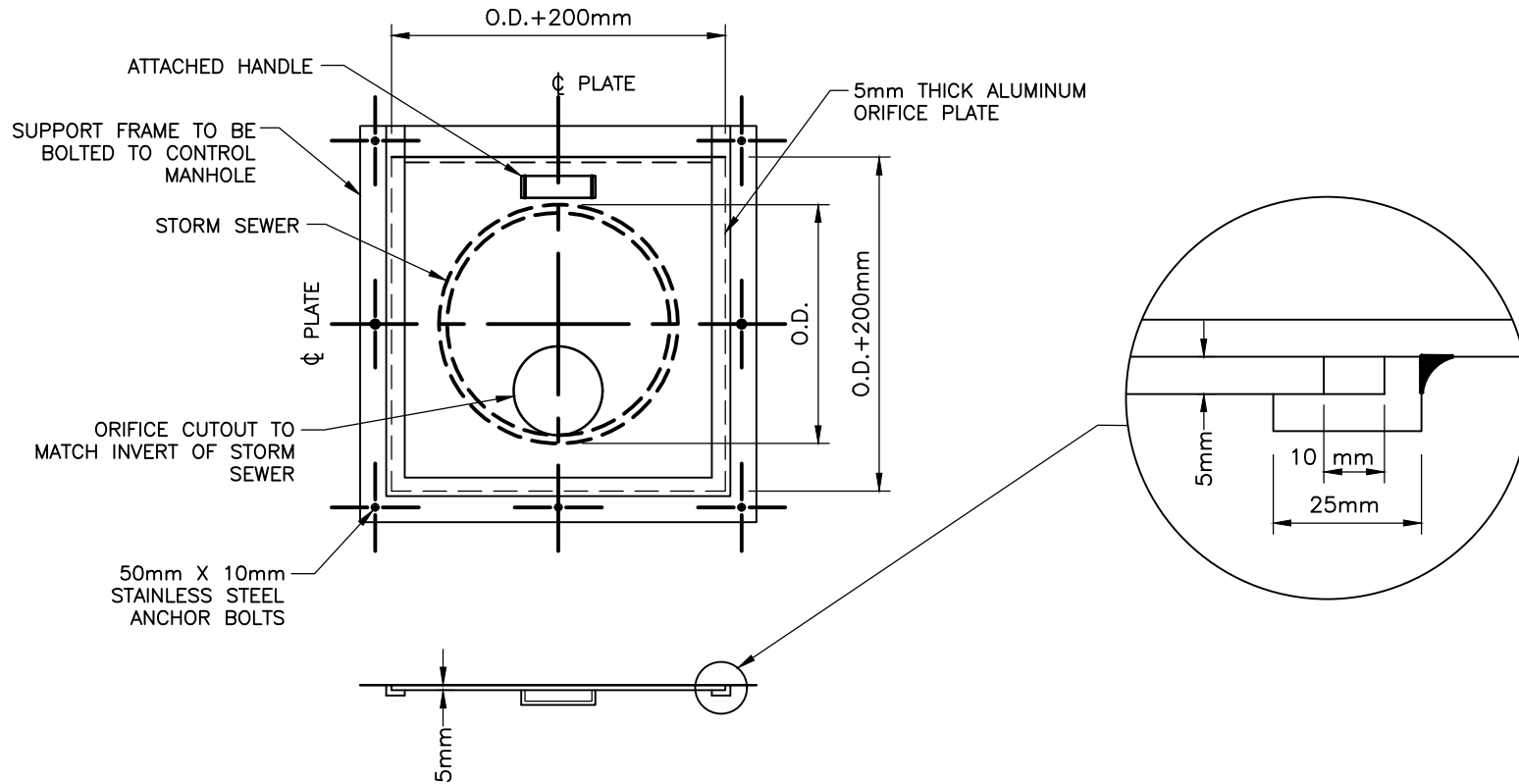

TOWN OF
ERIN

**STORM WATER POND
ORIFICE PLATE DETAIL**

| NO. | REVISIONS | DATE | APR'D |
|-----|-----------|------|-------|
| | | | |
| | | | |
| | | | |

SCALE: N.T.S.

DATE: NOV. 2021

**ERIN SD.
506**

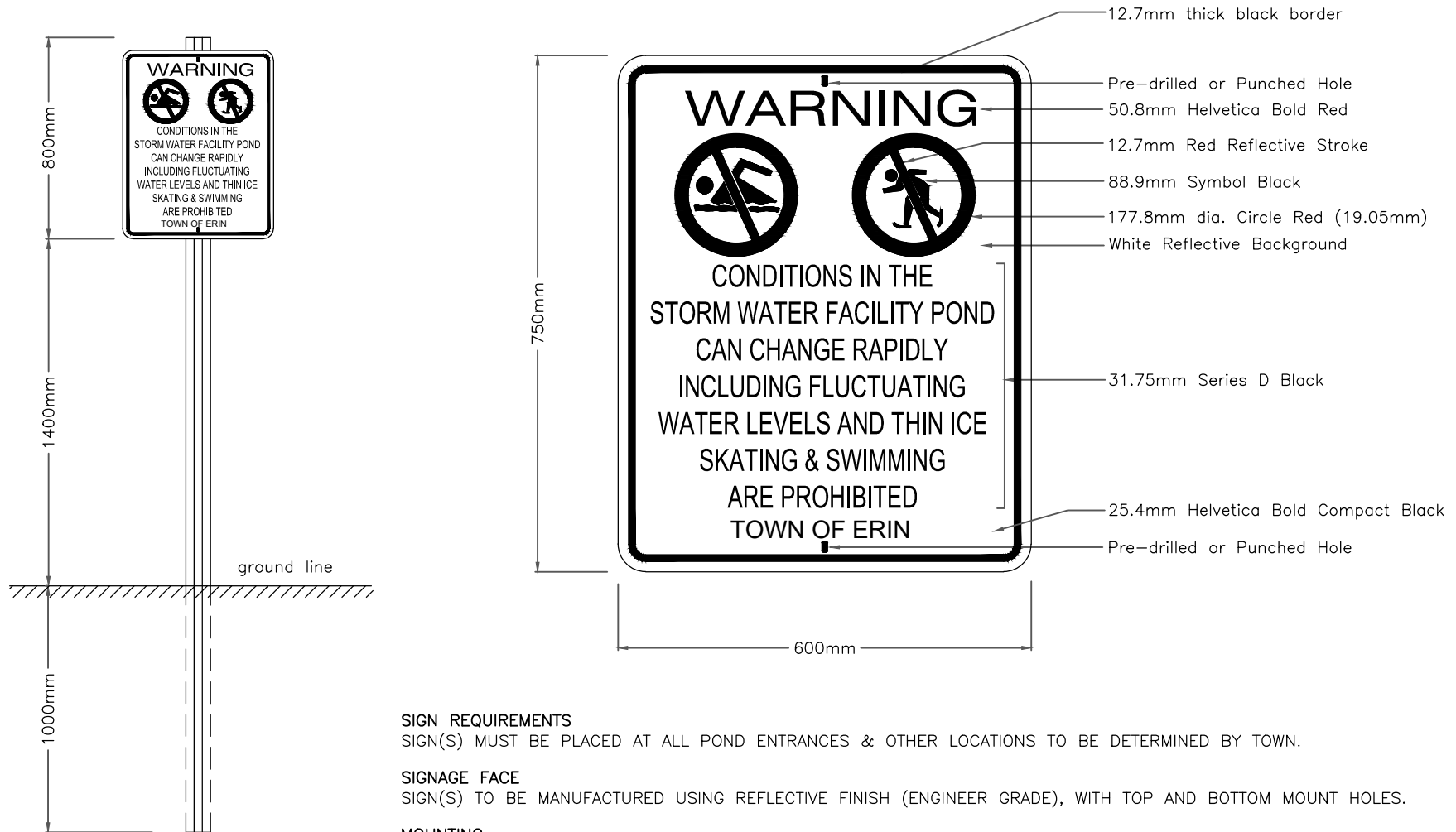

SIGN REQUIREMENTS

SIGN(S) MUST BE PLACED AT ALL POND ENTRANCES & OTHER LOCATIONS TO BE DETERMINED BY TOWN.

SIGNAGE FACE

SIGN(S) TO BE MANUFACTURED USING REFLECTIVE FINISH (ENGINEER GRADE), WITH TOP AND BOTTOM MOUNT HOLES.

MOUNTING

SIGN(S) TO BE MOUNTED TO 3.8m U-CHANNEL GALVANIZED STEEL POST.



SCALE: N.T.S.

DATE: MAR. 2011

**TNT.SD.
507**

STORM WATER FACILITY POND WARNING SIGN

| NO. | REVISIONS | DATE | APR'D |
|-----|-----------|------|-------|
| | | | |
| | | | |
| | | | |

INSTALLATION PLAN

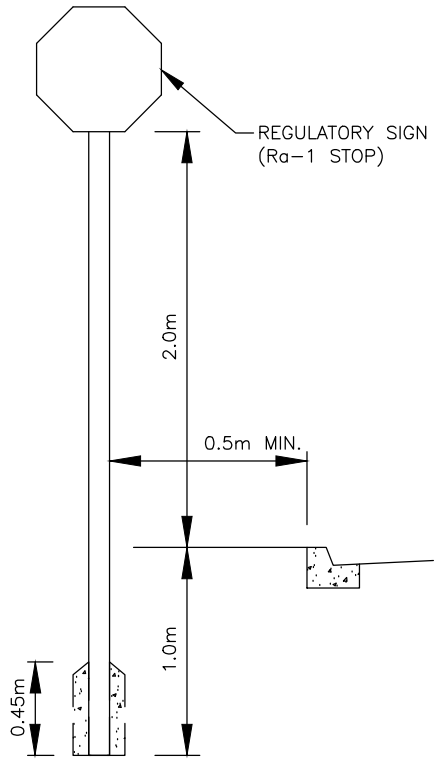

LOCATION PLAN

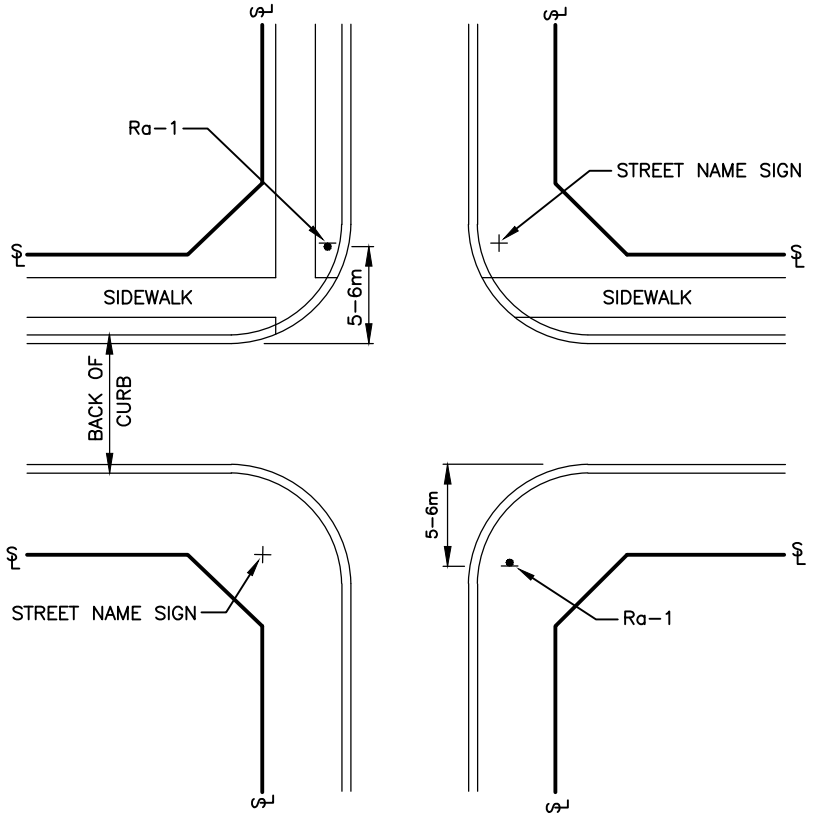

NOTES:

1. REGULATORY/WARNING SIGNS AS PER OHTA REG. 615/616 OR AMENDMENTS THEREOF.
2. STOP SIGNS (Ra-1) POSTS SHALL BE 60mm x 3.65m GALVANIZED STEEL COMPLETE WITH TOP.
3. STOP SIGNS SHALL BE BANDED TO THE POST WITH MINIMUM 12.7mm x 0.76mm STAINLESS STEEL BANDING AND FLARED LEG STAINLESS STEEL BASKETS (BANDRIT MINI BRACKETS OR EQUIVALENT).
4. ALL OTHER REGULATORY/WARNING SIGNS SHALL BE MOUNTED ON 3.66m 80,000psi U FLANGE POSTS WHICH HAVE THE TOP 1200mm PUNCHED ON 50mm CENTRES WITH 11mm HOLES.
5. ALL REGULATORY AND WARNING SIGNS SHALL BE MOUNTED A MINIMUM OF 2m ABOVE FINISHED GROUND ELEVATION IN URBAN AREAS.
6. ALL REGULATORY AND WARNING SIGN BLANKS SHALL BE GALVANIZED STEEL AND BE OF HIGH DENSITY GRADE REFLECTORIZED SURFACES.



STREET SIGNS

| NO. | REVISIONS | DATE | APR'D |
|-----|-----------|------|-------|
| | | | |
| | | | |
| | | | |

| |
|-------------------------|
| SCALE: N.T.S. |
| DATE: NOV. 2021 |
| ERIN SD. 601 |

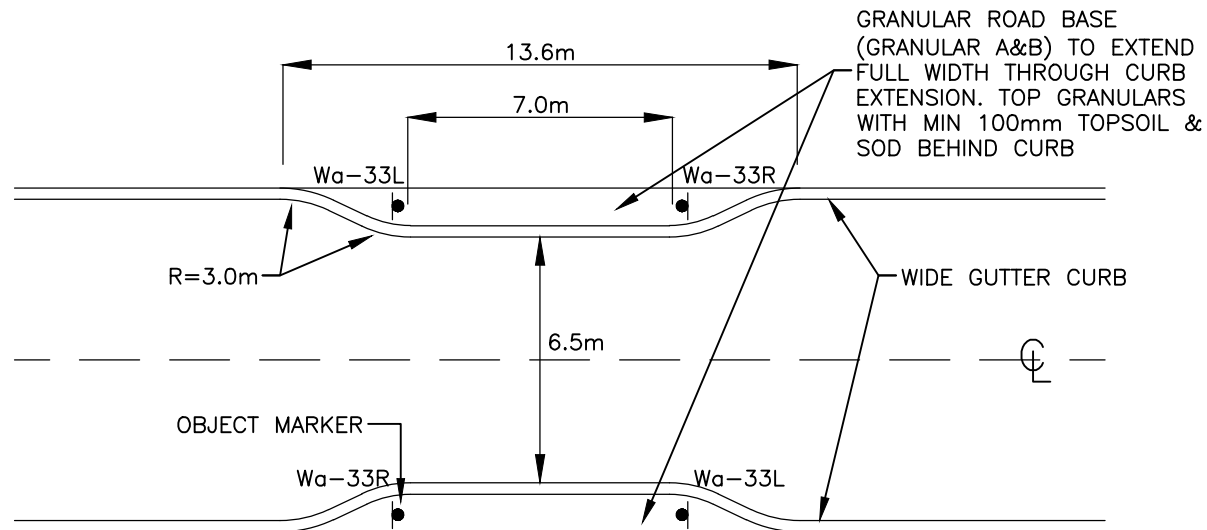

| NO. | REVISIONS | DATE | APR'D |
|-----|-----------|------|-------|
| | | | |
| | | | |
| | | | |



ACCESSIBLE PARKING SIGN DETAIL

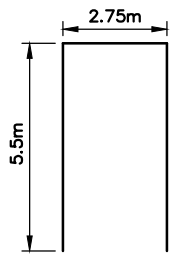

STANDARD

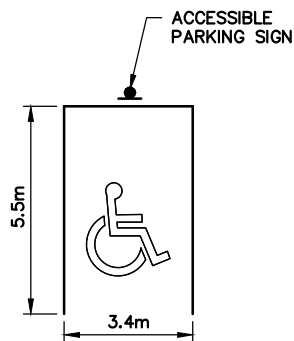

BARRIER FREE
(TYPE A)

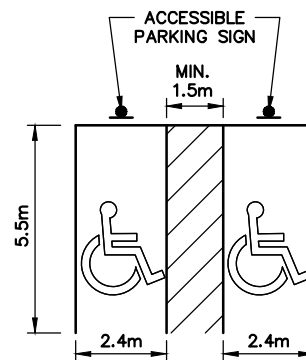

BARRIER FREE
(TYPE B)



**PARKING SPACE
DIMENSIONS**



METRIC
ALL DIMENSIONS ARE
IN METRES UNLESS
OTHERWISE SHOWN

NO.

REVISIONS

DATE

APR'D

SCALE: N.T.S.
DATE: NOV. 2021

**ERIN SD.
607**

NOTES:

1. ALL WORKS SHALL BE CONSTRUCTED IN ACCORDANCE WITH CURRENT TOWN OF ERIN, COUNTY OF WELLINGTON, APPROPRIATE CONSERVATION AUTHORITY AND ONTARIO PROVINCIAL STANDARD DRAWINGS AND SPECIFICATIONS.
2. ALL WORK SHALL BE COMPLETED IN ACCORDANCE WITH THE "OCCUPATIONAL HEALTH AND SAFETY ACT". THE GENERAL CONTRACTOR SHALL BE DEEMED TO BE THE CONSTRUCTOR AS DEFINED IN THE ACT.
3. THE LOCATION OF ALL UNDERGROUND AND ABOVEGROUND UTILITIES AND STRUCTURES ARE NOT NECESSARILY SHOWN ON THE CONTRACT DRAWINGS, AND WHERE SHOWN, THE ACCURACY OF THE LOCATION OF SUCH UTILITIES AND STRUCTURES IS NOT GUARANTEED. BEFORE STARTING WORK THE CONTRACTOR SHALL INFORM HIMSELF OF THE EXACT LOCATION OF ALL SUCH UTILITIES AND STRUCTURES AND SHALL ASSUME ALL LIABILITY FOR DAMAGE TO THEM.
4. ALL DIMENSIONS AND ELEVATIONS SHALL BE CHECKED AND VERIFIED IN THE FIELD BY THE CONTRACTOR PRIOR TO ANY CONSTRUCTION AND HE SHALL REPORT ANY DISCREPANCIES TO THE CONSULTANT IMMEDIATELY. DETAILS ARE NOT TO BE SCALED FROM THE DRAWINGS. ALL DIMENSIONS ARE SHOWN IN S.I. UNITS UNLESS OTHERWISE NOTED.
5. ALL CONCRETE AND PLASTIC SEWER PIPES SHALL HAVE RUBBER GASKET JOINTS.
6. ALL CONCRETE SEWERS SHALL BE CONSTRUCTED WITH BEDDING AS PER OPSD 802.030 CLASS 'B' AND BEDDING MATERIAL TO BE GRANULAR 'A' UNLESS OTHERWISE RECOMMENDED BY THE GEOTECHNICAL ENGINEER.
7. ALL PLASTIC SEWERS SHALL BE CONSTRUCTED WITH BEDDING AS PER OPSD 802.010 AND BEDDING MATERIAL TO BE GRANULAR 'A' UNLESS OTHERWISE RECOMMENDED BY THE GEOTECHNICAL ENGINEER.
8. ALL BACKFILL FOR SEWERS, WATERMAINS AND UTILITIES ON THE ROAD ALLOWANCE MUST BE MECHANICALLY COMPACTED TO 100% STANDARD PROCTOR DENSITY, UNLESS OTHERWISE RECOMMENDED BY GEOTECHNICAL ENGINEER.
9. SEWER MAINTENANCE HOLE FRAME AND COVERS TO BE AS PER O.P.S.D. 401.010 TYPE 'A', STAMPED "SANITARY", "STORM" AND/OR "FDC" AS APPROPRIATE.
10. MAINTENANCE HOLE AND CATCHBASIN ADJUSTMENT UNITS SHALL BE A MAXIMUM OF 300mm IN HEIGHT AND THREE UNITS.
11. GRANULAR BACKFILL AROUND MAINTENANCE HOLES, CATCHBASINS AND VALVE CHAMBERS SHALL BE GRANULAR 'B' COMPACTED BY MECHANICAL MEANS TO A MINIMUM OF 98% STANDARD PROCTOR DENSITY.
12. RISERS ARE REQUIRED ON ALL STORM AND SANITARY CONNECTIONS WHERE COVER ON THE MAIN SEWER EXCEEDS 4.5m AS PER O.P.S.D. 1006.020.
13. ALL AREAS BEYOND THE SITE LIMITS WHICH ARE DISTURBED DURING CONSTRUCTION SHALL BE RESTORED TO ORIGINAL CONDITION OR BETTER.
14. CHAIN LINK FENCING SHALL BE AS PER OPSD 972.130 WITH ALL COMPONENTS BLACK VINYL COATED AND HEIGHT AS SPECIFIED ON THE DRAWINGS.
15. EROSION AND SEDIMENT CONTROL MEASURES TO BE IN PLACE PRIOR TO START OF ANY CONSTRUCTION, AND MUST BE MAINTAINED AT ALL TIMES, IN ACCORDANCE WITH THE APPROVED EROSION AND SEDIMENT CONTROL PLAN.
16. ALL CONSTRUCTION SIGNAGE MUST CONFORM TO THE M.T.O. ONTARIO TRAFFIC MANUAL – BOOK 7 LATEST EDITION.



GENERAL NOTES



METRIC
ALL DIMENSIONS ARE
IN METRES UNLESS
OTHERWISE SHOWN

| NO. | REVISIONS | DATE | APR'D |
|-----|-----------|------|-------|
| | | | |
| | | | |
| | | | |

SCALE: N.T.S.
DATE: NOV. 2021
ERIN SD.
700

NOTES:

1. ALL SANITARY SERVICE CONNECTIONS TO DWELLINGS SHALL BE 125mm DIAMETER P.V.C. SDR-28 LAID AT A MINIMUM SLOPE OF 2%, AND SHALL BE GREEN IN COLOUR.
2. A TEST FITTING SHALL BE INSTALLED AT THE PROPERTY LINE.
3. ALL SERVICE CONNECTIONS TO BE MARKED WITH A 50mm x 100mm WOOD STAKE, PROJECTING 1.0m ABOVE THE GROUND, WITH THE TOP 300mm PAINTED GREEN.
4. CONNECTIONS TO EXISTING SANITARY SEWER TO BE MADE USING PIPE CUTTER AND APPROVED SADDLES.
5. ALL SEWERS SHALL BE INSTALLED WITH LASER AND CHECKED PRIOR TO BACKFILLING.
6. MAINTENANCE HOLE PIPE OPENING AND BENCHING DETAILS TO BE AS PER O.P.S.D. 701.021.
7. SANITARY SERVICES TO HAVE A MIN. 2.7m COVER AT THE STREET LINE, UNLESS OTHERWISE NOTED.
8. FROST STRAPS TO BE INSTALLED AS PER O.P.S.D # 701.100



SANITARY SEWER SYSTEM



METRIC
ALL DIMENSIONS ARE
IN METRES UNLESS
OTHERWISE SHOWN

| NO. | REVISIONS | DATE | APR'D |
|-----|-----------|------|-------|
| | | | |
| | | | |
| | | | |

SCALE: N.T.S.
DATE: NOV. 2021
ERIN SD.
701

NOTES:

1. ALL STORM SERVICE CONNECTIONS TO DWELLINGS SHALL BE 125mm DIAMETER (SINGLE) AND 150mm DIAMETER (DOUBLE) P.V.C. SDR-28 LAID AT A MINIMUM SLOPE OF 2%, AND SHALL BE ONLY WHITE IN COLOUR.
2. A TEST FITTING SHALL BE INSTALLED AT THE PROPERTY LINE.
3. ALL SERVICE CONNECTIONS TO BE MARKED WITH A 50mm x 100mm WOOD STAKE, PROJECTING 1.0m ABOVE THE GROUND, WITH THE TOP 300mm PAINTED ORANGE.
4. SINGLE CATCHBASINS TO BE PRECAST CONCRETE WITH CAST IRON FRAME AND GRATE CONFORMING TO O.P.S.D. 705.010 AND DOUBLE CATCHBASINS TO BE PRECAST CONCRETE WITH CAST IRON FRAME AND GRATE CONFORMING TO O.P.S.D. 705.020. THE CATCH BASIN GRATES SHALL BE THE FISH STYLE GRATES MANUFACTURED BY BIBBY-STE-CROIX DETAIL JW107AF AND DOUBLE CATCH BASIN GRATE AS PER JW100AF OR AS APPROVED BY THE TOWN.
5. CONTRACTOR SHALL ENSURE THAT THE LOW POINT OF CURBS COINCIDE WITH THE LOCATION OF CATCHBASINS INSTALLED AT ROADWAY SAG AREAS.
6. CATCHBASIN CONNECTIONS TO THE CURB SUBDRAIN SYSTEM TO BE IN ACCORDANCE WITH O.P.S.D. 216.021.
7. SINGLE CATCHBASIN LEADS TO BE 250mm LAID AT A MINIMUM SLOPE OF 1% UNLESS OTHERWISE NOTED. DOUBLE CATCHBASIN LEADS TO BE 300mm LAID AT A MINIMUM SLOPE OF 1% UNLESS OTHERWISE NOTED. ALL CATCHBASIN LEADS TO BE EITHER CONCRETE OR P.V.C. SDR-35 UNLESS OTHERWISE NOTED.
8. ROAD CATCHBASIN LEAD INVERTS TO BE 1.5m BELOW GRATE ELEVATION, UNLESS OTHERWISE REQUIRED FOR POSITIVE DRAINAGE TO MAIN LINE SEWER.
9. MAINTENANCE HOLE BENCHING AND PIPE OPENING DETAILS TO BE AS PER O.P.S.D. 701.021.
10. STORM SERVICES TO HAVE A MIN. 2.5m COVER AT THE STREET LINE UNLESS OTHERWISE NOTED.
11. REAR LOT CATCHBASINS TO BE SUMPLESS PRECAST CONCRETE WITH STEEL FRAME AND GRATE CONFORMING TO O.P.S.D. 705.010 AND O.P.S.D. 400.120.
12. REAR LOT CATCHBASIN LEADS ARE TO BE CONCRETE ENCASED FOR THE FULL LENGTH OF THE LOT AND TO THE BACK OF THE STREET CURB.
13. NO CATCH BASIN SHALL BE LOCATED IN THE PROPOSED AREAS OF DRIVEWAYS.
14. CONNECTIONS TO EXISTING SANITARY SEWER TO BE MADE USING PIPE CUTTER AND APPROVED SADDLES.
15. ALL SEWERS SHALL BE INSTALLED WITH LASER AND CHECKED PRIOR TO BACKFILLING.
16. FROST STRAPS TO BE INSTALLED AS PER O.P.S.D # 701.100.



STORM SEWER SYSTEM



| NO. | REVISIONS | DATE | APR'D |
|-----|-----------|------|-------|
| | | | |
| | | | |
| | | | |

SCALE: N.T.S.
DATE: NOV. 2021

**ERIN SD.
702**

NOTES:

1. P.V.C. WATERMAIN TO CONFORM TO LATEST A.W.W.A. SPECIFICATIONS.
2. WATER SERVICES TO BE 25mm TYPE 'K' COPPER UNLESS OTHERWISE SPECIFIED.
3. WATERMAIN TO HAVE A MINIMUM 1.70m COVER OR 1.9m BELOW CENTRELINE OF ROAD, WHICHEVER IS DEEPER.
4. WATER SERVICES ARE TO HAVE MINIMUM 1.90m COVER.
5. WATER SERVICES TO HAVE 1.2m MINIMUM HORIZONTAL CLEARANCE FROM MAINTENANCE HOLES AND CATCHBASINS, AND 1.00m MINIMUM HORIZONTAL CLEARANCE FROM ALL OTHER UTILITIES.
6. FIRE HYDRANTS TO CONFORM TO A.W.W.A C502 AND TO BE INSTALLED AS PER O.P.S.D. 1105.010 WITH 2 – 63.5mm INSIDE DIAMETER HOSE NOZZLES AT 180 DEGREES AND 1 – 100mm STORZ PUMPER NOZZLE, WITH OPERATING NUT "OPEN LEFT" (COUNTER–CLOCKWISE). HYDRANTS SHALL BE PAINTED IN ACCORDANCE WITH NATIONAL FIRE PROTECTION ASSOCIATION (NFPA) STANDARDS.
7. WATERMAIN BEDDING SHALL BE AS PER OPSD 802.010 AND BEDDING MATERIAL TO BE GRANULAR 'A' UNLESS OTHERWISE RECOMMENDED BY THE GEOTECHNICAL ENGINEER.
8. ALL PVC WATERMAINS SHALL BE INSTALLED WITH A WHITE PLASTIC COATED 12 GAUGE SOLID COPPER TRACER WIRE WHICH SHALL BE BROUGHT TO THE SURFACE AT ALL SECONDARY VALVES AND MAIN LINE VALVES.
9. VALVE IN BOXES SHALL BE INSTALLED AS PER O.P.S.D 1101.020 AND CONFORM TO A.W.W.A. C500. MAINLINE VALVES TO BE MECHANICALLY RESTRAINED.
10. CATHODIC PROTECTION IS REQUIRED ON ALL METALLIC FITTINGS. WEIGHT OF THE ANODES TO BE MINIMUM 5.4 kg (12 lbs.), UNLESS OTHERWISE RECOMMENDED BY THE GEOTECHNICAL CONSULTANT.
11. ALL PLUGS, CAPS, TEES AND BENDS SHALL BE MECHANICALLY RESTRAINED. RESTRAINING JOINTS SHALL BE AS PER UNI–FLANGE SERIES 1300, OR APPROVED EQUAL.
12. ADAPTER FLANGES AT VALVES, METERS, ETC., SHALL BE AS PER UNI–FLANGE 900C, OR APPROVED EQUAL.
13. THE OPERATION OF EXISTING WATERMAIN VALVES SHALL BE CONDUCTED BY THE TOWN OF ERIN.
14. THE NEW WATERMAIN TO BE TAPPED FOR WATER SERVICES MUST BE ISOLATED FROM THE EXISTING WATERMAIN. TO MAINTAIN PRESSURE IN THE NEW MAIN DURING INSTALLATION OF SERVICES, A 50mm BY–PASS WITH AN APPROVED DIFFERENTIAL BACKFLOW PREVENTER IS TO BE INSTALLED AROUND THE CLOSED OPERATING VALVE.
15. UNLESS OTHERWISE NOTED, THE MINIMUM HORIZONTAL SEPARATION BETWEEN THE WATERMAIN AND ANY SEWER SHALL BE 2.5m. A MINIMUM VERTICAL SEPARATION OF 0.3m MUST BE MAINTAINED IF WATERMAIN IS ABOVE SEWER, OR 0.5m IF SEWER IS ABOVE WATERMAIN. CLEARANCES ARE MEASURED FROM OUTSIDE EDGES OF PIPES.
16. MINIMUM CURVATURE OF ANY WATERMAIN SHALL BE COMPLETED BY PIPE DEFLECTION IN ACCORDANCE WITH THE MANUFACTURER’S RADIUS GUIDELINES.
17. VALVES SHALL BE RESILIENT SEAT GATE VALVES FOR 300mm DIAMETER OR LESS.
18. ALL SERVICE CONNECTIONS TO BE MARKED WITH A 50mm x 100mm x 2.4m WOOD STAKE, PAINTED BLUE.



WATER DISTRIBUTION SYSTEM



METRIC
ALL DIMENSIONS ARE
IN METRES UNLESS
OTHERWISE SHOWN

NO.

REVISIONS

DATE

APR'D

SCALE: N.T.S.
DATE: NOV. 2021

ERIN SD.
703

NOTES:

1. CATCHBASIN, MAINTENANCE HOLE AND VALVE CHAMBER COVERS SHALL BE SET FLUSH TO BASE COURSE ASPHALT LEVEL AND ADJUSTED TO GRADE PRIOR TO INSTALLING TOP COURSE OF ASPHALT.
2. CURB AND WIDE GUTTER SHALL BE TWO STAGE AS PER TOWN OF ERIN STANDARD DRAWING ERIN SD. 604.
3. SINGLE STAGE CURB AND WIDE GUTTER IF REQUIRED SHALL BE AS PER O.P.S.D. 600.010.
4. CONCRETE FOR CURBS TO CONFORM TO O.P.S.S. 353.
5. TEMPORARY ASPHALT CURB SHALL BE AS PER O.P.S.D. 601.010.
6. SIDEWALKS SHALL BE AS PER O.P.S.D. 310.01 WITH CONCRETE TO CONFORM TO O.P.S.S. 351.
7. UNLESS OTHERWISE RECOMMENDED BY THE GEOTECHNICAL ENGINEER, THE FOLLOWING MINIMUM PAVEMENT STRUCTURES (COMPACTED DEPTH) SHALL BE USED:

| | GRANULAR B | GRANULAR A | BASE ASPHALT | TOP ASPHALT |
|-----------------|------------|------------|--------------|-------------|
| URBAN LOCAL | 300mm | 150mm | 80mm | 40mm |
| MINOR COLLECTOR | 350mm | 150mm | 100mm | 40mm |
| MAJOR COLLECTOR | 400mm | 150mm | 100mm | 40mm |
| ARTERIAL | 450mm | 150mm | 100mm | 40mm |
| INDUSTRIAL | 450mm | 150mm | 100mm | 40mm |
| RURAL | 300mm | 150mm | 50mm | 40mm |

8. RESIDENTIAL DRIVEWAYS SHALL BE PAVED FROM CURB TO GARAGE IN ACCORDANCE WITH THE FOLLOWING PAVEMENT STRUCTURE (COMPACTED DEPTH), AND OTHER DRIVEWAYS SHALL CONSIST OF THE FOLLOWING PAVEMENT STRUCTURE (COMPACTED DEPTH) WITHIN THE MUNICIPAL ROAD ALLOWANCE, UNLESS OTHERWISE RECOMMENDED BY THE GEOTECHNICAL ENGINEER:

| | GRANULAR B | GRANULAR A | HL8 | HL3 |
|---|------------|------------|-------|------|
| RESIDENTIAL | N/A | 150mm | 50mm | 25mm |
| LIGHT INDUSTRIAL, COMMERCIAL, APPARTMENT, CONDOMINIUM, ETC. | 300mm | 150mm | 75mm | 40mm |
| HEAVY INDUSTRIAL | 400mm | 150mm | 100mm | 40mm |

9. UNSHRINKABLE FILL TO BE USED FOR CUTS UNDER EXISTING ROADS AND SHALL EXTEND TO SUBGRADE LEVEL.



ROADS, SIDEWALKS, AND WALKWAYS



METRIC
ALL DIMENSIONS ARE
IN METRES UNLESS
OTHERWISE SHOWN

NO.

REVISIONS

DATE

APR'D

SCALE: N.T.S.
DATE: NOV. 2021

ERIN SD.
704

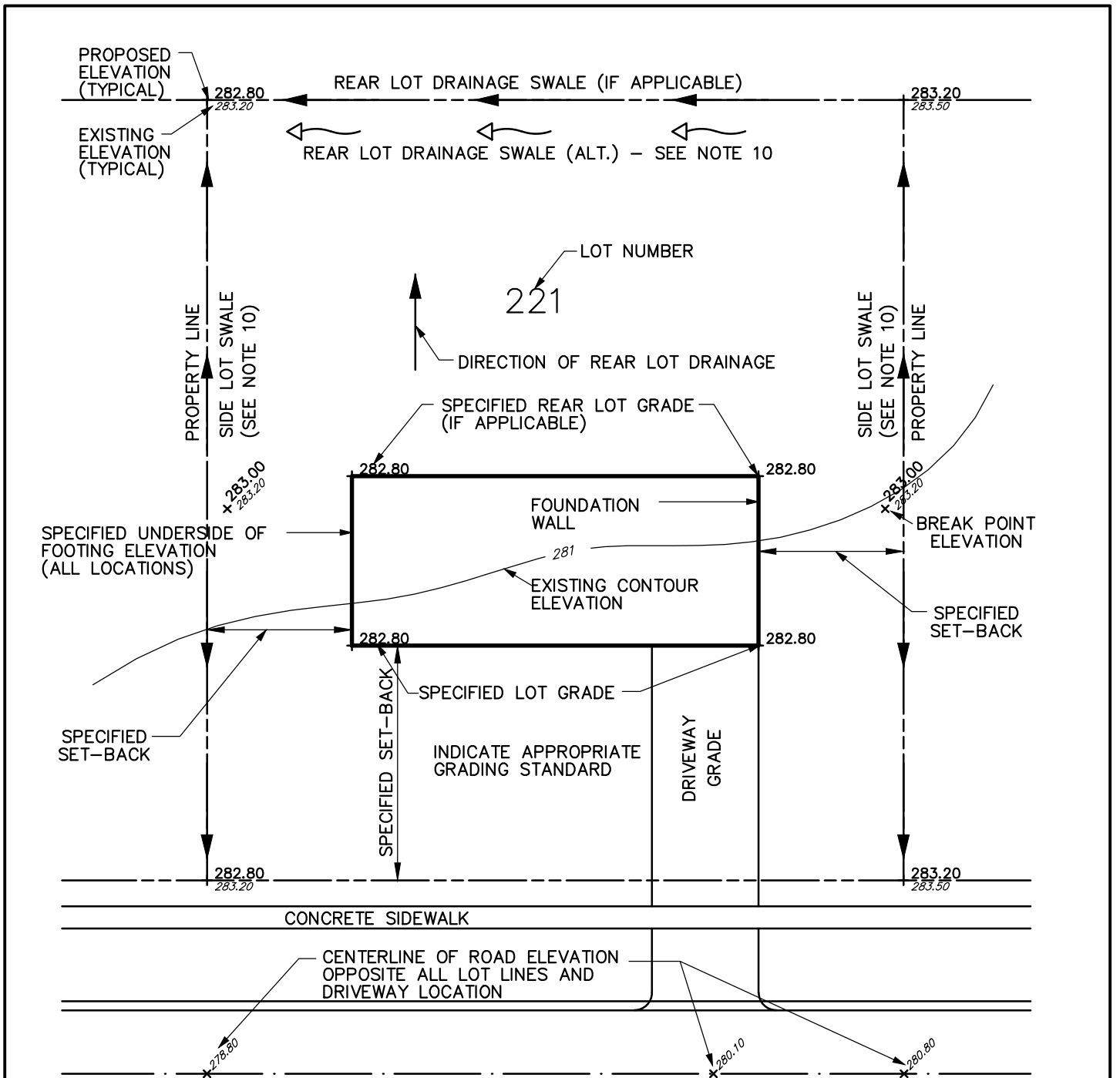

NOTES:

1. ALL CATCHBASIN LOCATIONS MUST BE SHOWN ON GRADING PLAN.
2. ALL EASEMENTS MUST BE SHOWN ON GRADING PLAN.
3. PROVIDE MAIN FLOOR AND BASEMENT ELEVATIONS.
4. SPECIFY PROPOSED GRADES ON SWALES.
5. IDENTIFY PROPOSED LOCATION AND DIMENSION OF SEPTIC TILE BED AND RESERVE BED AREAS,
6. PROVIDE REGISTERED PLAN NUMBER.
7. MAXIMUM DRIVEWAY GRADE TO BE 6%.
8. SHOW SERVICE LATERAL INVERT ELEVATION AT STREET LINE AND CURB STOP LOCATION (WHEN APPLICABLE)
9. SHOW ALL UTILITY INSTALLATIONS IN BOULEVARD.
10. DRAINAGE SWALES TO BE ON PROPERTY LINE. SET SWALE ENTIRELY WITHIN LOT IF ABUTTING PROPERTY NOT UNDERGOING DEVELOPMENT.



TYPICAL LEGEND FOR LOT GRADING PLAN



| NO. | REVISIONS | DATE | APR'D |
|-----|-----------|------|-------|
| | | | |
| | | | |
| | | | |

SCALE: N.T.S.
 DATE: NOV. 2021
ERIN SD.
800

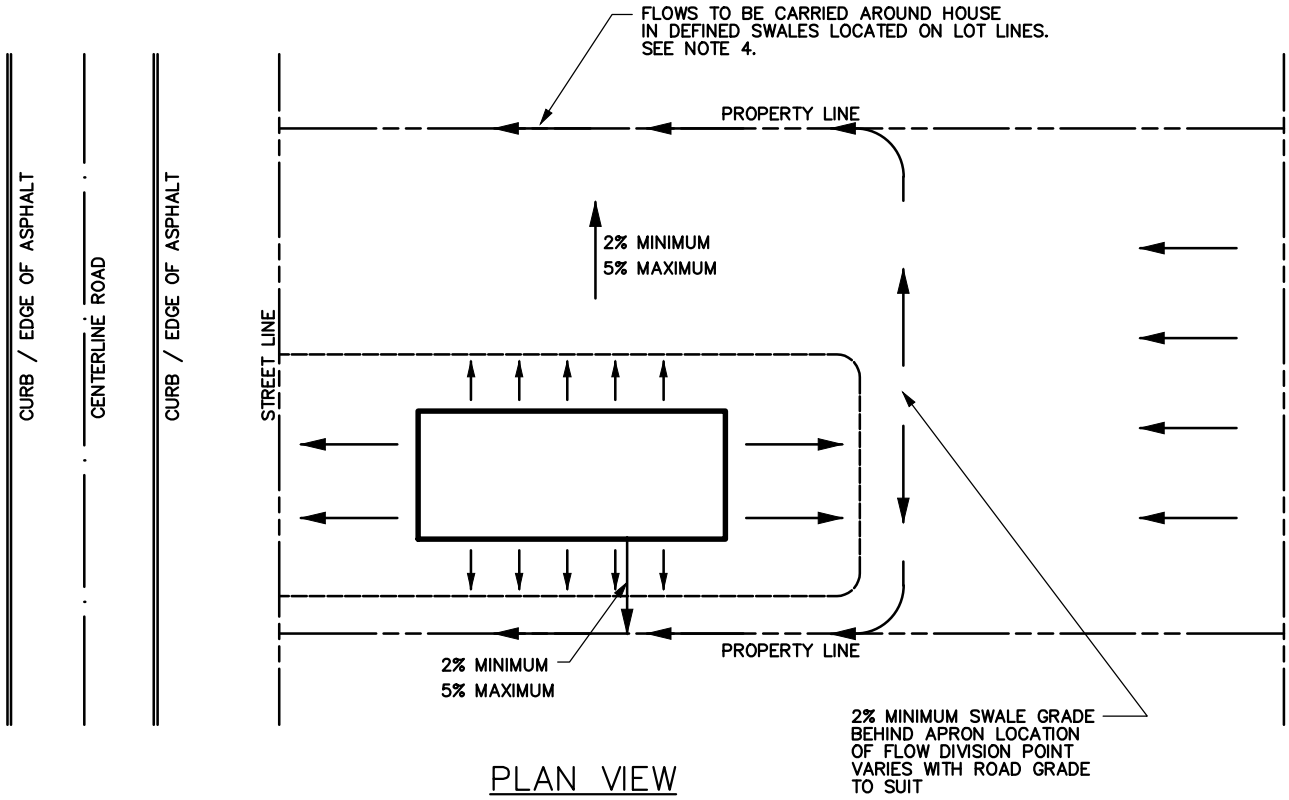

PLAN VIEW

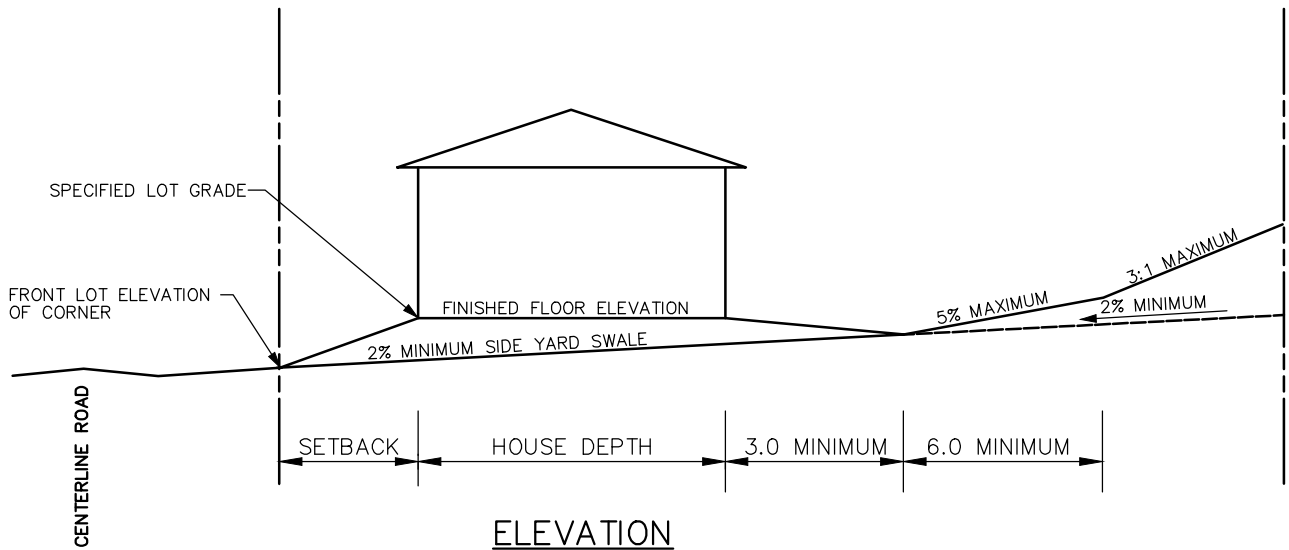

ELEVATION

NOTES:

1. SPECIFIED LOT GRADE SHALL BE MINIMUM 0.30m ABOVE HIGHEST FRONT LOT CORNER.
2. DRIVEWAYS ARE NOT TO BE USED AS AN OUTLET FOR ANY SIDEYARD SWALE.
3. ALL DIMENSIONS ARE IN METERS UNLESS OTHERWISE SPECIFIED.
4. DRAINAGE SWALES TO BE ON PROPERTY LINE. SET SWALE ENTIRELY WITHIN LOT IF ABUTTING PROPERTY NOT UNDERGOING DEVELOPMENT.



FRONT LOT DRAINAGE



METRIC
ALL DIMENSIONS ARE
IN METRES UNLESS
OTHERWISE SHOWN

| NO. | REVISIONS | DATE | APR'D |
|-----|-----------|------|-------|
| | | | |
| | | | |
| | | | |

SCALE: N.T.S.
DATE: NOV. 2021

ERIN SD.
801

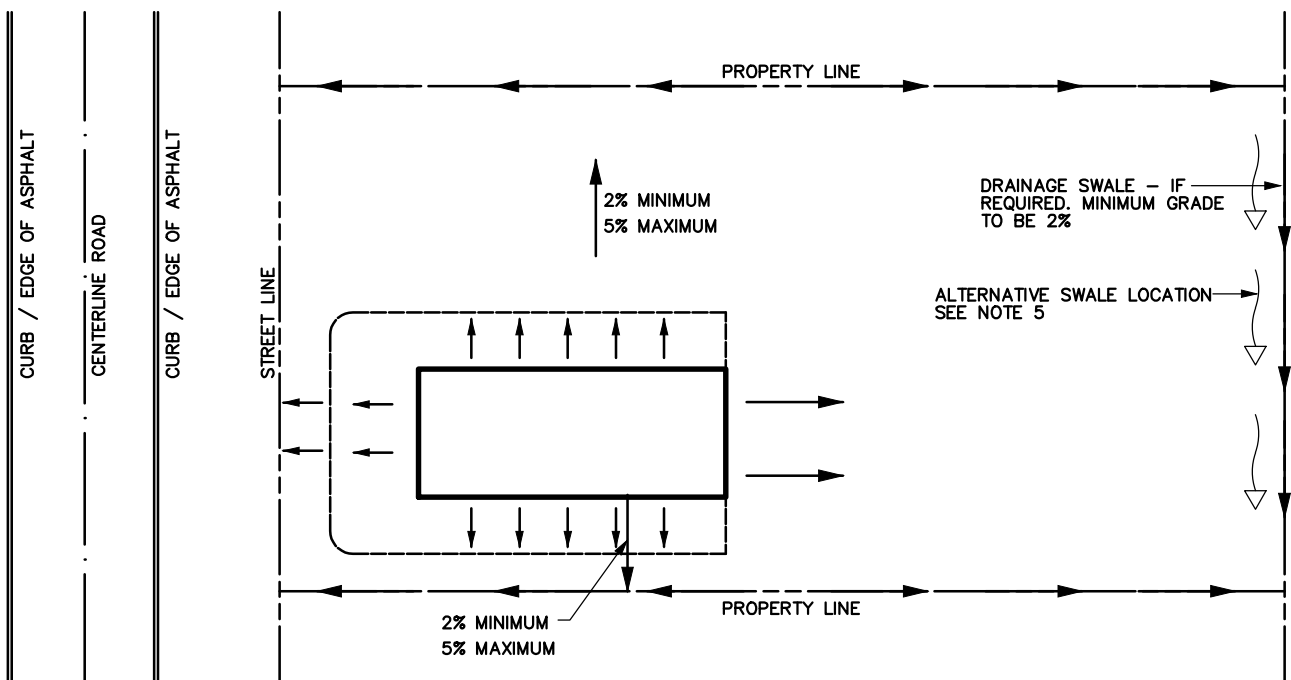

PLAN VIEW

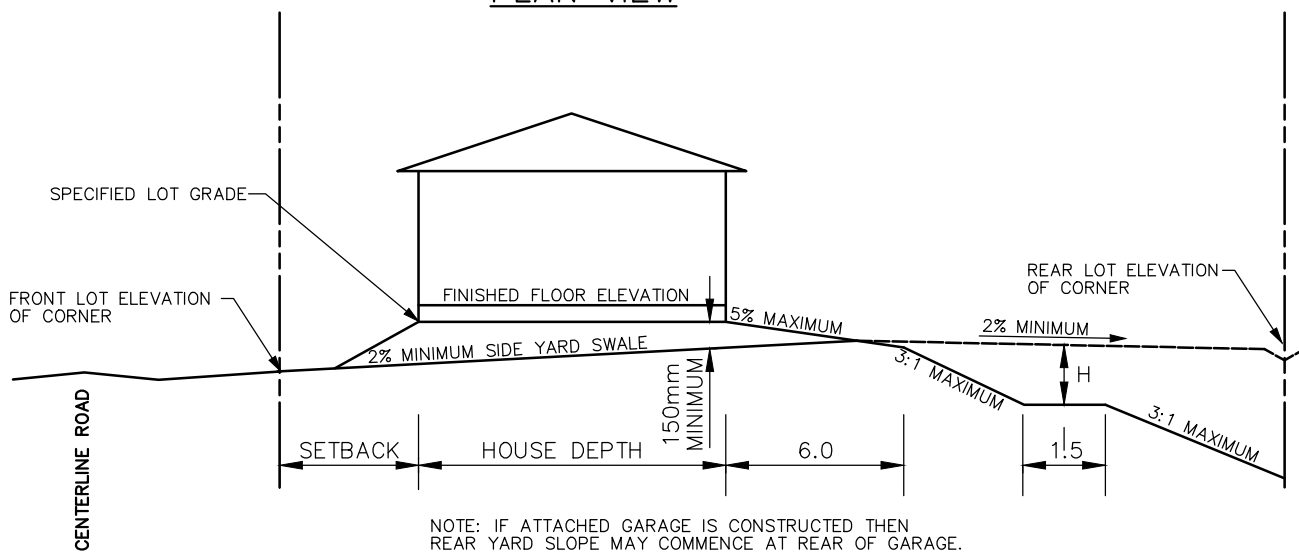

NOTE: IF ATTACHED GARAGE IS CONSTRUCTED THEN REAR YARD SLOPE MAY COMMENCE AT REAR OF GARAGE.

ELEVATION

NOTES:

1. SPECIFIED LOT GRADE SHALL BE MINIMUM 0.30m ABOVE HIGHEST FRONT LOT CORNER.
2. DRIVEWAYS ARE NOT TO BE USED AS AN OUTLET FOR ANY SIDEYARD SWALE.
3. 'H' DIMENSION TO BE 1.8m MAXIMUM, UNLESS UNDISTURBED EXISTING SLOPE. TERRACE CAN BE ELIMINATED ON SLOPES OF 4:1 OR LESS.
4. ALL DIMENSIONS ARE IN METERS UNLESS OTHERWISE SPECIFIED.
5. DRAINAGE SWALES TO BE ON PROPERTY LINE. SET SWALE ENTIRELY WITHIN LOT IF ABUTTING PROPERTY NOT UNDERGOING DEVELOPMENT.



REAR LOT DRAINAGE



| NO. | REVISIONS | DATE | APR'D |
|-----|-----------|------|-------|
| | | | |
| | | | |
| | | | |

SCALE: N.T.S.
 DATE: NOV. 2021
ERIN SD.
802

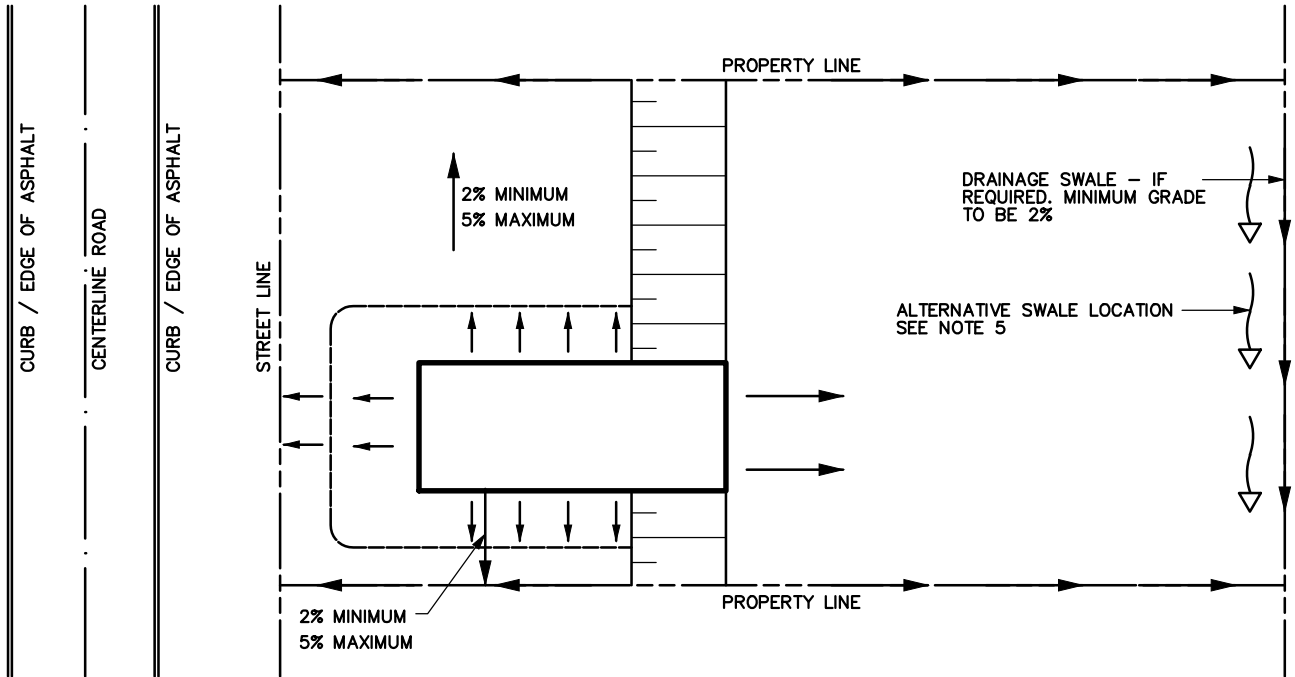

PLAN VIEW

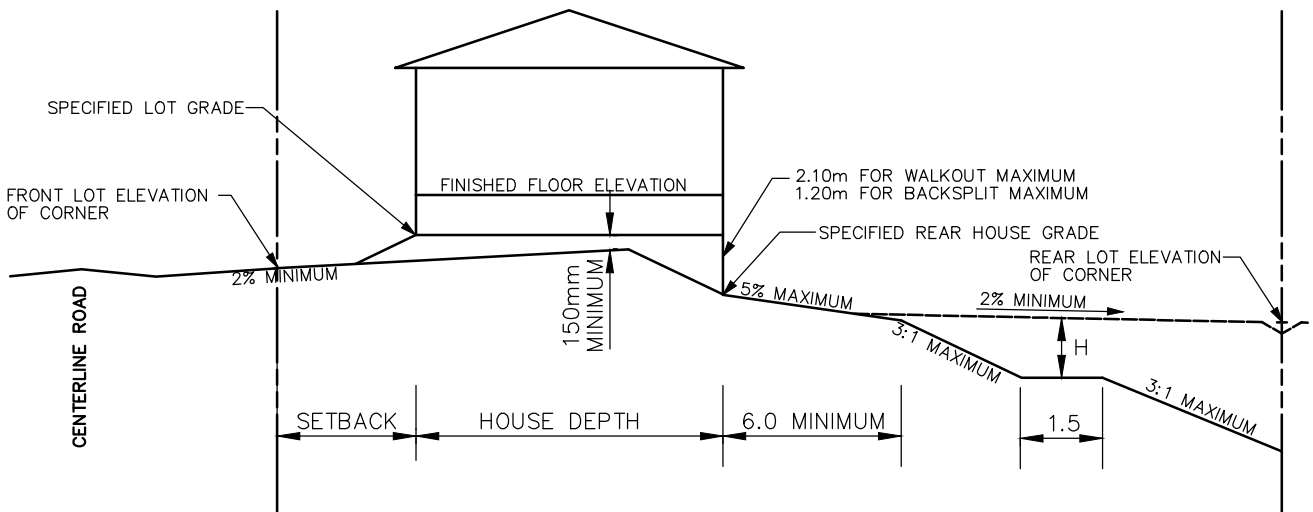

ELEVATION

NOTES:

1. SPECIFIED LOT GRADE SHALL BE MINIMUM 0.30m ABOVE HIGHEST FRONT LOT CORNER.
2. 'H' DIMENSION TO BE 1.8m MAXIMUM, UNLESS UNDISTURBED EXISTING SLOPE. TERRACE CAN BE ELIMINATED ON SLOPES OF 4:1 OR LESS.
3. REAR HOUSE GRADE MUST ALSO BE SPECIFIED ON LOT GRADING PLANS WHEN THIS HOUSE TYPE IS PROPOSED.
4. ALL DIMENSIONS ARE IN METERS UNLESS OTHERWISE SPECIFIED.
5. DRAINAGE SWALES TO BE ON PROPERTY LINE. SET SWALE ENTIRELY WITHIN LOT IF ABUTTING PROPERTY NOT UNDERGOING DEVELOPMENT.



REAR LOT DRAINAGE FOR WALKOUT OR BACK SPLIT HOUSE



| NO. | REVISIONS | DATE | APR'D |
|-----|-----------|------|-------|
| | | | |
| | | | |
| | | | |

SCALE: N.T.S.
DATE: NOV. 2021
ERIN SD.
803

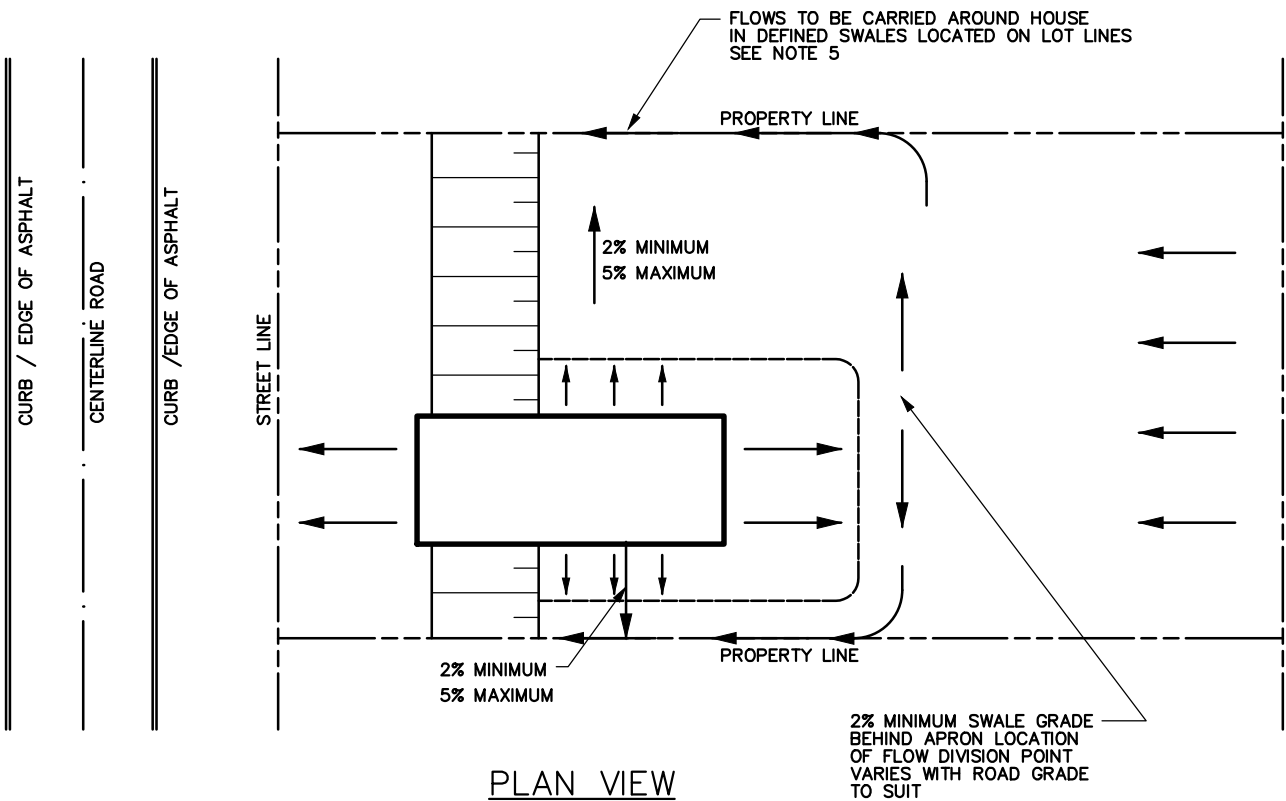

PLAN VIEW

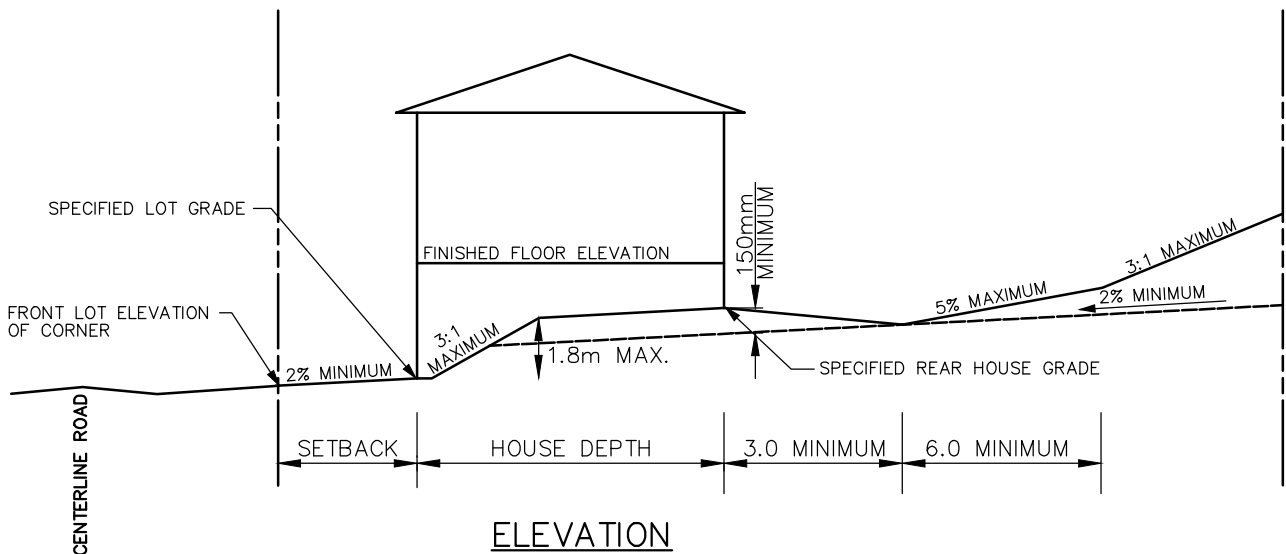

ELEVATION

NOTES:

1. SPECIFIED LOT GRADE SHALL BE MINIMUM 0.30m ABOVE HIGHEST FRONT LOT CORNER.
2. DRIVEWAYS ARE NOT TO BE USED AS AN OUTLET FOR ANY SIDEYARD SWALE.
3. REAR HOUSE GRADE MUST BE SPECIFIED ON LOT GRADING PLANS WHEN THIS HOUSE TYPE IS PROPOSED.
4. ALL DIMENSIONS ARE IN METERS UNLESS OTHERWISE SPECIFIED.
5. DRAINAGE SWALES TO BE ON PROPERTY LINE. SET SWALE ENTIRELY WITHIN LOT IF ABUTTING PROPERTY NOT UNDERGOING DEVELOPMENT.



FRONT LOT DRAINAGE FOR FRONT SPLIT HOUSE



| NO. | REVISIONS | DATE | APR'D |
|-----|-----------|------|-------|
| | | | |
| | | | |
| | | | |

SCALE: N.T.S.
 DATE: NOV. 2021
ERIN SD.
804

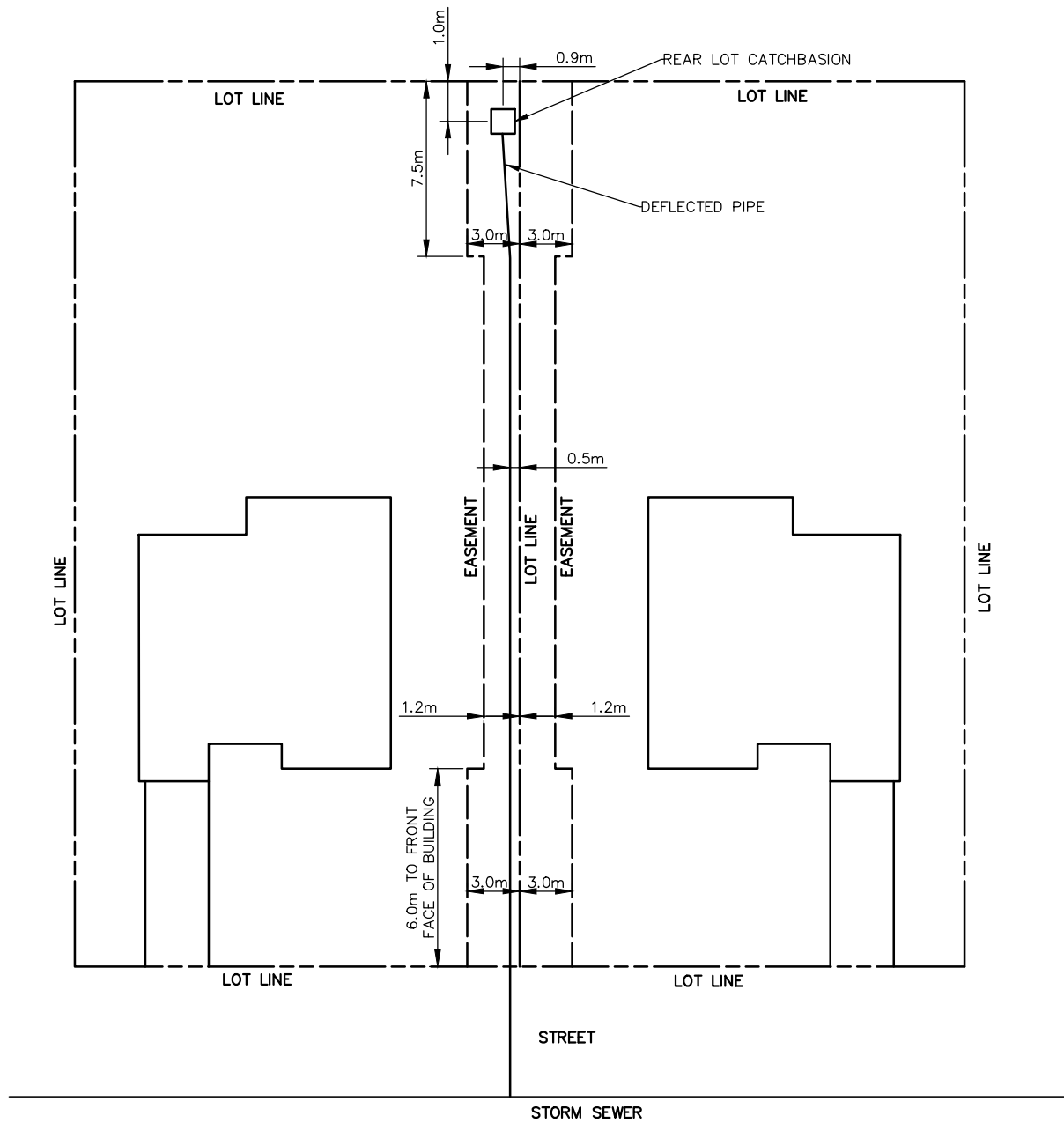

TOWN OF
ERIN

TYPICAL RLCB DRAINAGE
EASEMENT



METRIC
ALL DIMENSIONS ARE
IN METRES UNLESS
OTHERWISE SHOWN

| NO. | REVISIONS | DATE | APR'D |
|-----|-----------|------|-------|
| | | | |
| | | | |
| | | | |

SCALE: N.T.S.
DATE: NOV. 2021

ERIN SD.
805

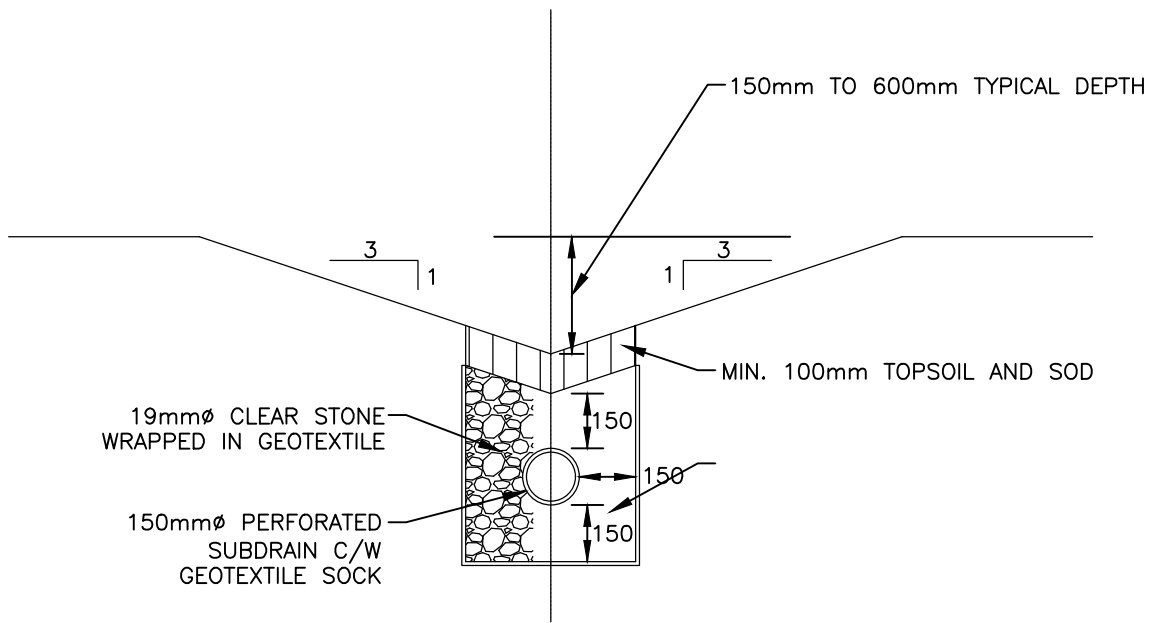

SUBDRAIN TYPE "A"

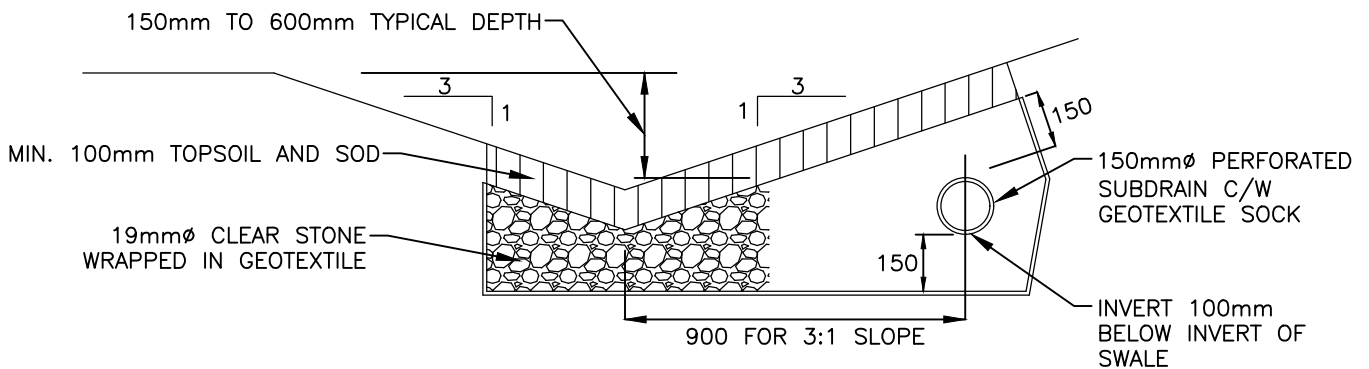

SUBDRAIN TYPE "B"

(TYPE "B" SUBDRAIN TO BE USED WHERE
OUTFALL ELEVATION PREVENTS DEEPER
INSTALLATION OF TYPE "A" SUBDRAIN)



| NO. | REVISIONS | DATE | APR'D |
|-----|-----------|------|-------|
| | | | |
| | | | |
| | | | |

TWO HEAVY-DUTY GAUGE 'T' BARS PER TREE, 2400mm LONG, LOCATED AWAY FROM ALL BRANCHES, ONE ON THE SIDE OF PREVAILING WIND, THE OTHER ON THE OPPOSITE SIDE.
DO NOT DRIVE STAKES THROUGH ROOT BALL.

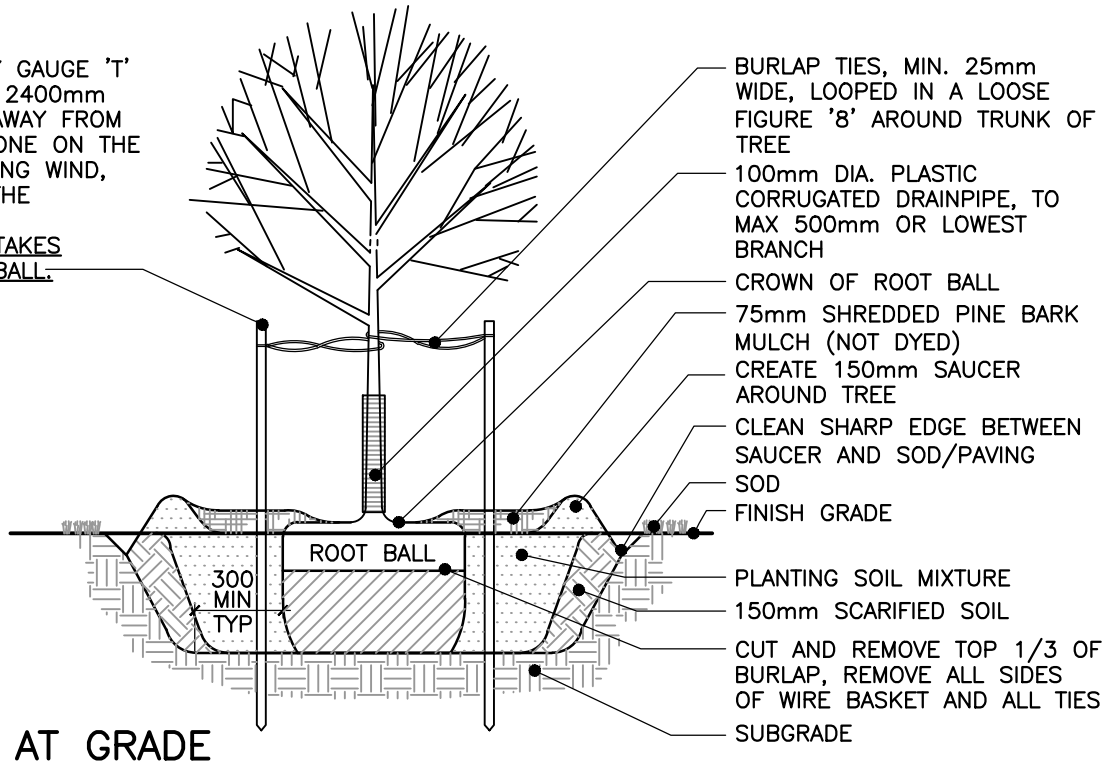

AT GRADE

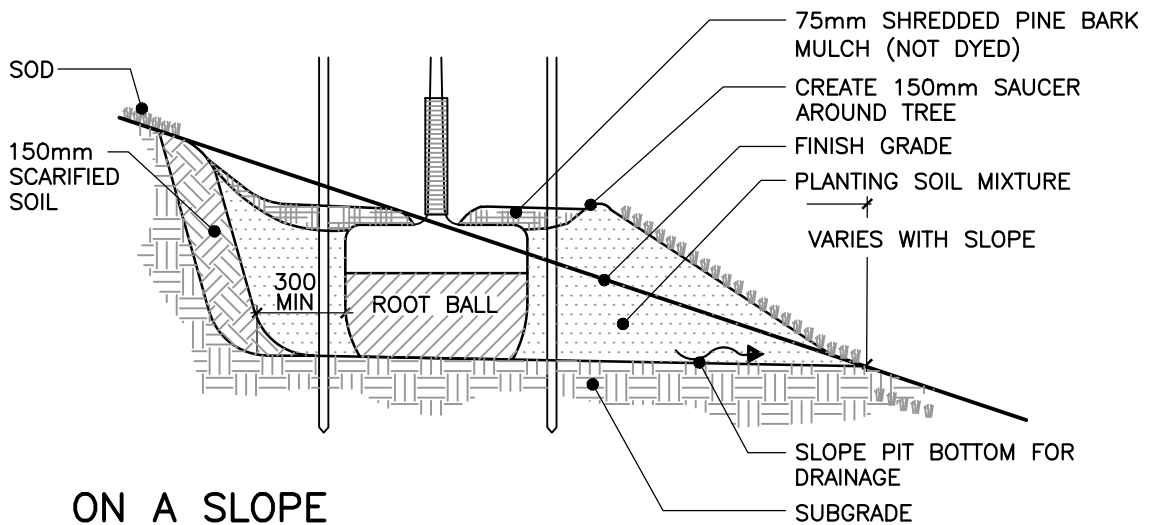

ON A SLOPE

NOTES

1. DO NOT ALLOW AIR POCKETS WHEN BACKFILLING.
2. POSITION CROWN OF ROOT BALL 50mm ABOVE FINISH GRADE TO ALLOW FOR SETTLING.
3. DO CORRECTIVE PRUNING TO RETAIN NATURAL FORM OF TREE AS DIRECTED BY THE LANDSCAPE ARCHITECT.
4. FOR TREES PLANTED WITHIN PLANTING OR SHRUB BEDS, DELETE SAUCER AROUND BASE OF TREE.
5. ALL DIMENSIONS ARE IN MILLIMETRES.
6. NO TREE PITS SHALL BE LEFT OPEN OVERNIGHT.
7. TREE GUARD REQUIRED FOR PLANTINGS IN URBAN AREAS.



DECIDUOUS TREE PLANTING



| NO. | REVISIONS | DATE | APR'D |
|-----|-----------|------|-------|
| | | | |
| | | | |
| | | | |

SCALE: N.T.S.
 DATE: NOV. 2021
ERIN SD.
901

NOTES

1. DO NOT ALLOW AIR POCKETS WHEN BACKFILLING.
2. POSITION CROWN OF ROOT BALL 50mm ABOVE FINISH GRADE TO ALLOW FOR SETTLING.
3. FOR TREES PLANTED WITHIN PLANTING OR SHRUB BEDS, DELETE SAUCER AROUND BASE OF TREE.
4. ALL DIMENSIONS IN MILLIMETRES.
5. NO TREE PITS SHALL BE LEFT OPEN OVERNIGHT.

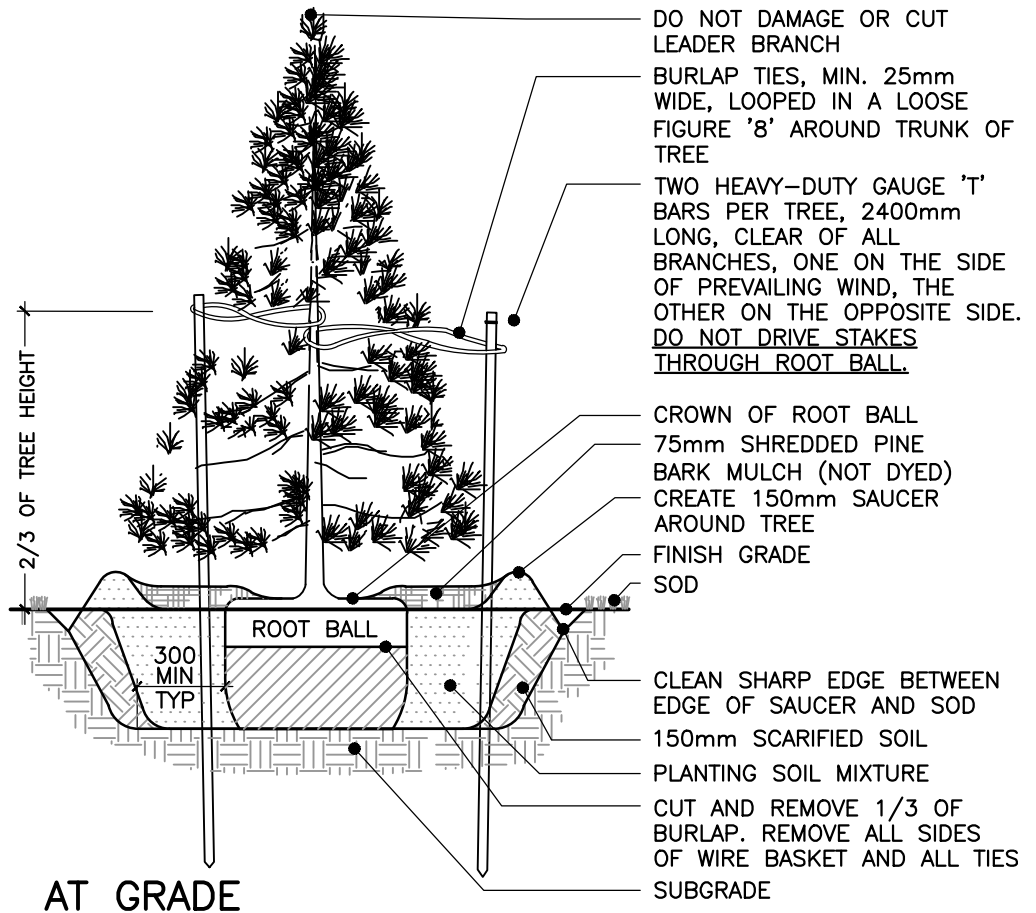

AT GRADE

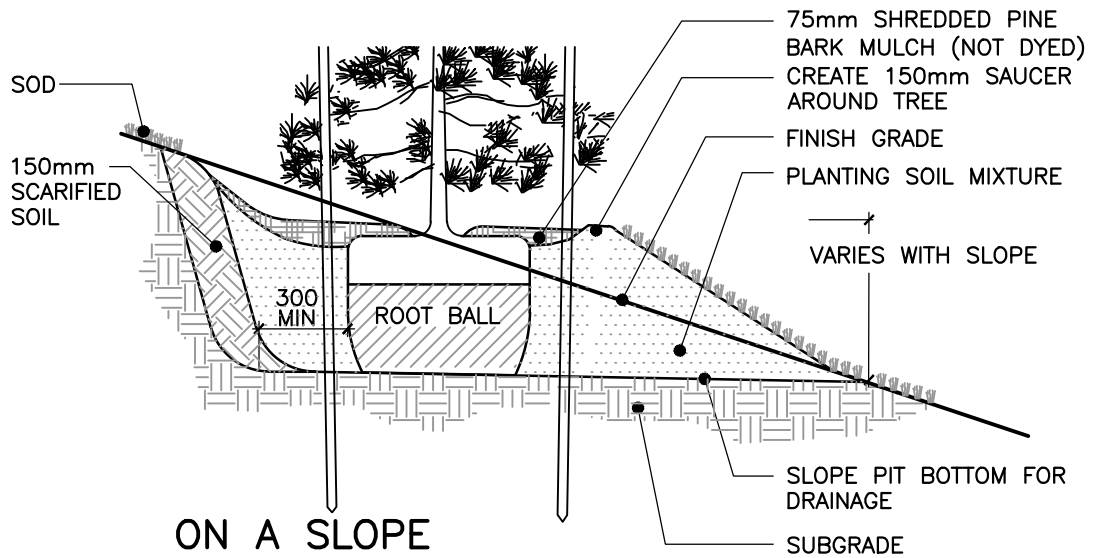

ON A SLOPE



CONIFEROUS TREE PLANTING



METRIC
ALL DIMENSIONS ARE
IN METRES UNLESS
OTHERWISE SHOWN

| NO. | REVISIONS | DATE | APR'D |
|-----|-----------|------|-------|
| | | | |
| | | | |
| | | | |

SCALE: N.T.S.
DATE: NOV. 2021

**ERIN SD.
902**

Appendix B: Approved Seed Mix Designs



TABLE 1
Permanent Seed Mixes and Seed Certificate Analysis Values

| Permanent Seed Mix | Grade Name | Minimum Seed Germination % | Minimum Seed Purity % | Maximum Weed Seed % | Seed Mix % | Seed Species Composition % |
|---|--|-----------------------------------|------------------------------|----------------------------|-------------------|-----------------------------------|
| Standard Roadside Mix | Canada #1 Lawn Grass Seed Mixture | 70 | 85 | 0.5 | | |
| Creeping Red Fescue: <i>Festuca rubra</i> | | | | | 50 | 50 to 60 |
| Kentucky Bluegrass: <i>Poa pratensis</i> | | | | | 10 | 25 to 30 |
| Perennial Ryegrass: <i>Lolium perenne</i> | | | | | 35 | 12 to 18 |
| White Clover: <i>Trifolium repens</i> | | | | | 5 | 2 to 4 |
| | | | | | | |
| Crown Vetch Mix | Common #1 Forage Mixture | 75 | N/A | 3.0 | | |
| Creeping Red Fescue: <i>Festuca rubra</i> | | | | | 66 | 62 to 70 |
| Crown Vetch: <i>Coronilla varia</i> inoculated seed | | | | | 34 | 30 to 38 |
| | | | | | | |
| Birdsfoot Trefoil Mix | Common #1 Forage Mixture | 75 | N/A | 3.0 | | |
| Creeping Red Fescue: <i>Festuca rubra</i> | | | | | 66 | 62 to 70 |

Continues on Next Page

| Permanent Seed Mix | Grade Name | Minimum Seed Germination % | Minimum Seed Purity % | Maximum Weed Seed % | Seed Mix % | Seed Species Composition % |
|---------------------------|-------------------|-----------------------------------|------------------------------|----------------------------|-------------------|-----------------------------------|
|---------------------------|-------------------|-----------------------------------|------------------------------|----------------------------|-------------------|-----------------------------------|

Continues From Previous Page

| | | | | | | |
|---|---------------------------------------|-----------|------------|------------|----|----------|
| Birdsfoot Trefoil 'Leo': <i>Lotus corniculatus</i> 'Leo inoculated seed | | | | | 34 | 30 to 38 |
| Salt Tolerant Mix | Canada #1 Ground Cover Mixture | 70 | 85 | 3.0 | | |
| Tall Fescue: <i>Festuca arundinacea</i> | | | | | 25 | 20 to 30 |
| Fults Alkali Grass: <i>Puccinellia distans</i> | | | | | 20 | 15 to 25 |
| Creeping Red Fescue: <i>Festuca rubra</i> | | | | | 25 | 15 to 25 |
| Perennial Ryegrass: <i>Lolium perenne</i> | | | | | 20 | 15 to 25 |
| Hard Fescue: <i>Festuca trachyphylla</i> | | | | | 10 | 10 to 15 |
| Lowland Mix | Common #1 Forage Mixture | 75 | N/A | 3.0 | | |
| Creeping Red Fescue: <i>Festuca rubra</i> | | | | | 35 | 40 to 50 |
| Brome Grass: <i>Bromus nerris</i> | | | | | 25 | 20 to 30 |
| Kentucky Bluegrass: <i>Poa pratensis</i> | | | | | 10 | 10 to 20 |

Continues on Next Page

| Permanent Seed Mix | Grade Name | Minimum Seed Germination % | Minimum Seed Purity % | Maximum Weed Seed % | Seed Mix % | Seed Species Composition % |
|---------------------------|-------------------|-----------------------------------|------------------------------|----------------------------|-------------------|-----------------------------------|
|---------------------------|-------------------|-----------------------------------|------------------------------|----------------------------|-------------------|-----------------------------------|

Continues From Previous Page

| | | | | | | |
|--|---------------------------------|-----------|------------|------------|----|----------|
| Birdsfoot Trefoil 'Leo': <i>Lotus corniculatus</i> 'Leo' inoculated seed | | | | | 5 | 3 to 7 |
| White Clover: <i>Trifolium repens</i> | | | | | 5 | 3 to 7 |
| Perennial Ryegrass: <i>Lolium perenne</i> | | | | | 20 | 3 to 7 |
| | | | | | | |
| Acidic Soil Mix | Common #1 Forage Mixture | 75 | N/A | 3.0 | | |
| Birdsfoot Trefoil 'Leo', <i>Lotus corniculatus</i> 'Leo' inoculated seed | | | | | 30 | 30 to 40 |
| Red Top: <i>Agrostis gigantea</i> | | | | | 10 | 20 to 30 |
| Tall Fescue: <i>Festuca arundinacea</i> | | | | | 15 | 15 to 20 |
| Creeping Red Fescue: <i>Festuca rubra</i> | | | | | 30 | 7 to 12 |
| Hard Fescue: <i>Festuca trachyphylla</i> | | | | | 5 | 3 to 7 |
| Alsike Clover: <i>Trifolium hybridum</i> | | | | | 5 | 3 to 7 |
| Red Clover: <i>Trifolium pratense</i> | | | | | 5 | 3 to 7 |

Appendix C: Acceptable Trees



NEW TREE PLANTING SPECIES LIST

| Family Name | Botanical Name | Common Name | STREETS | PARKS or Large Street Treelawn | SWMP or other Naturalized area | SIZE | Hydro Approved (under) | Suggested Frequency of Planting |
|--|---|---------------------------------|---------|--------------------------------|--------------------------------|------|------------------------|---------------------------------|
| <i>Pinaceae</i> | <i>Abies balsamea</i> | fir, balsam | | X | X | L | | Frequently |
| <i>Pinaceae</i> | <i>Abies concolor</i> | fir, white | | X | | L | | Moderately |
| <i>Sapindaceae</i> (<i>Aceraceae</i>) | <i>Acer campestre</i> | maple, hedge | X | X | | M | | Sparingly |
| <i>Sapindaceae</i> (<i>Aceraceae</i>) | <i>Acer x freemanii</i> 'Celebration' | maple, Celebration | X | X | | M | | Sparingly |
| <i>Sapindaceae</i> (<i>Aceraceae</i>) | <i>Acer ginnala</i> | maple, Amur | X | X | | S | X | Sparingly |
| <i>Sapindaceae</i> (<i>Aceraceae</i>) | <i>Acer griseum</i> | maple, Paperbark | | X | | S | | Sparingly |
| <i>Sapindaceae</i> (<i>Aceraceae</i>) | <i>Acer nigrum</i> | maple, black | | X | | L | | Sparingly |
| <i>Sapindaceae</i> (<i>Aceraceae</i>) | <i>Acer nigrum</i> 'Green Column' | maple, green column | X | | | L | | Sparingly |
| <i>Sapindaceae</i> (<i>Aceraceae</i>) | <i>Acer platanoides</i> 'columnar' | maple, Columnar | X | | | M | | Sparingly |
| <i>Sapindaceae</i> (<i>Aceraceae</i>) | <i>Acer platanoides</i> 'Crimson King' | maple, Crimson King | X | | | M | | Sparingly |
| <i>Sapindaceae</i> (<i>Aceraceae</i>) | <i>Acer platanoides</i> 'Deborah' | maple, Deborah | X | | | M | | Sparingly |
| <i>Sapindaceae</i> (<i>Aceraceae</i>) | <i>Acer platanoides</i> 'Drummondii' | maple, Variegated | | X | | M | | Sparingly |
| <i>Sapindaceae</i> (<i>Aceraceae</i>) | <i>Acer platanoides</i> 'Globosum' | maple, Globe | X | X | | S | X | Sparingly |
| <i>Sapindaceae</i> (<i>Aceraceae</i>) | <i>Acer pseudoplatanus</i> | maple, Sycamore | | X | | L | | Sparingly |
| <i>Sapindaceae</i> (<i>Aceraceae</i>) | <i>Acer rubrum</i> | maple, red | | X | X | L | | Sparingly |
| <i>Sapindaceae</i> (<i>Aceraceae</i>) | <i>Acer saccharinum</i> | maple, silver 'cutleaf' | X | X | | M | | Sparingly |
| <i>Sapindaceae</i> (<i>Aceraceae</i>) | <i>Acer saccharum</i> | maple, sugar | X | X | X | L | | Sparingly |
| <i>Sapindaceae</i> (<i>Aceraceae</i>) | <i>Acer tataricum</i> | maple, Tatarian | | X | | S | | Sparingly |
| <i>Sapindaceae</i> (<i>Aceraceae</i>) | <i>Acer x freemanii</i> | maple, Freemanii | X | | | L | | Sparingly |
| <i>Sapindaceae</i> (<i>Aceraceae</i>) | <i>Acer x freemanii</i> 'Autumn Blaze' | maple, Freemanii 'autumn blaze' | X | | | L | | Sparingly |
| <i>Sapindaceae</i> (<i>Aceraceae</i>) | <i>Acer x freemanii</i> 'Autumn Fantasy' | maple, Autumn Fantasy | X | | | L | | Sparingly |
| <i>Sapindaceae</i> (<i>Aceraceae</i>) | <i>Acer x freemanii</i> 'Firefall' | maple, Firefall | X | | | L | | Sparingly |
| <i>Sapindaceae</i> (<i>Aceraceae</i>) | <i>Acer x freemanii</i> 'Marmo' | maple, Marmo | X | | | L | | Sparingly |

| Family Name | Botanical Name | Common Name | STREETS | PARKS or Large Street Treelawn | SWMP or other Naturalized area | SIZE | Hydro Approved (under) | Suggested Frequency of Planting |
|--|--|---------------------------------|---------|--------------------------------|--------------------------------|------|------------------------|---------------------------------|
| <i>Sapindaceae</i> (<i>Aceraceae</i>) | <i>Acer x freemanii</i> 'Sienna' | maple, Sienna Glen | X | | | L | | Sparingly |
| <i>Sapindaceae</i> (<i>Hippocastana ceae</i>) | <i>Aesculus carnea</i> 'Briotii' | chestnut, Ruby-Red Horse | | X | | S | | Sparingly |
| <i>Sapindaceae</i> (<i>Hippocastana ceae</i>) | <i>Aesculus flava</i> | buckeye, yellow | | X | | M | | Sparingly |
| <i>Sapindaceae</i> (<i>Hippocastana ceae</i>) | <i>Aesculus glabra</i> | buckeye, Ohio | X | X | X | M | | Sparingly |
| <i>Sapindaceae</i> (<i>Hippocastana ceae</i>) | <i>Aesculus hippocastanum</i> | horse chestnut | | X | | L | | Sparingly |
| <i>Sapindaceae</i> (<i>Hippocastana ceae</i>) | <i>Aesculus x carnea</i> 'Fort McNair' | horse Chestnut, Fort McNair | | X | | M | | Sparingly |
| <i>Betulaceae</i> | <i>Alnus incana</i> | alder, gray (speckled) | | | | L | | Moderately |
| <i>Betulaceae</i> | <i>Alnus glutinosa</i> | alder, European | | X | | | | Sparingly |
| <i>Rosaceae</i> | <i>Amelanchier canadensis</i> | serviceberry | X | X | X | S | X | Moderately |
| <i>Rosaceae</i> | <i>Amelanchier canadensis</i> 'ballerina' | serviceberry, ballerina | X | | | S | X | Moderately |
| <i>Rosaceae</i> | <i>Amelanchier canadensis</i> 'rainbow pillar' | serviceberry, rainbow pillar | X | | | S | X | Moderately |
| <i>Rosaceae</i> | <i>Amelanchier grandiflora</i> 'autumn brilliance' | serviceberry, autumn brilliance | X | | | S | X | Moderately |
| <i>Rosaceae</i> | <i>Amelanchier grandiflora</i> 'cumulus' | serviceberry, cumulus | X | | | S | X | Moderately |
| <i>Rosaceae</i> | <i>Amelanchier grandiflora</i> 'princess diana' | serviceberry, princess diana | X | | | S | X | Moderately |
| <i>Rosaceae</i> | <i>Amelanchier grandiflora</i> 'robin hill' | serviceberry, robin hill | X | | | S | X | Moderately |
| <i>Rosaceae</i> | <i>Amelanchier laevis</i> 'spring flurry' | serviceberry, spring flurry | X | | | S | X | Moderately |
| <i>Annonaceae</i> | <i>Asminia triloba</i> | Pawpaw | | | X | S-M | | Sparingly |
| <i>Betulaceae</i> | <i>Betula alleghaniensis</i> | birch, yellow | | X | X | L | | Sparingly |
| <i>Betulaceae</i> | <i>Betula lenta</i> | birch, cherry (sweet) | | X | | | | Sparingly |
| <i>Betulaceae</i> | <i>Betula nigra</i> | birch, River | | X | | M | | Moderately |

| Family Name | Botanical Name | Common Name | STREETS | PARKS or Large Street Treelawn | SWMP or other Naturalized area | SIZE | Hydro Approved (under) | Suggested Frequency of Planting |
|--------------------------|---|---------------------------------|---------|--------------------------------|--------------------------------|------|------------------------|---------------------------------|
| <i>Betulaceae</i> | <i>Betula nigra 'Cully'</i> | birch, Heritage | X | X | | M | | Sparingly |
| <i>Betulaceae</i> | <i>Betula papyrifera</i> | birch, white (paper) | | X | | M | | Sparingly |
| <i>Betulaceae</i> | <i>Betula papyrifera 'Renci' clump</i> | birch, Renaissance Reflection | | X | | L | | Sparingly |
| <i>Betulaceae</i> | <i>Carpinus betulus 'Fastigiata'</i> | hornbeam, European (fastigiata) | X | X | | M | | Moderately |
| <i>Betulaceae</i> | <i>Carpinus caroliniana</i> | hornbeam, American (blue beech) | | X | X | S | | Moderately |
| <i>Juglandaceae</i> | <i>Carya cordiformis</i> | hickory, bitternut | | X | X | L | | Frequently |
| <i>Juglandaceae</i> | <i>Carya illinoensis</i> | Pecan | | X | | | | Sparingly |
| <i>Juglandaceae</i> | <i>Carya laciniosa</i> | hickory, shellbark | | X | | L | | Frequently |
| <i>Juglandaceae</i> | <i>Carya ovata</i> | hickory, shagbark | | X | X | L | | Frequently |
| <i>Fagaceae</i> | <i>Castanea sativa</i> | chestnut, Spanish | | X | | L | | Moderately |
| <i>Fagaceae</i> | <i>Castanea mollissima</i> | chestnut, Chinese | | X | | L | | Moderately |
| <i>Bignoniaceae</i> | <i>Catalpa speciosa</i> | northern catalpa | | X | | L | | Moderately |
| <i>Pinaceae</i> | <i>Cedrus deodora</i> | Deodar cedar | | X | | | | Sparingly |
| <i>Ulmaceae</i> | <i>Celtis occidentalis</i> | hackberry | X | | | L | | Moderately |
| <i>Ulmaceae</i> | <i>Celtis occidentalis 'Chicagoland'</i> | hackberry, Chicagoland | X | | | L | | Moderately |
| <i>Ulmaceae</i> | <i>Celtis occidentalis 'Prairie sentinel'</i> | hackberry, Prairie Sentinel | X | | | L | | Moderately |
| <i>Cercidiphyllaceae</i> | <i>Cercidiphyllum japonicum</i> | Katsura Tree | | X | | L | | Frequently |
| <i>Fabaceae</i> | <i>Cercis canadensis</i> | redbud, Eastern | | X | X | S | X | Moderately |
| <i>Cupressaceae</i> | <i>Chamaecyparis lawsonia</i> | false cypress, lawson | | X | | L | | Moderately |
| <i>Cornaceae</i> | <i>Cornus alternifolia</i> | dogwood, Pagoda | | X | X | S | X | Frequently |
| <i>Cornaceae</i> | <i>Cornus racemosa</i> | dogwood, gray | | x | | S | X | Frequently |
| <i>Betulaceae</i> | <i>Corylus colurna</i> | hazel, Turkish (filbert) | | X | | M | | Frequently |
| <i>Rosaceae</i> | <i>Crataegus crusgalli 'inermis'</i> | hawthorn, thornless cockspur | | X | | S | | Frequently |
| <i>Elaeagnaceae</i> | <i>Elaeagnus angustifolia</i> | olive, Russian | X | | | M | | Moderately |
| <i>Eucommiaceae</i> | <i>Eucommia ulmoides</i> | Hardy Rubber Tree | X | X | | M | | Frequently |
| <i>Fagaceae</i> | <i>Fagus grandifolia</i> | American beech | | X | X | L | | Moderately |
| <i>Fagaceae</i> | <i>Fagus sylvatica</i> | European beech | | X | | L | | Moderately |

| Family Name | Botanical Name | Common Name | STREETS | PARKS or Large Street Treelawn | SWMP or other Naturalized area | SIZE | Hydro Approved (under) | Suggested Frequency of Planting |
|-----------------------|--|------------------------------------|---------|--------------------------------|--------------------------------|------|------------------------|---------------------------------|
| <i>Ginkgoaceae</i> | <i>Ginkgo biloba</i> | gingko, (maidenhair) | X | X | | L | | Frequently |
| <i>Ginkgoaceae</i> | <i>Ginkgo biloba</i> 'Umbrella' | Globe Gingko | X | | | S | X | Frequently |
| <i>Fabaceae</i> | <i>Gleditsia triacanthos</i> 'inermis' | honeylocust | X | | | L | | Moderately |
| <i>Fabaceae</i> | <i>Gymnocladus dioicus</i> | Kentucky coffeetree | X | X | X | L | | Frequently |
| <i>Aquifoliaceae</i> | <i>Ilex opaca</i> | American holly | | X | | | | Sparingly |
| <i>Juglandaceae</i> | <i>Juglans cinerea</i> | butternut | | X | X | L | | Moderately |
| <i>Juglandaceae</i> | <i>Juglans nigra</i> | black walnut | | X | X | L | | Moderately |
| <i>Cupressaceae</i> | <i>Juniperus virginiana</i> | eastern red cedar | | X | | M | | Moderately |
| <i>Pinaceae</i> | <i>Larix decidua</i> | European larch | | X | | L | | Moderately |
| <i>Pinaceae</i> | <i>Larix kaempferi</i> | Japanese larch | | X | | L | | Moderately |
| <i>Pinaceae</i> | <i>Larix laricina</i> | tamarack | | X | x | L | | Moderately |
| <i>Hamamelidaceae</i> | <i>Liquidambar styraciflua</i> | sweetgum | | X | | L | | Moderately |
| <i>Magnoliaceae</i> | <i>Liriodendron tulipifera</i> | tulip-tree | X | X | X | L | | Frequently |
| <i>Magnoliaceae</i> | <i>Liriodendron tulipifera</i> 'Aureomarginatum' | Variegated Tulip Tree | | X | | L | | Moderately |
| <i>Magnoliaceae</i> | <i>Liriodendron tulipifera</i> 'Emerald city' | Emerald City Tulip Tree | | X | | L | | Moderately |
| <i>Magnoliaceae</i> | <i>Liriodendron tulipifera</i> 'Fastigiata' | Columnar Tulip Tree | X | X | | L | | Moderately |
| <i>Fabaceae</i> | <i>Maackia amurensis</i> | Amur Maackia | | X | | M | | Moderately |
| <i>Moraceae</i> | <i>Maclura pomifera</i> | Osage-orange | | X | X | M | | Sparingly |
| <i>Magnoliaceae</i> | <i>Magnolia acuminata</i> | Cucumber tree | | X | X | M | | Moderately |
| <i>Rosaceae</i> | <i>Malus spp.</i> | crabapple varieties | | X | | S | X | Sparingly |
| <i>Cupressaceae</i> | <i>Metasquoia glytostoboides</i> | Dawn redwood | | X | | L | | Moderately |
| <i>Moraceae</i> | <i>Morus alba</i> | white mulberry | | X | | L | | Sparingly |
| <i>Moraceae</i> | <i>Morus rubra</i> | red mulberry | | X | X | M | | Frequently |
| <i>Nyssaceae</i> | <i>Nyssa sylvatica</i> | gum, black (tupelo) | X | X | X | M | | Frequently |
| <i>Betulaceae</i> | <i>Ostrya virginiana</i> | ironwood/ American hop-hornbeam | X | X | X | M | | Moderately |
| <i>Rutaceae</i> | <i>Phellodendron amurense</i> | amur corktree | | X | | M | | Moderately |
| <i>Pinaceae</i> | <i>Picea abies</i> | Norway spruce | | X | | L | | Frequently |

| Family Name | Botanical Name | Common Name | STREETS | PARKS or Large Street Treelawn | SWMP or other Naturalized area | SIZE | Hydro Approved (under) | Suggested Frequency of Planting |
|--------------------|--|----------------------------|---------|--------------------------------|--------------------------------|------|------------------------|---------------------------------|
| <i>Pinaceae</i> | <i>Picea glauca</i> | white spruce | | X | | L | | Frequently |
| <i>Pinaceae</i> | <i>Picea omorika</i> | Serbian spruce | | X | | L | | Frequently |
| <i>Pinaceae</i> | <i>Picea pungens</i> | Colorado spruce | | X | | L | | Sparingly |
| <i>Pinaceae</i> | <i>Pinus resinosa</i> | red pine | | X | | L | | Moderately |
| <i>Pinaceae</i> | <i>Pinus strobus</i> | white pine | | X | | L | | Frequently |
| <i>Platanaceae</i> | <i>Platanus x acerfolia</i> | planetree, London | X | X | | L | | Moderately |
| <i>Platanaceae</i> | <i>Platanus acerfolia 'bloodgood'</i> | Bloodgood London planetree | X | X | | L | | Sparingly |
| <i>Platanaceae</i> | <i>Platanus acerfolia 'morton circle'</i> | Exclamation planetree | X | | | L | | Sparingly |
| <i>Platanaceae</i> | <i>Platanus occidentalis</i> | American sycamore | | X | X | L | | Moderately |
| <i>Salicaceae</i> | <i>Populus Deltoides</i> | Eastern Cottonwood | | X | X | L | | Moderately |
| <i>Salicaceae</i> | <i>Populus balsamia</i> | balsam poplar | | X | X | L | | Moderately |
| <i>Salicaceae</i> | <i>Populus canadensis 'Eugenie'</i> | Carolina Poplar | | X | | L | | Moderately |
| <i>Salicaceae</i> | <i>Populus grandidentata</i> | Big Toothed Aspen | | X | X | L | | Moderately |
| <i>Salicaceae</i> | <i>Populus spp.</i> | poplar | | X | | L | | Moderately |
| <i>Salicaceae</i> | <i>Populus tremuloides</i> | trembling aspen | | X | X | L | | Moderately |
| <i>Rosaceae</i> | <i>Prunus cerasifera 'newport'</i> | Newport Flowering Plum | | x | | S | | Moderately |
| <i>Rosaceae</i> | <i>Prunus sargentii 'Rancho'</i> | Sargent Cherry | X | x | | S | | Moderately |
| <i>Rosaceae</i> | <i>Prunus serotina</i> | black cherry | | X | X | L | | Frequently |
| <i>Rosaceae</i> | <i>Prunus Serrulata 'Kwanzan'</i> | Flowering Japanese Cherry | | X | | S | | Sparingly |
| <i>Rosaceae</i> | <i>Prunes x yedoensis</i> | Yoshino cherry | | X | | S | | Sparingly |
| <i>Rosaceae</i> | <i>Prunus spp.</i> | ornamental cherry | | X | | S | | Sparingly |
| <i>Rosaceae</i> | <i>Prunus maackii</i> | Manchurian cherry | | X | | M | | Moderately |
| <i>Rosaceae</i> | <i>Prunus virginiana</i> | Chokecherry | X | X | | S | | Sparingly |
| <i>Rosaceae</i> | <i>Prunus virginiana 'Shubert'</i> | Shubert Chokecherry | X | X | | S | X | Sparingly |
| <i>Pinaceae</i> | <i>Pseudotsuga menziesii</i> | douglas fir | | X | | L | | Moderately |
| <i>Rosaceae</i> | <i>Pyrus calleryana 'Chanticleer'</i> | pear, Chanticleer | X | | | M | | Frequently |
| <i>Rosaceae</i> | <i>Pyrus calleryana 'Cleveland select'</i> | Cleveland Select Pear | X | | | S | | Frequently |
| <i>Rosaceae</i> | <i>Pyrus Fauriei 'Westwood'</i> | Korean Sun Pear | X | | | S | | Frequently |

| Family Name | Botanical Name | Common Name | STREETS | PARKS or Large Street Treelawn | SWMP or other Naturalized area | SIZE | Hydro Approved (under) | Suggested Frequency of Planting |
|--------------|---|-----------------------------|---------|--------------------------------|--------------------------------|------|------------------------|---------------------------------|
| Rosaceae | <i>Pyrus urssuriensis</i> 'Mordak' | Prairie Gem Ornamental Pear | X | | | S | | Frequently |
| Fagaceae | <i>Quercus alba</i> | white oak | | X | X | L | | Frequently |
| Fagaceae | <i>Quercus bicolor</i> | Swamp White Oak | X | X | X | M | | Frequently |
| Fagaceae | <i>Quercus coccinea</i> | Scarlet Oak | | X | | M | | Frequently |
| Fagaceae | <i>Quercus ellipsoidalis</i> | northern pin oak | | X | | L | | Frequently |
| Fagaceae | <i>Quercus inbricaria</i> | Shingle Oak | | X | | L | | Frequently |
| Fagaceae | <i>Quercus macrocarpa</i> | oak, bur | X | X | X | L | | Frequently |
| Fagaceae | <i>Quercus muehlenbergii</i> | Chinkapin Oak | X | X | X | M | | Frequently |
| Fagaceae | <i>Quercus palustris</i> | pin oak | | X | X | L | | Frequently |
| Fagaceae | <i>Quercus robur</i> | English Oak | | X | | L | | Frequently |
| Fagaceae | <i>Quercus robur</i> 'fastigiata' | pyramidal English oak | | | | L | | Frequently |
| Fagaceae | <i>Quercus rubra</i> | oak, red | X | X | X | L | | Sparingly |
| Fagaceae | <i>Quercus velutina</i> | black oak | | X | | L | | Frequently |
| Fabaceae | <i>Robinia pseudoacacia</i> | black locust | X | | | L | | Sparingly |
| Fabaceae | <i>Robinia pseudoacacia</i> 'PURPLE ROBE' | black locust 'Purple robe ' | X | | | M | | Sparingly |
| Salicaceae | <i>Salix alba tristis</i> | Golden Weeping Willow | | X | | L | | Sparingly |
| Salicaceae | <i>Salix bebbiana</i> | Bebb's willow | | X | | M | | Sparingly |
| Salicaceae | <i>Salix caprea pendula</i> | Weeping Pussy Willow | | X | | S | X | Sparingly |
| Salicaceae | <i>Salix nigra</i> | black willow | | X | X | M | | Sparingly |
| Lauraceae | <i>Sassafras albidum</i> | sassafras | | X | X | L | | Moderately |
| Fabaceae | <i>Sophora japonica</i> 'Regent' (<i>Styphnolobium japonicum</i>) | Japanese Pagoda Tree | | X | | L | | Moderately |
| Rosaceae | <i>Sorbus aucuparia</i> | mountain ash | X | X | | M | | Frequently |
| Rosaceae | <i>Sorbus thuringiaca</i> 'Fastigiata' | oakleaf mountain ash | X | X | | S | | Frequently |
| Oleaceae | <i>Syringa reticulata</i> | Japanese Tree Lilac | X | | | S | X | Frequently |
| Oleaceae | <i>Syringa reticulata</i> 'Ivory Silk' | lilac, Ivory silk | X | | | S | X | Frequently |
| Cupressaceae | <i>Taxodium distichum</i> 'Shawnee Brave' | common bald cypress | | X | | L | | Frequently |

| Family Name | Botanical Name | Common Name | STREETS | PARKS or Large Street Treelawn | SWMP or other Naturalized area | SIZE | Hydro Approved (under) | Suggested Frequency of Planting |
|-----------------------|--|---------------------------|---------|--------------------------------|--------------------------------|------|------------------------|---------------------------------|
| <i>Taxaceae</i> | <i>Taxus spp.</i> | yew spp. | | X | | S | X | Moderately |
| <i>Cupressaceae</i> | <i>Thuja occidentalis</i> | white cedar | | X | | M | | Frequently |
| <i>Tiliaceae</i> | <i>Tilia americana</i> | basswood | | X | X | L | | Frequently |
| <i>Tiliaceae</i> | <i>Tilia Americana 'continental appeal'</i> | Continental Appeal Linden | X | | | M | | Moderately |
| <i>Tiliaceae</i> | <i>Tilia americana 'lincoln'</i> | Lincoln Linden | X | | | L | | Moderately |
| <i>Tiliaceae</i> | <i>Tilia americana 'Redmond'</i> | linden, Redmond | X | | | L | | Moderately |
| <i>Tiliaceae</i> | <i>tilia cordata 'baileyi'</i> | Shamrock Linden | X | | | M | | Moderately |
| <i>Tiliaceae</i> | <i>Tilia cordata 'corzam'</i> | Corinthian Linden | X | | | M | | Moderately |
| <i>Tiliaceae</i> | <i>Tilia cordata</i> | little leaf linden | X | | | L | | Moderately |
| <i>Tiliaceae</i> | <i>Tilia cordata 'Greenspire'</i> | little leaf linden | X | | | L | | Moderately |
| <i>Tiliaceae</i> | <i>Tilia cordata 'halka'</i> | Summer Sprite Linden | X | | | S | | Moderately |
| <i>Tiliaceae</i> | <i>Tilia cordata x mongolica 'harvest gold'</i> | Harvest Gold Linden | X | | | M | | Moderately |
| <i>Tiliaceae</i> | <i>Tilia flavescens 'glenleven'</i> | Glenleven Linden | X | | | M | | Moderately |
| <i>Tiliaceae</i> | <i>Tilia tomentosa 'green mountain'</i> | Green Mountain Linden | X | | | M | | Moderately |
| <i>Tiliaceae</i> | <i>Tilia tomentosa 'sterling'</i> | Sterling Silver Linden | X | | | M | | Moderately |
| <i>Pinaceae</i> | <i>Tsuga canadensis</i> | hemlock | | X | | L | | Sparingly |
| <i>Ulmaceae</i> | <i>Ulmus davidiana var. japonica 'Accolade®'</i> | elm, Accolade | X | X | | L | | Frequently |
| <i>Ulmaceae</i> | <i>Ulmus americana 'valley forge'</i> | Valley Forge Elm | X | X | | L | | Frequently |
| <i>Ulmaceae</i> | <i>Ulmus 'Frontier'</i> | Frontier Elm | X | | | M | | Frequently |
| <i>Ulmaceae</i> | <i>Ulmus x 'Homestead'</i> | Homestead elm | X | | | L | | Frequently |
| <i>Ulmaceae</i> | <i>Ulmus japonica x pumila 'new horizon'</i> | New Horizon Elm | X | | | L | | Frequently |
| <i>Ulmaceae</i> | <i>Ulmus 'morton glossy'</i> | Triumph Elm | X | | | L | | Frequently |
| <i>Ulmaceae</i> | <i>Ulmus parvifolia</i> | Lacebark elm | X | X | | M | | Frequently |
| <i>Ulmaceae</i> | <i>Ulmus 'Princeton'</i> | Princeton elm | X | X | | L | | Frequently |
| <i>Ulmaceae</i> | <i>Ulmus propinqua 'emerald sunshine'</i> | Emerald Sunshine Elm | X | X | | M | | Frequently |
| <i>Ulmaceae</i> | <i>Ulmus wilsoniana 'prospector'</i> | Prospector Elm | X | X | | L | | Frequently |
| <i>Caprifoliaceae</i> | <i>Viburnum lentago (Std.)</i> | nannyberry (tree form) | | X | X | S | X | Sparingly |

| Family Name | Botanical Name | Common Name | STREETS | PARKS or Large Street Treelawn | SWMP or other Naturalized area | SIZE | Hydro Approved (under) | Suggested Frequency of Planting |
|-----------------|---|--------------------------|---------|--------------------------------|--------------------------------|------|------------------------|---------------------------------|
| <i>Ulmaceae</i> | <i>Zelkova serrata</i> | zelkova, Japanese | X | | | L | | Moderately |
| <i>Ulmaceae</i> | <i>Zelkova serrata</i> 'green vase' | Green vase Zelkova | X | | | M | | Moderately |
| <i>Ulmaceae</i> | <i>Zelkova serrata</i> 'village green' | Village Green Zelkova | X | | | M | | Moderately |

Appendix D: Minimum Offsets for Streetlights



Appendix A – Minimum Offset for Street lighting

| ABOVE GROUND STRUCTURE | SEPARATION FROM STREELIGHTS |
|---|-----------------------------|
| Fire Hydrant | 3.0 m |
| Valves and Curb Stops | 1.0 m |
| Driveway | 1.5 m |
| Sidewalk | 1.0 m |
| Hydro Transformer | 3.0 m |
| Telecommunications Pedestals | 1.0 m |
| Community Mailbox Pad | 3.0 m |
| Catch basin and Maintenance hole structures | 1.0 m |
| Trees | 4.5 m |

Appendix E: Cost Estimate Template



PROJECT NAME
CONSTRUCTION COST ESTIMATE - INTERNAL WORKS/EXTERNAL WORKS
PROJECT FILE #
DATE

| ITEM NO. | DESCRIPTION | UNIT | ESTIMATED QUANTITY | UNIT PRICE | TOTAL ESTIMATE | VALUE OF WORK COMPLETE | VALUE OF WORK OUTSTANDING |
|---|------------------------|----------------|--------------------|------------|----------------|------------------------|---------------------------|
| 1.0 REMOVALS | | | | | | | |
| 1.01 | Removal Item 1 | ea | | \$ - | \$ - | \$ - | \$ - |
| 1.02 | Removal Item 2 | m | | \$ - | \$ - | \$ - | \$ - |
| 1.03 | Removal Item 3 | m2 | | \$ - | \$ - | \$ - | \$ - |
| 1.04 | Removal Item 4 | m2 | | \$ - | \$ - | \$ - | \$ - |
| 1.05 | Removal Item 5 | m2 | | \$ - | \$ - | \$ - | \$ - |
| 1.06 | Removal Item 6 | m2 | | \$ - | \$ - | \$ - | \$ - |
| SUBTOTAL REMOVALS | | | | | \$ - | \$ - | \$ - |
| SECURITIES REQUIRED | | | | | 0% \$ - | | \$ - |
| 2.0 SILTATION AND EROSION CONTROL | | | | | | | |
| 2.01 | Erosion Control Item 1 | m | | \$ - | \$ - | \$ - | \$ - |
| 2.02 | Erosion Control Item 2 | ea. | | \$ - | \$ - | \$ - | \$ - |
| 2.03 | Erosion Control Item 3 | ea. | | \$ - | \$ - | \$ - | \$ - |
| SUBTOTAL SILTATION AND EROSION CONTROL | | | | | \$ - | \$ - | \$ - |
| SECURITIES REQUIRED | | | | | 0% \$ - | | \$ - |
| 3.0 SANITARY | | | | | | | |
| 3.01 | Sanitary Item 1 | m | | \$ - | \$ - | \$ - | \$ - |
| 3.02 | Sanitary Item 2 | ea. | | \$ - | \$ - | \$ - | \$ - |
| 3.03 | Sanitary Item 2 | ea. | | \$ - | \$ - | \$ - | \$ - |
| 3.04 | Sanitary Item 4 | ea. | | \$ - | \$ - | \$ - | \$ - |
| SUBTOTAL SANITARY | | | | | \$ - | \$ - | \$ - |
| SECURITIES REQUIRED | | | | | 0% \$ - | | \$ - |
| 4.0 STORM | | | | | | | |
| 4.01 | Storm Item 1 | m | 0.0 | \$ - | \$ - | \$ - | \$ - |
| 4.02 | Storm Item 2 | ea. | 0 | \$ - | \$ - | \$ - | \$ - |
| 4.03 | Storm Item 3 | ea. | 0 | \$ - | \$ - | \$ - | \$ - |
| 4.04 | Storm Item 4 | L.S | 0 | \$ - | \$ - | \$ - | \$ - |
| 4.05 | Storm Item 5 | ea. | 0 | \$ - | \$ - | \$ - | \$ - |
| 4.06 | Storm Item 6 | L.S | 0 | \$ - | \$ - | \$ - | \$ - |
| 4.07 | Storm Item 7 | m | 0 | \$ - | \$ - | \$ - | \$ - |
| SUBTOTAL STORM | | | | | \$ - | \$ - | \$ - |
| SECURITIES REQUIRED | | | | | 0% \$ - | | \$ - |
| 5.0 WATERMAIN WORKS | | | | | | | |
| 5.01 | Watermain Item 1 | L.S | 0 | \$ - | \$ - | \$ - | \$ - |
| 5.02 | Watermain Item 2 | m ² | 0 | \$ - | \$ - | \$ - | \$ - |
| 5.03 | Watermain Item 3 | m ² | 0 | \$ - | \$ - | \$ - | \$ - |
| 5.04 | Watermain Item 4 | m ² | 0 | \$ - | \$ - | \$ - | \$ - |
| 5.05 | Watermain Item 5 | m ² | 0 | \$ - | \$ - | \$ - | \$ - |
| 5.06 | Watermain Item 6 | m | 0 | \$ - | \$ - | \$ - | \$ - |
| 5.07 | Watermain Item 7 | m | 0 | \$ - | \$ - | \$ - | \$ - |
| 5.08 | Watermain Item 8 | m ² | 0 | \$ - | \$ - | \$ - | \$ - |
| 5.09 | Watermain Item 9 | L.S | 0 | \$ - | \$ - | \$ - | \$ - |
| SUBTOTAL WATERMAIN | | | | | \$ - | \$ - | \$ - |
| SECURITIES REQUIRED | | | | | 0% \$ - | | \$ - |
| 6.0 ROAD WORKS | | | | | | | |
| 6.01 | Road Works Item 1 | L.S | 0 | \$ - | \$ - | \$ - | \$ - |
| 6.02 | Road Works Item 2 | m ² | 0 | \$ - | \$ - | \$ - | \$ - |
| 6.03 | Road Works Item 3 | m ² | 0 | \$ - | \$ - | \$ - | \$ - |
| 6.04 | Road Works Item 4 | m ² | 0 | \$ - | \$ - | \$ - | \$ - |
| 6.05 | Road Works Item 5 | m ² | 0 | \$ - | \$ - | \$ - | \$ - |
| 6.06 | Road Works Item 6 | m | 0 | \$ - | \$ - | \$ - | \$ - |
| 6.07 | Road Works Item 7 | m | 0 | \$ - | \$ - | \$ - | \$ - |
| 6.08 | Road Works Item 8 | m ² | 0 | \$ - | \$ - | \$ - | \$ - |
| 6.09 | Road Works Item 8 | m ² | 0 | \$ - | \$ - | \$ - | \$ - |
| SUBTOTAL ROAD | | | | | \$ - | \$ - | \$ - |
| SECURITIES REQUIRED | | | | | 0% \$ - | | \$ - |
| 7.0 MISCELLANEOUS | | | | | | | |
| 7.01 | Misc. Item 1 | m | 0.0 | \$ - | \$ - | \$ - | \$ - |
| 7.02 | Misc. Item 2 | ea | 0 | \$ - | \$ - | \$ - | \$ - |
| SUBTOTAL MISCELLANEOUS | | | | | \$ - | \$ - | \$ - |
| SECURITIES REQUIRED | | | | | 0% \$ - | | \$ - |
| SUBTOTAL SECTIONS 1-7 | | | | | \$ - | \$ - | \$ - |
| SECURITIES REQUIRED | | | | | \$ - | | \$ - |
| ENGINEERING AND CONTINGENCY (15%) | | | | | \$ - | \$ - | \$ - |
| ENGINEERING AND CONTINGENCY SECURITY (15%) | | | | | \$ - | | \$ - |
| HST (13%) | | | | | \$ - | \$ - | \$ - |
| HST ON SECURITY (13%) | | | | | \$ - | | \$ - |
| TOTAL (Incl. HST) | | | | | \$ - | \$ - | \$ - |
| TOTAL SECURITY REQUIRED | | | | | \$ - | | \$ - |

Excludes:

- Exclusion Item 1
- Exclusion Item 2
- Exclusion Item 3
- Exclusion Item 4
- Exclusion Item 5
- Exclusion Item 6
- Exclusion Item 7
- HST